

First Reading: August 15, 2013
Second Reading: dispensed

RESOLUTION 2013 - 139

**A RESOLUTION APPROVING A CHANGE ORDER TO A CONTRACT FOR THE
KENWOOD ROAD UTILITY AND ROADWAY IMPROVEMENTS PROJECT,
DISPENSING WITH THE SECOND READING AND DECLARING AN EMERGENCY**

WHEREAS, the Board of Township Trustees has contracted for improvements of roads and utilities on Kenwood Road in the Township (the "Kenwood Road Utility and Roadway Improvements Project"); and

WHEREAS, the Board of Township Trustees desires to approve a change order to the contract for the Kenwood Road Utility and Roadway Improvements Project;

NOW THEREFORE, BE IT RESOLVED by the Board of Township Trustees of Sycamore Township, State of Ohio:

SECTION 1. The attached change orders to the contract with Bansal Construction for the Kenwood Road Utility and Roadway Improvements Project in the amount of \$11,544.00 is hereby approved and the Assistant Township Administrator or the Road Superintendent are authorized and directed to execute the change order on behalf of the Board.

SECTION 2. The Board of Township Trustees of Sycamore Township, by at least two-third vote of all of its members, dispenses with the requirement that this Resolution be read on two separate days and authorizes its passage upon one reading.

SECTION 3. This Resolution is hereby declared to be an emergency measure, necessary for the preservation of the public peace, health, welfare, and safety of the Sycamore Township. The reason for the emergency is to provide for the immediate and continuing improvements to safety of the roads in the Township.

VOTE RECORD:

Mr. Bishop Aye Mr. Connor Aye Mr. Weidman Aye

PASSED at a meeting of the Board of Township Trustees this 15th day of August, 2013.

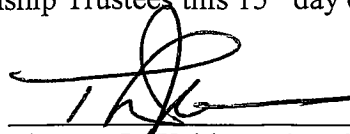

Thomas J. Weidman, President

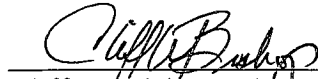

Cliff W. Bishop, Vice President

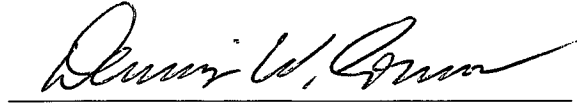

Dennis W. Connor, Trustee

AUTHENTICATION

This is to certify that this Resolution was duly passed and filed with the Sycamore Township Fiscal Officer, this 15th day of August, 2013.

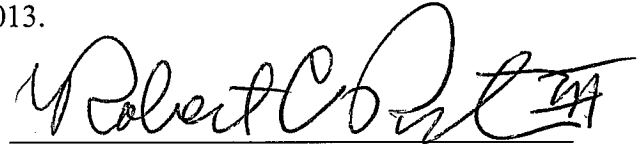

Robert C. Porter, III
Sycamore Township Fiscal Officer

APPROVED AS TO FORM:



R. Douglas Miller, Law Director

Overall Summary

Month: _____ Construc. Days

Project No.: KENWOOD DSR: _____ 000

Co./Rt./Sec.: UTILITIES IMPROVEMENTS Contractor: BANSAL CONSTRUCTION, INC.

Change Order No.: CO2013004E

Created by: ALAY BANSAL

LABOR MONTHLY COST SUMMARY

WORK: INSTALL PULL BOXES IN BURGER KING DRIVEWAY

Labor Cost...see sheet 2

THE DUCT RUN AS SPECIFIED ENCOUNTERED

Fringes... see sheet 2 + _____

RETAINING WALL FOUNDATIONS & THE

Subtotal

DUMPS TER. ONE EACH PULL BOX WILL BE NEEDED

Profit and Overhead +

DUKE, CINCINNATI BELL AND TIME WARNER.

Administration Fees... see sheet 2 +

THE PULL BOXES NEED TO BE TRAFFIC BEARING PER ATTCHED

Pay Roll Tax...34.55% + _____

SUGGESTED DETAIL. THIS COST WILL BE

Total Labor Cost

IN ADDITION TO REMOVAL OF THE DUMPS TER RELATED COSTS

TO BUILD THE DUCT RUN.

MONTHLY FORCE ACCOUNT SUMMARY

NOTES: THE COST IS BASED ON CONTRACT UNIT PRICES

Total Labor Cost

Total Owned Equipment Cost

Total Rented Equipment Cost

Total Material Cost

Contract Unit Bid Price \$11,544.00

Subcontractor Price

Total Monthly FA Cost \$11,544.00

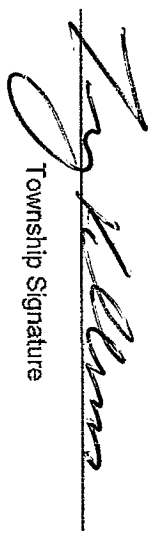
Township Signature

Date

8/15/13

Contractor Signature

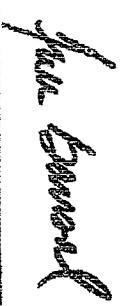

Date

7/25/2013

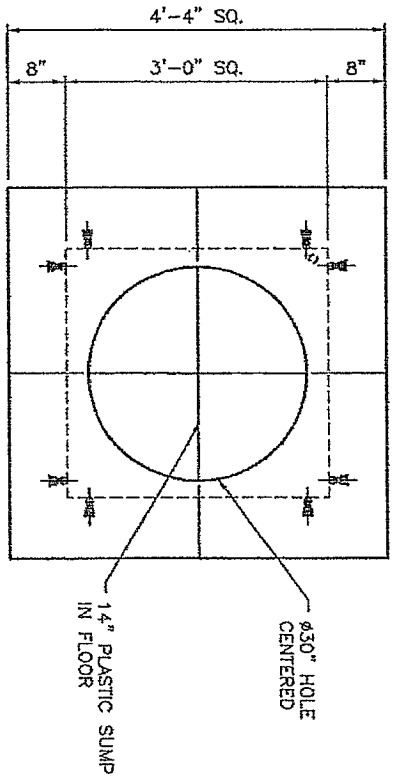

PLAN VIEW
SCALE: 1/2" = 1'-0"

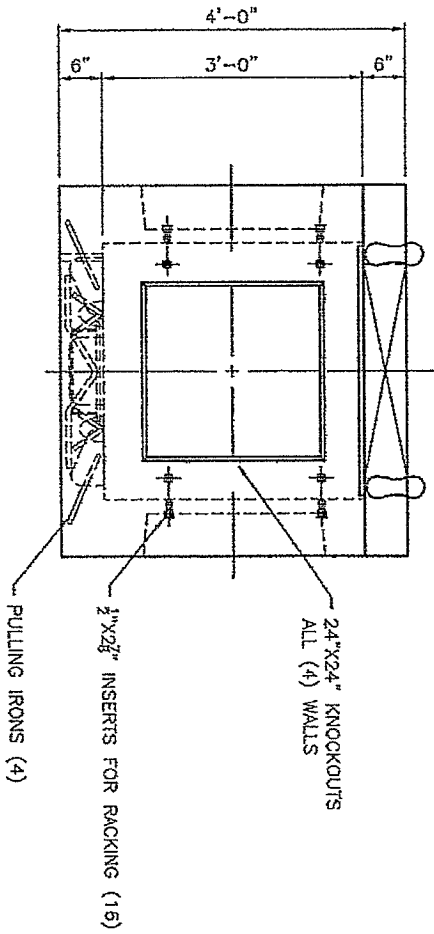

VIEW A
SCALE: 1/2" = 1'-0"
3 REQUIRED

- GENERAL NOTES:
1. CONCRETE: 28 DAY COMPRESSIVE STRENGTH F_C = 6,000 PSI
 2. STEEL REINFORCEMENT: ASTM A-615, GRADE 80
 3. COVER TO STEEL-1" MINIMUM
 4. DESIGNED TO MEET ACI 318 FOR: HS 20 LIVE LOAD 45 PCF SOIL EFB 0'-0" SOIL COVER WATER TABLE 3'-0" BELOW GRADE JOINT SEALANT: CONSUAL BUTYL SEALANT ASTM C-990-91
 5. WEIGHT: 965 LBS
 6. TOP - BOTTOM - 6278 LBS

HARDWARE PACKAGE	
QUANTITY	DESCRIPTION
8	10d-11-18HOLE RACKS
16	1/2" X 2" - GALV. BOLTS
16	1/2" WASHERS, GALV.

CONTRACTOR IS TO VERIFY THAT ALL INFORMATION SHOWN ON DRAWINGS HAS BEEN THOROUGHLY CHECKED COMPLETELY AND CORRECTOR DOCUMENTS, APPROVES AND RESPONSIBILITY FOR INSTALLATION ERRORS BY THE CONTRACTOR AND ERRORS OR OMISSIONS RESULTING AFTER RECEIPT OF APPROVED SHOP DRAWINGS.

NOTE: PRODUCTION WILL NOT COMMENCE UNTIL RECEIPT OF SIGNED APPROVED SHOP DRAWINGS.

APPROVED
FOR PRODUCTION

BY: _____
DATE: _____



717 ALBANYE BLVD., LEBANON, NY 4910
PHONE: 516-255-1466 FAX: 516-255-1351

THIS DRAWING IS THE PROPERTY OF OLDCASTLE PRECAST, INC. IT IS LOANED TO THE ARCHITECT FOR HIS USE ONLY AND SHALL NOT BE USED IN ANY WAY WITHOUT THE WRITTEN PERMISSION OF OLDCASTLE PRECAST, INC. ALL RIGHTS RESERVED.

3' X 3' X 3' PULL BOX
SUBMITTAL
KENWOOD ROAD,
CINCINNATI, OHIO

DESIGNED BY: BANSAI CONSTRUCTION
DATE: 7/25/13
PH: KS
KS
KS

DATE	BY	REVISION	SHEET
7/25/13	PH	79307	OF 2
	KS		
	KS		
	KS		

3x3x3-PB-Top/Shop

3'-0" x 3'-0" x 3'-0" I.D. Pull Box

Model: 333 PB

File: 384UEP333PB-1DWG

ELECTRICAL

Oldcastle Precast



B30 or SB30
Weight: 650 or 580 Lbs

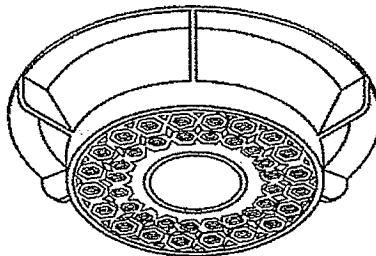

333 TOP SLAB
Weight: 610 Lbs

30" ϕ Opening

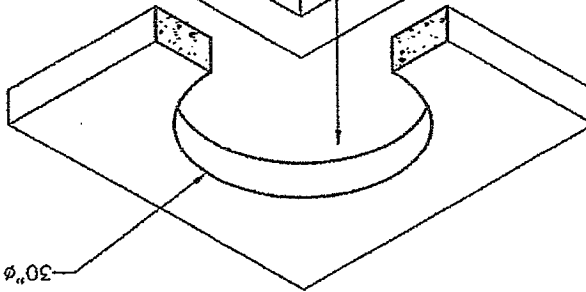

333 BASE
Weight: 3,900 Lbs

Opening for Ground Rod

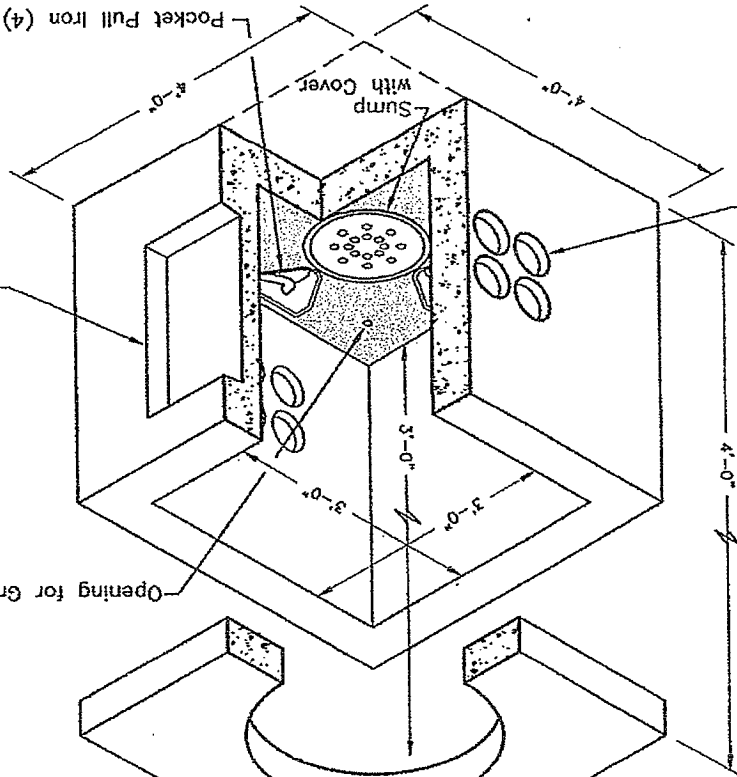

- GENERAL NOTES:**
1. Concrete: 28 day compressive strength $f_c = 4,500$ psi.
 2. Reinforcing: ASTM A-615, Grade 60.
 3. Joint Sealant: Butyl Rubber SS-S-00210.
 4. Designed for maximum soil cover of 5'-0" above box.
 5. Supports an H2O loading as indicated by AASHTO.

For more information about our products please visit us on the web at:

oldcastleprecast.com/lexington
© 2010 Oldcastle Precast, Inc.

747 Alenhdge Point
Lexington, KY 40510
Fax: (859) 233-9351

Oldcastle Precast
Lexington, KY Division
Phone: (859) 259-1484

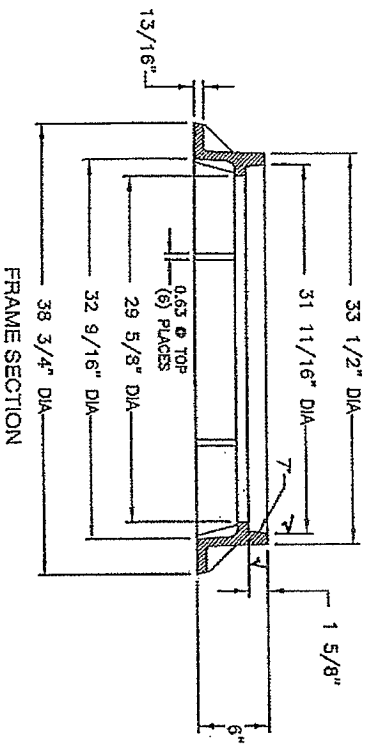
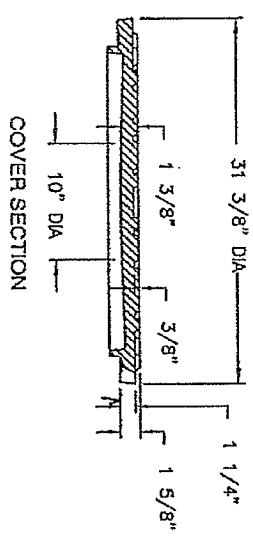
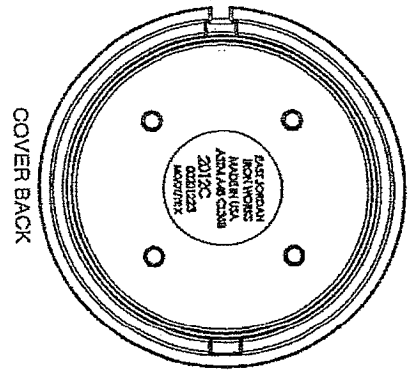
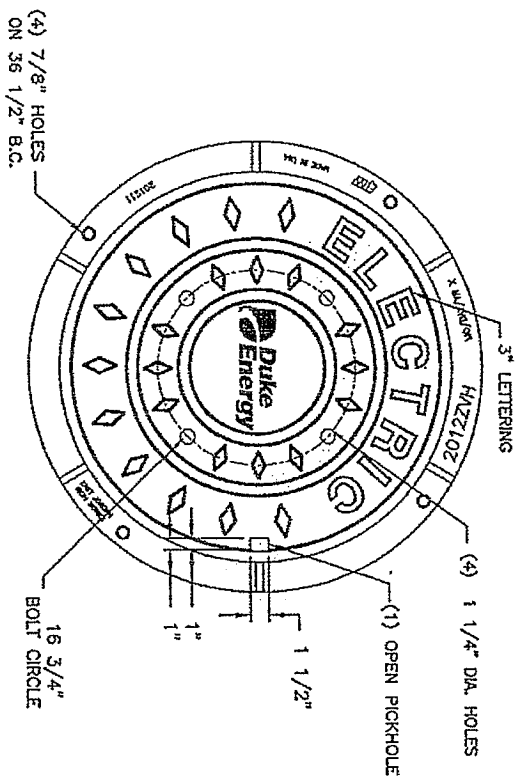

EJW EAST JORDAN
IRON WORKS EST. 1898

800-626-4653
www.ejw.com
MADE IN USA

PRODUCT NUMBER
00201201

CATALOG NUMBER
2012C
2012ZVH

MANHOLE
ASSEMBLY

LOAD RATING
HEAVY DUTY

COATING
UNDIPPED

ESTIMATED WEIGHT
COVER: 216 LBS
FRAME: 200 LBS
UNIT: 416 LBS

MATERIAL SPECIFICATION
COVER - GRAY IRON
ASTM A48 CL35B
FRAME - GRAY IRON
ASTM A48 CL35B

OPEN AREA
N/A

✓ DESIGNATES MACHINED SURFACE

DRAWN	DATE
DEW	09/07/06
LAST REVISED	DATE
DEW	04/19/08

REFERENCE INFORMATION
00201223
00201211

CONFIDENTIAL. This drawing is the property of East Jordan Iron Works, Inc. and embodies confidential information, trade secret information, and/or know how that is the property of East Jordan Iron Works, Inc. © Copyright 2006 East Jordan Iron Works, Inc.

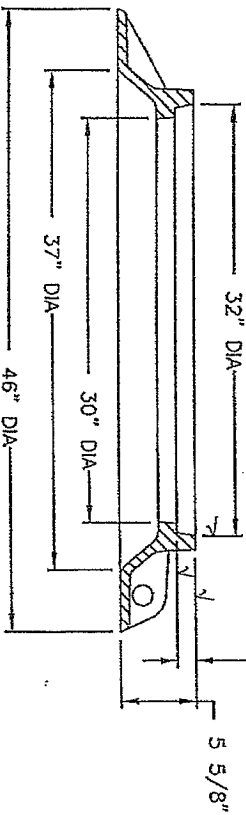
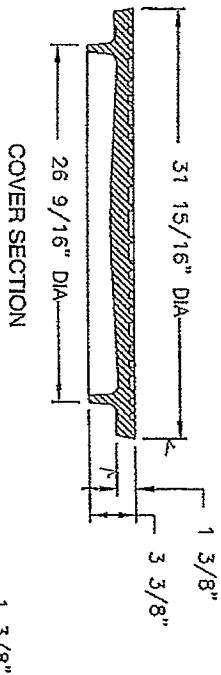
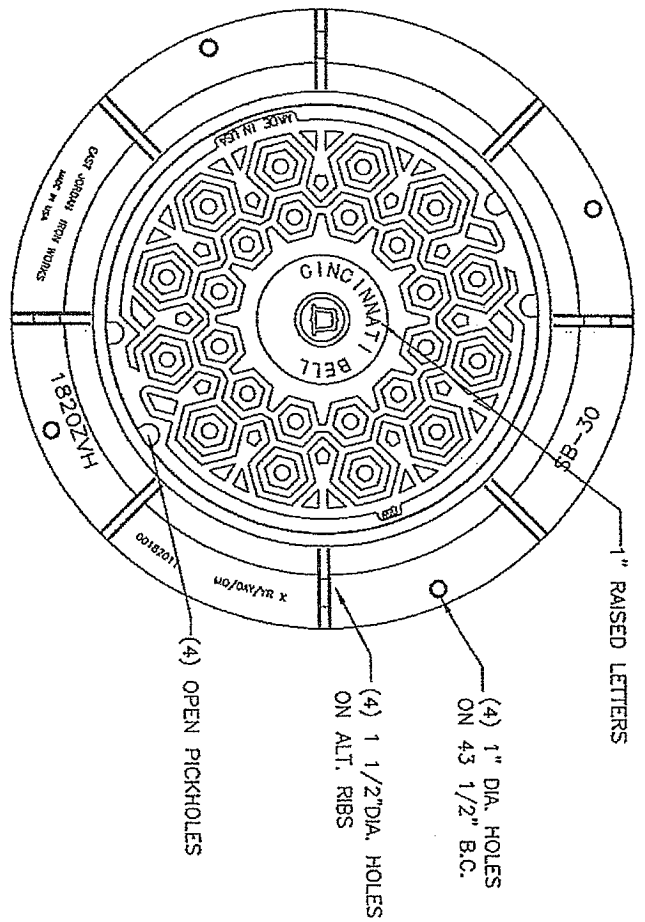

CONFIDENTIAL: This drawing is the property of East Jordan Iron Works, Inc. and embodies confidential information, trade secret information, and/or know how that is the property of East Jordan Iron Works, Inc. © Copyright 2007 East Jordan Iron Works, Inc.

EJW EAST JORDAN
IRON WORKS EST. 1983

800-626-4653
www.ejw.com
MADE IN USA

PRODUCT NUMBER
00182051

CATALOG NUMBER
1810A1VH
1820ZVH

MANHOLE
ASSEMBLY

LOAD RATING
HEAVY DUTY

COATING
UNDIPPED

MATERIAL SPECIFICATION
COVER - GRAY IRON
ASTM A48 CL35B
FRAME - GRAY IRON
ASTM A48 CL35B

OPEN AREA
N/A

DESIGNATES MACHINED SURFACE

DRAWN	DATE
SBB	01/02/04

LAST REVISED	DATE
GAD	01/08/09

REFERENCE INFORMATION
00180881
00182011

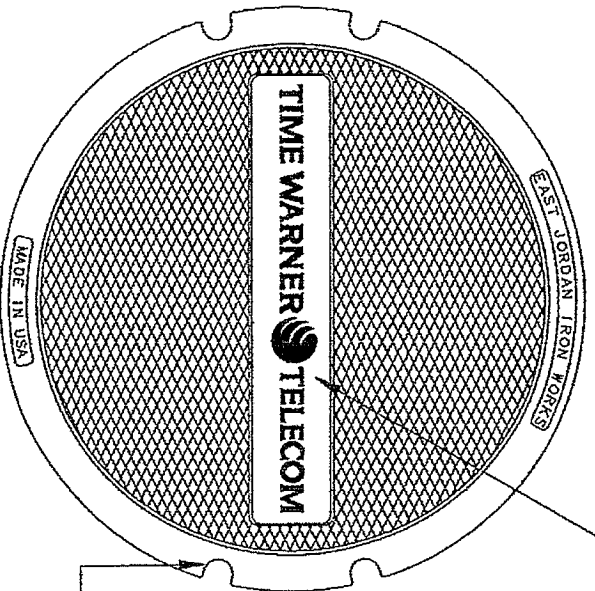

1 1/4" (32mm) LETTERS
(RECESSED FLUSH)

(4) OPEN PICKHOLES

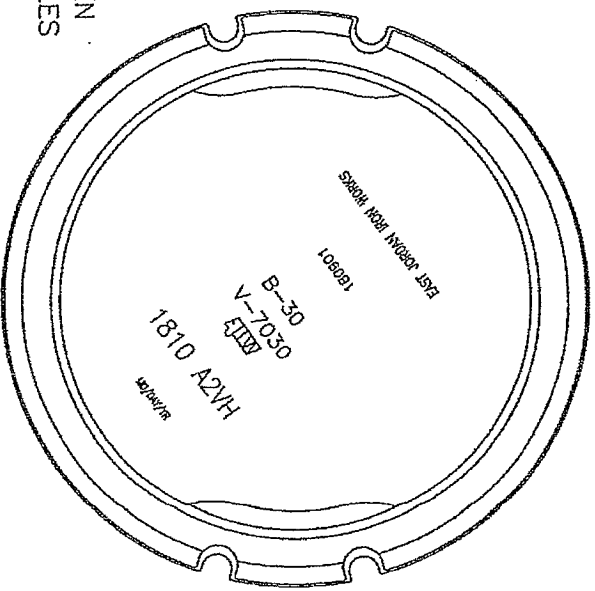

BOTTOM OF COVER

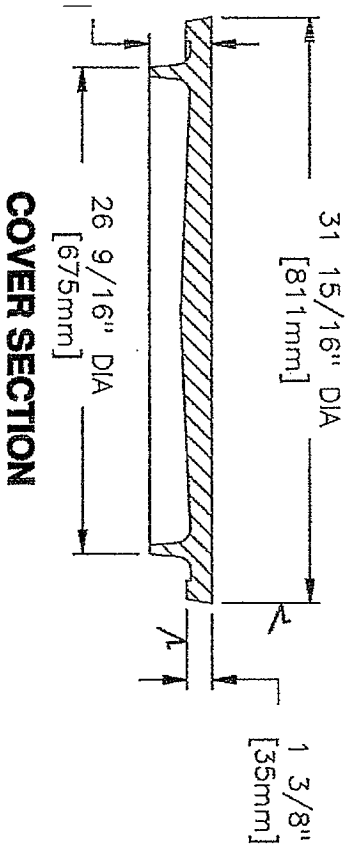

COVER SECTION

✓ MACHINED SURFACE

EAST JORDAN IRON WORKS, INC. P.O. BOX 439 EAST JORDAN, MI. 49727 1-800-874-4100 FAX 231-538-4458	
DRAWN J/J	DATE 04/04/01
APPROVED	DATE
MANHOLE COVER	
PRODUCT NO. 00180901	
CATALOG NO. 1810A2VH	
REF. PRODUCT DRAWING 181023	
EST. WT. COVER: 295 LBS 134kg	
OPEN AREA N/A	
MAT'L SPEC. COVER - GRAY IRON ASTM A48 CL35	
LOAD RATING HEAVY DUTY	

DAN S, INC. 139 49727 1100 -4458	
DATE /04/01	DATE
OVER	NO.
101	101
DRAWING VH	DRAWING VH
3	3
S 134kg	S 134kg
A	A
CL35	CL35
UTY	UTY

1820ZVH Frame

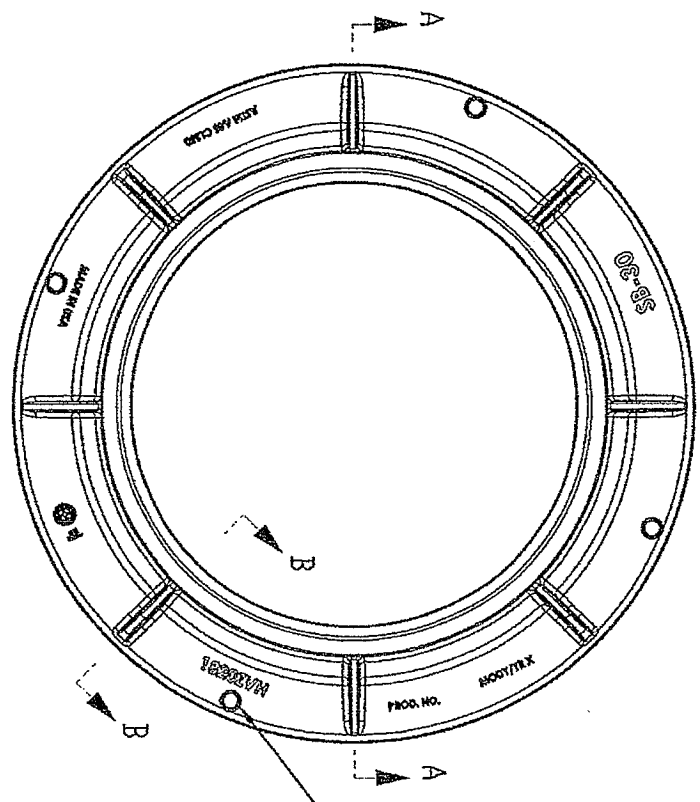

(4) 1" DIA. HOLES
ON 4 3/4" DIA
BOLT CIRCLE

Ø1 1/2 HOLES
(4) PLACES ON
ALT. RIBS

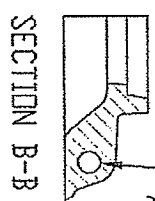

SECTION B-B

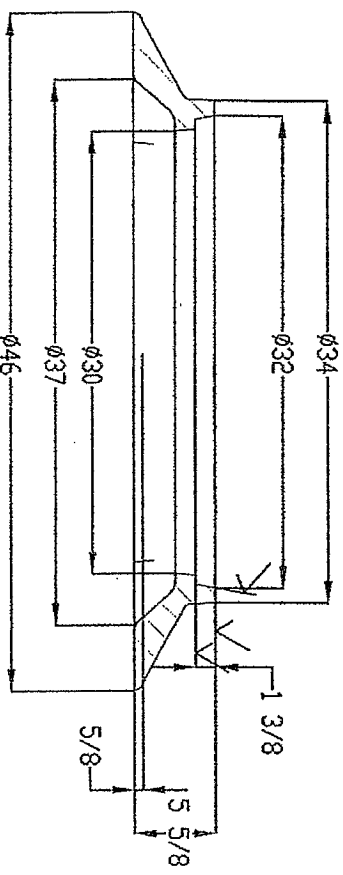

SECTION A-A

- Product Number: 00182011
- Design Features:
 - Materials: Gray Iron (CL35B)
 - Design Load: Heavy Duty
 - Open Area: N/A
 - Coating: Undipped
- Designates Machined Surface

Certification: -ASTM A48
Country of Origin: USA

Drawing Revision: 10/22/2007 Designer: SBB
8/13/2012 Revised By: SDC

Disclaimer
Weighs (the key dimensions (inch/mm)) and finishes provided for your guidance. We reserve the right to modify specifications without prior notice.
CONFIDENTIAL: This drawing is the property of EJ GROUP, Inc., and embodies confidential information, registered marks, patents, trade secret information, and/or know how that is the property of EJ GROUP, Inc. Copyright © 2012 EJ GROUP, Inc. All rights reserved.

Contact:
800 626 4653
ejco.com



UAPULLIRON
 FILE NAME: 386UAPULLIRON.DWG
 ISSUE DATE: June, 2001
 www.oldcastleprecast.com

Pull Iron

Copyright © 2001 Oldcastle Precast, Inc.

SCALE: 1-1/2" = 1'-0"

FRONT VIEW

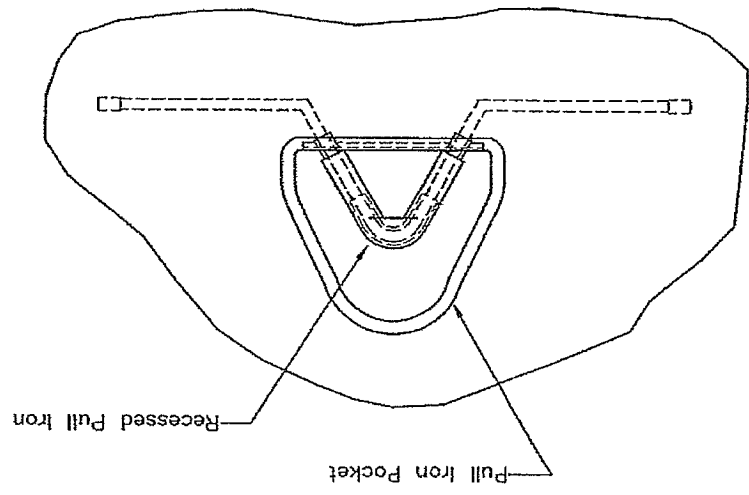

SIDE VIEW

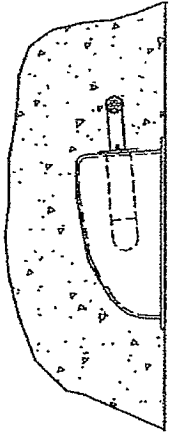

SIDE VIEW

Pulling Iron Must be Securely Attached to the Steel Reinforcement Cage as Depicted Above.

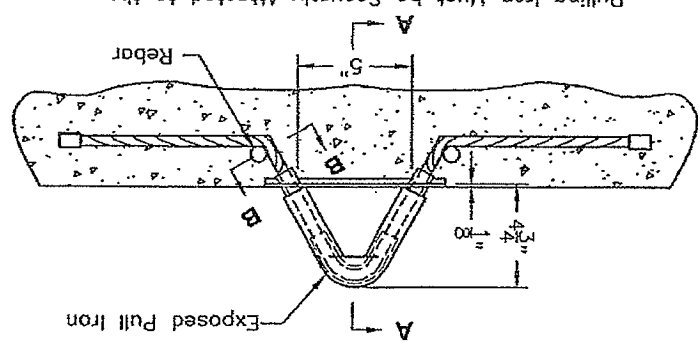

TOP VIEW

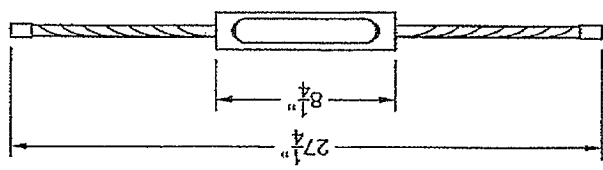

SECTION B-B

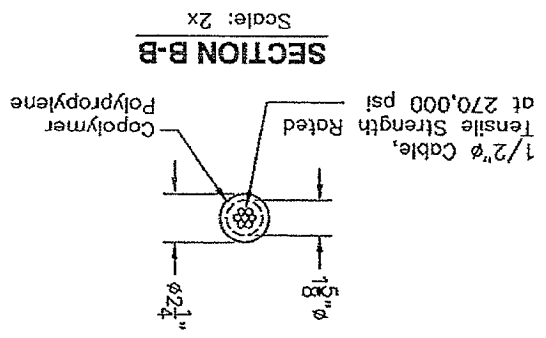

SECTION A-A

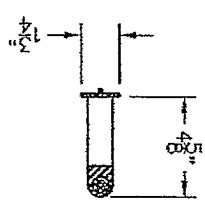

Standard Utility Vault
Sump Pan With Lid

Copyright © 2001 Oldcastle Precast, Inc.

www.oldcastleprecast.com

ISSUE DATE: February, 2002

FILE NAME: 384UASUMP.DWG

UASUMP



SCALE: 1/4" = 1"

Glass Filled Copolymer Polypropylene
Conforms to ASTM D-401

SUMP PAN

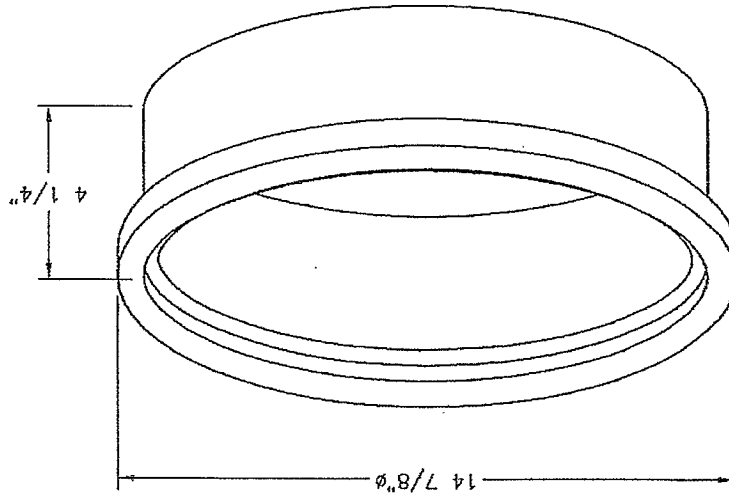

SUMP LID

