

3 TYP. TREE PLANTING DETAIL
SCALE: NOT TO SCALE

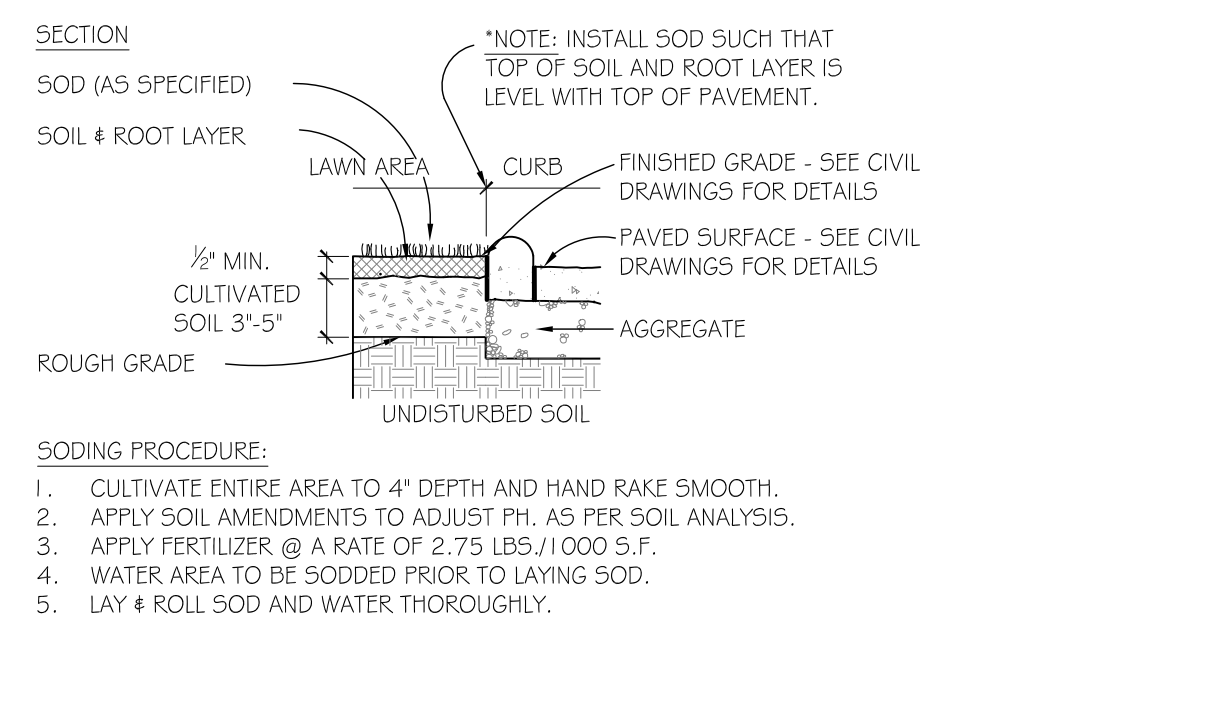

4 SOD-CURB INSTALLATION DETAIL
SCALE: NOT TO SCALE

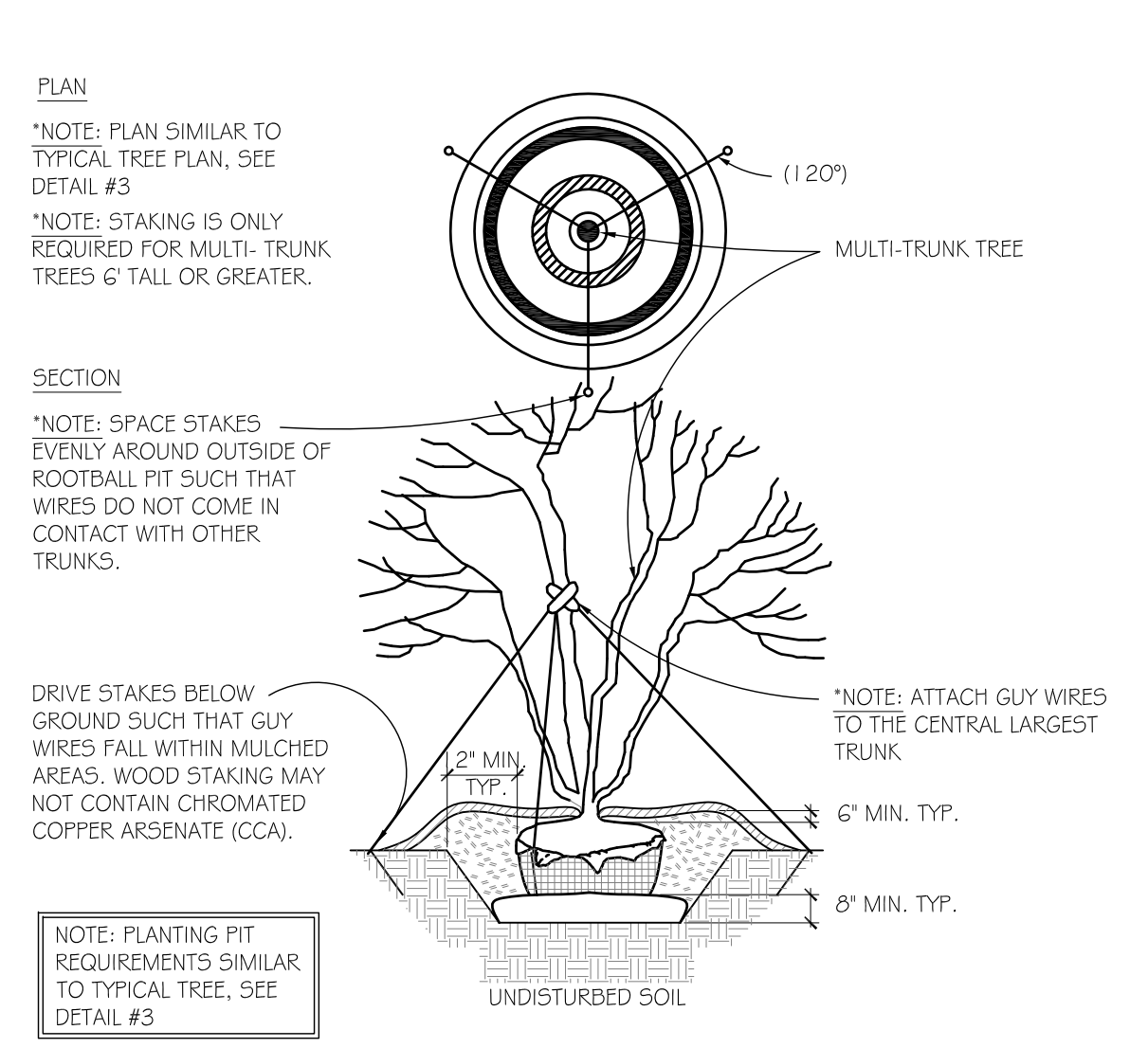

2 CLUMP TREE PLANTING DETAIL
SCALE: NOT TO SCALE

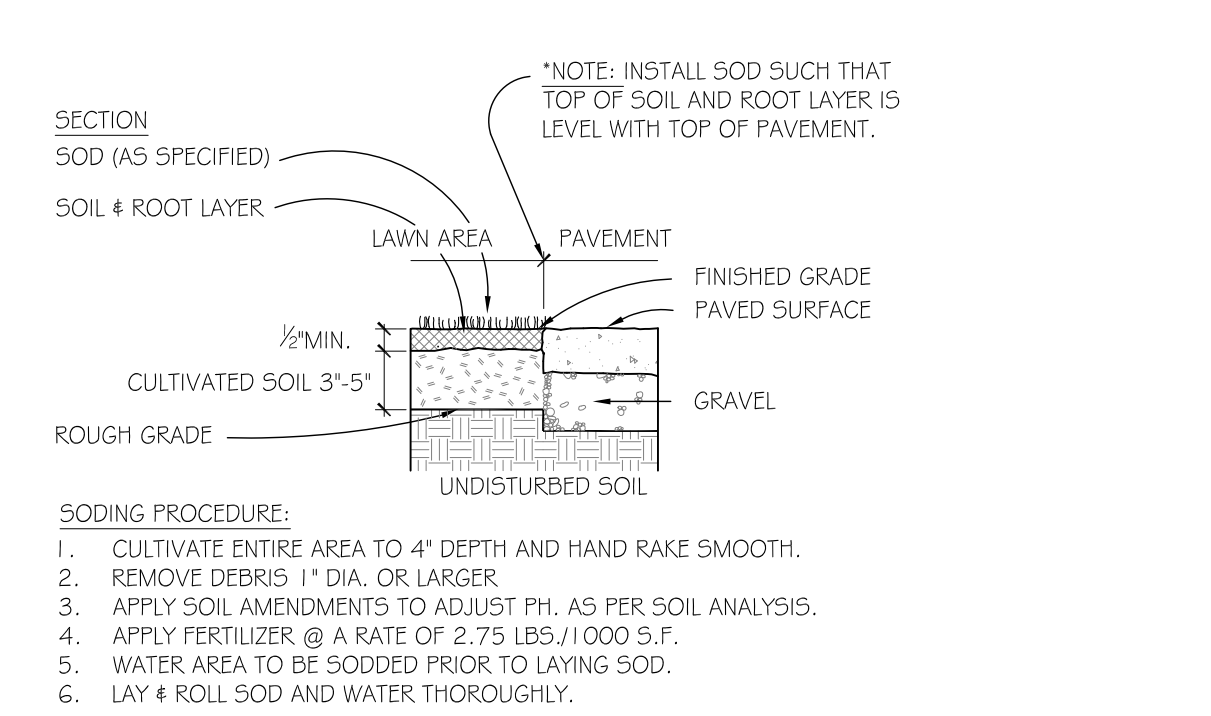

5 SODWALK INSTALLATION DETAIL
SCALE: NOT TO SCALE

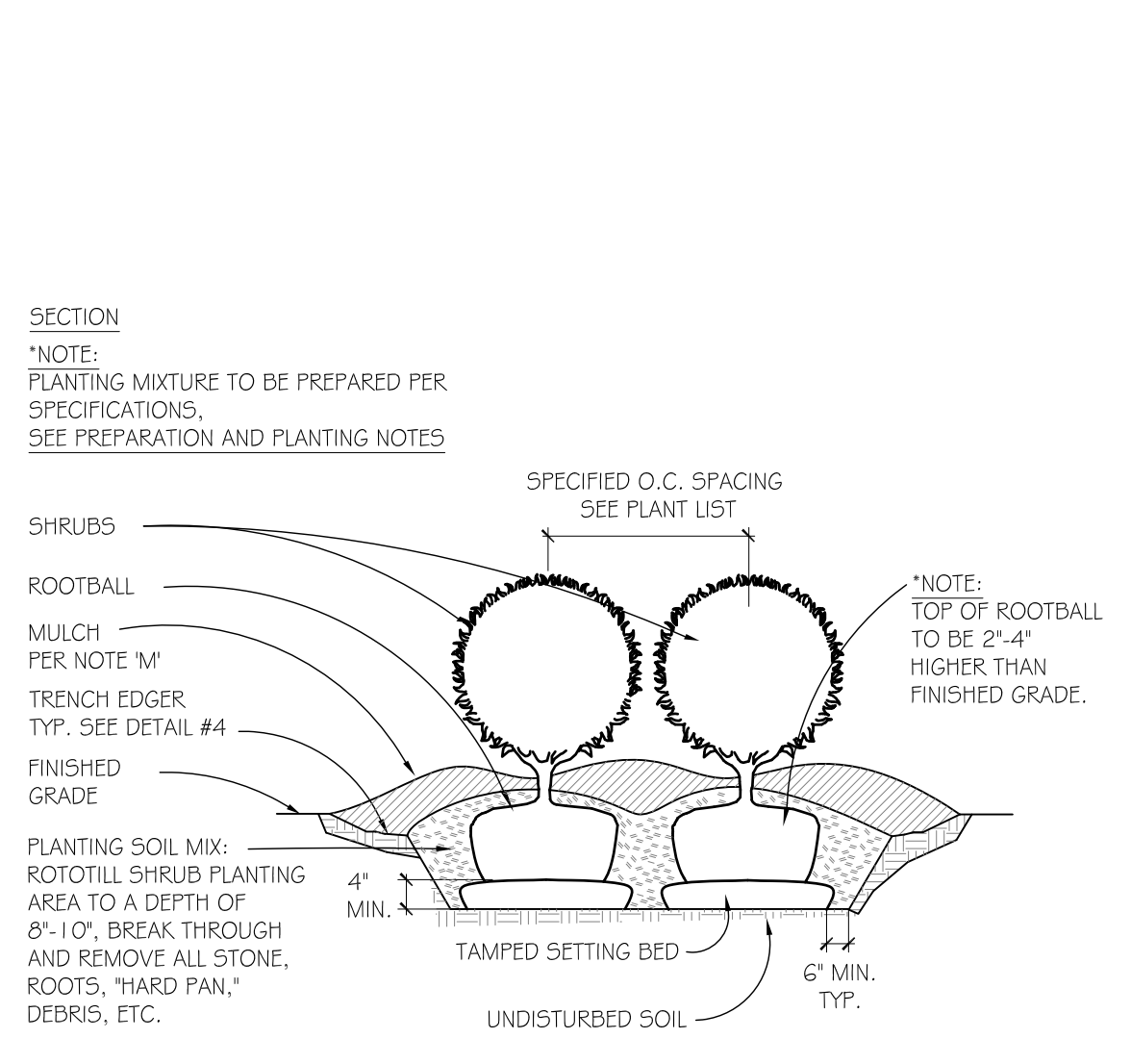

1 SHRUB BED PLANTING DETAIL
SCALE: NOT TO SCALE

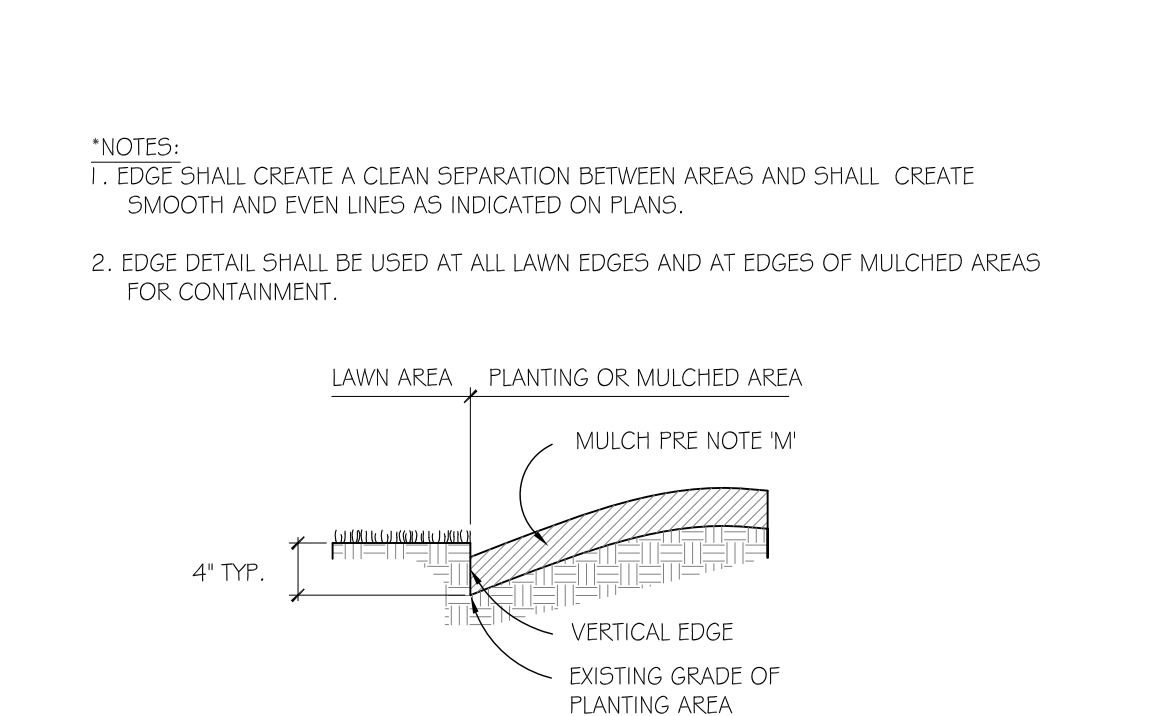

4 SHRUB BED EDGE DETAIL
SCALE: NOT TO SCALE

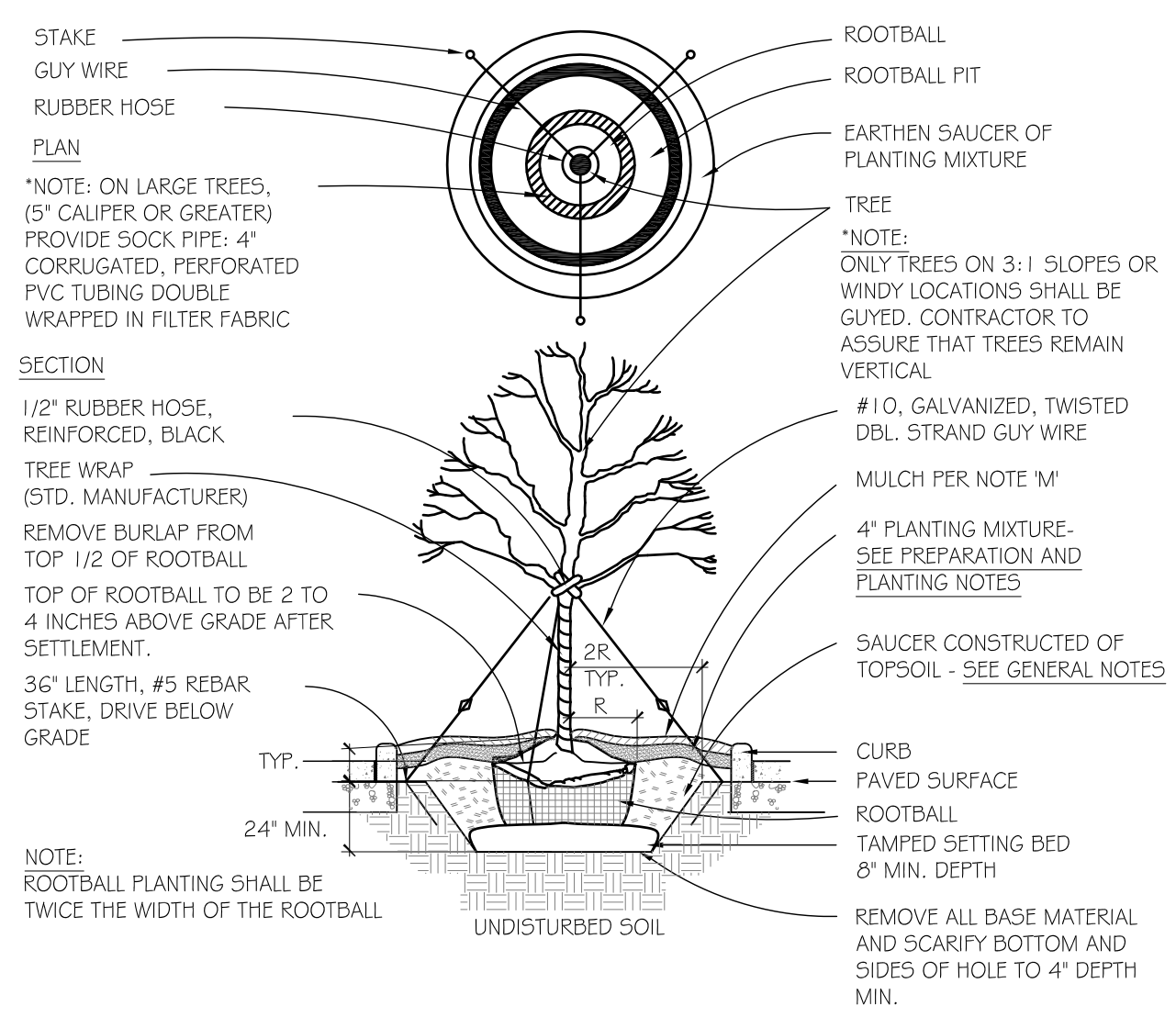

8 TYP. TREE ISLAND PLANTING DETAIL
SCALE: NOT TO SCALE

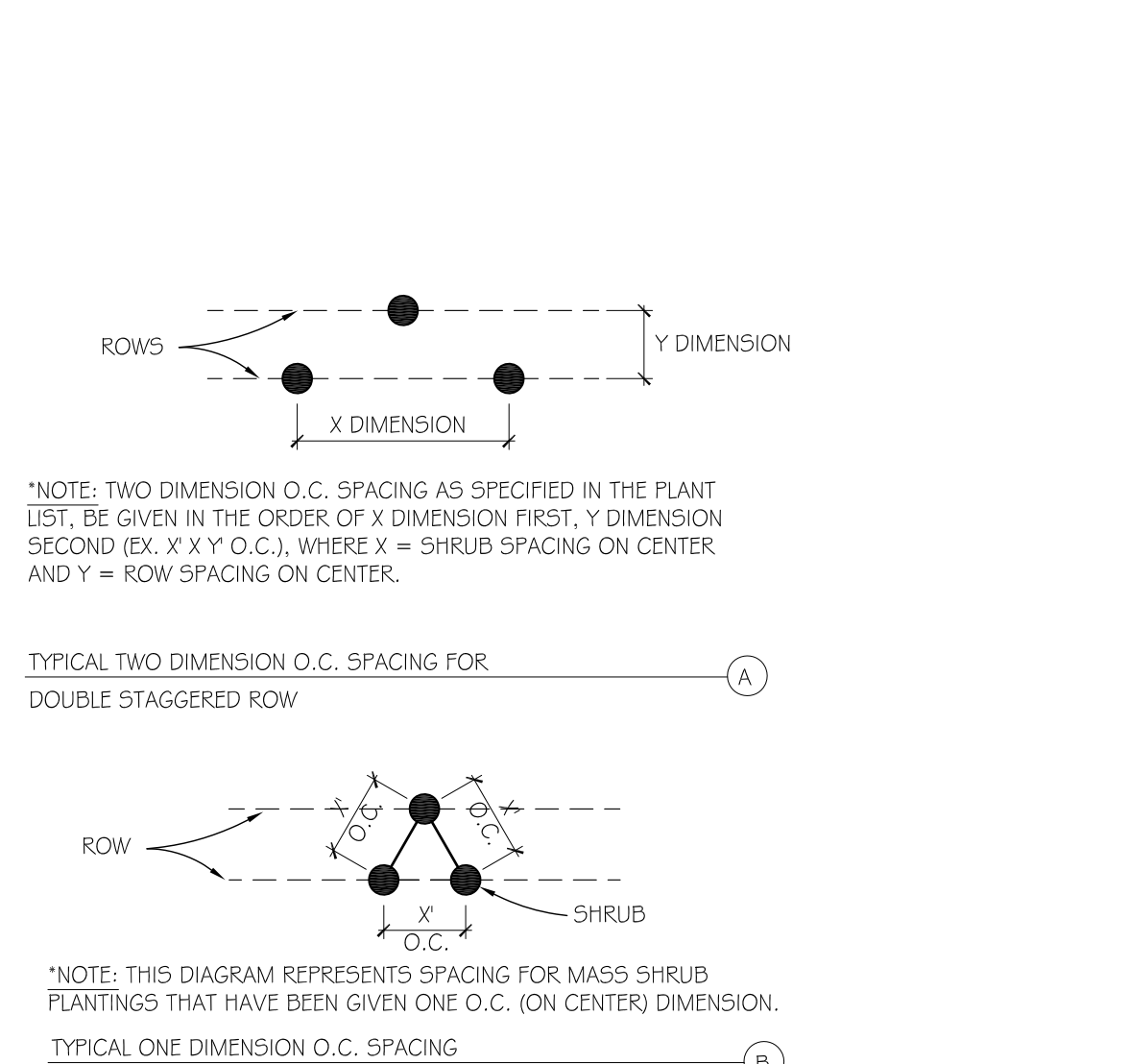

7 SHRUB SPACING DETAIL (TYP.)
SCALE: NOT TO SCALE

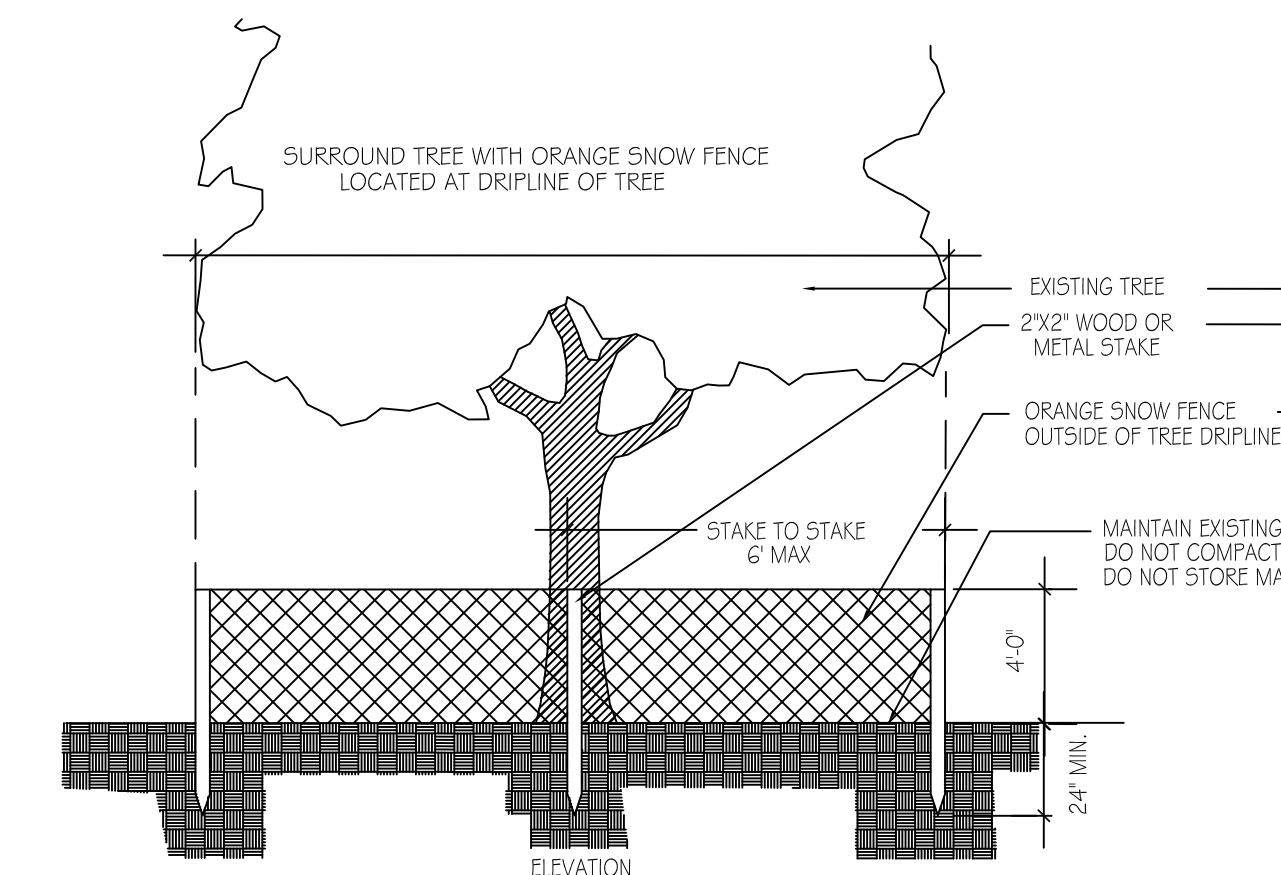

9 EXISTING TREE PROTECTION
SCALE: NOT TO SCALE

PREPARATION AND PLANTING

- NOTIFY LANDSCAPE ARCHITECT OF WORK COMMENCEMENT AND SCHEDULE.
- LANDSCAPE CONTRACTOR SHALL LOCATE ALL UNDERGROUND UTILITIES PRIOR TO STARTING WORK. OHIO UTILITIES PROTECTION SERVICE (1-800-362-2764 OUPS.org). IF A PLANT IS SHOWN ON THE PLAN WITHIN THREE FEET OF AN UNDERGROUND UTILITY, NOTIFY LANDSCAPE ARCHITECT FOR ADJUSTMENT INSTRUCTIONS.
- PROTECT STRUCTURES, UTILITIES, SIDEWALKS, PAVEMENTS, OTHER FACILITIES, LAWNS, AND EXISTING EXTERIOR PLANTS FROM DAMAGE CAUSED BY PLANTING OPERATIONS.
- PROVIDE EROSION-CONTROL MEASURES TO PREVENT SOIL EROSION OR DISPLACEMENT AND DISCHARGE OF SOIL-BEARING RUNOFF OR AIRBORNE DUST TO ADJACENT PROPERTIES AND WALKWAYS.
- LANDSCAPE CONTRACTOR SHALL LAY OUT INDIVIDUAL TREE AND SHRUB LOCATIONS AND BED EDGES FOR ALL EXTERIOR PLANTINGS. STAKE LOCATIONS, OUTLINE AREAS, ADJUST LOCATIONS WHEN REQUESTED, AND OBTAIN LANDSCAPE ARCHITECT'S, OWNER AND/OR THE OWNER'S REPRESENTATIVE WRITTEN ACCEPTANCE OF LAYOUT BEFORE PLANTING. MAKE MINOR ADJUSTMENTS AS REQUIRED PER SITE CONDITIONS.
- TREES SHALL BE SITED IN FIELD BY LANDSCAPE ARCHITECT WHERE NOTED ON PLANS.
- ALL PLANTING BEDS ARE TO BE PREPARED AS FOLLOWS:
 - LOOSEN SUBGRADE TO A DEPTH OF 6" - 7". REMOVE STONES LARGER THAN 1" IN ANY DIMENSION AND STICKS, ROOTS, RUBBISH, AND OTHER EXTRANEOUS MATTER, AND LEGALLY DISPOSE OF THEM OFF OWNER'S PROPERTY.
 - SPREAD COMPOST AT A DEPTH OF 4" AND PEAT MOSS AT A DEPTH OF 1".
 - TILL WITH LOOSENED SUBGRADE MIXING THOROUGHLY.
 - GRADE PLANTING BEDS TO A SMOOTH, UNIFORM SURFACE PLANE FOR A UNIFORM FINE TEXTURE. ROLL AND RAKE, REMOVE RIDGES, AND FILL DEPRESSIONS TO MEET FINISH GRADES.
 - EDGE BEDS 3" TO 4" DEEP (SEE DETAIL 4 ON SHEET L2.0).
- LANDSCAPE CONTRACTOR SHALL NOTIFY LANDSCAPE ARCHITECT IF SUBSOIL CONDITIONS SHOW EVIDENCE OF UNEXPECTED WATER SEEPAGE OR RETENTION IN TREE OR SHRUB PITS.
- REFER TO TYPICAL PLANTING DETAILS ON SHEET L2.0 FOR PLANT INSTALLATION.
- IT IS THE CONTRACTOR'S OPTION WHETHER OR NOT TO STAKE A TREE, BUT IT IS ALSO THE CONTRACTOR'S RESPONSIBILITY TO ASSURE PLANTS REMAIN IN AN UPRIGHT POSITION UNTIL THE END OF THE WARRANTY PERIOD. CONTRACTOR TO REMOVE STAKES & WIRE.
- PRIOR TO MULCHING, APPLY PRE-EMERGENT HERBICIDE (PREEN OR EQUIVALENT) PER MANUFACTURER'S RECOMMENDATIONS.
- IT IS THE CONTRACTOR'S RESPONSIBILITY TO:
 - KEEP ADJACENT PAVINGS AND CONSTRUCTION CLEAN, AND MAINTAIN WORK AREA IN AN ORDERLY CONDITION, FOR DURATION OF PROJECT.
 - PROTECT EXTERIOR PLANTS FROM DAMAGE DUE TO LANDSCAPE OPERATIONS, OPERATIONS BY OTHER CONTRACTORS AND TRADES, AND OTHERS. MAINTAIN PROTECTION DURING INSTALLATION AND MAINTENANCE PERIODS. TREAT, REPAIR, OR REPLACE DAMAGED EXTERIOR PLANTING.
 - REMOVE SURPLUS SOIL AND WASTE MATERIAL, INCLUDING EXCESS SUBSOIL, UNSUITABLE SOIL, TRASH, AND DEBRIS, AND LEGALLY DISPOSE OF THEM OFF OWNER'S PROPERTY.
- ALL SHRUB PLANTING BEDS AND INDIVIDUAL TREES AND SHRUBS ARE TO BE MULCHED AT A DEPTH OF 4". ALL ANNUAL, PERENNIAL, AND/OR GROUNDCOVER PLANTING BEDS ARE TO BE MULCHED AT A DEPTH OF 2".
- ALL NEW TREE RINGS SHALL BE FIVE FEET IN DIAMETER AND MULCHED PER NOTE 'M'. DO NOT PILE MULCH UP AROUND THE TREE BARK.
- ALL DECIDUOUS TREES SHALL BE WRAPPED WITH STANDARD MANUFACTURER'S TREE WRAP TO PREVENT WINTER DAMAGE WHICH SHALL BE REMOVED AFTER THE FIRST WINTER BY THE LANDSCAPE CONTRACTOR.
- ALL PLANT MATERIAL SHALL BE PRUNED AND/OR SHAPED IN ACCORDANCE WITH STANDARD HORTICULTURE PRACTICES TO RETAIN THE NATURAL CHARACTER OF THE PLANT. ALL INJURED, DAMAGED, OR CROSSED BRANCHES SHALL BE REMOVED. DO NOT REMOVE THE TREE LEADER.
- LANDSCAPE CONTRACTOR SHALL INSTALL GATOR BAGS, PER MANUFACTURER'S SPECIFICATIONS WITH ALL NON-IRRIGATED TREES.
- LANDSCAPE CONTRACTOR SHALL INSTRUCT OWNER OR OWNER'S REPRESENTATIVE ON WATERING NEEDS OF INSTALLED PLANTINGS.

WARRANTY

- CONTRACTOR SHALL PROVIDE OWNER WITH A MINIMUM ONE YEAR WRITTEN WARRANTY FOR LABOR AND MATERIALS.
- CONTRACTOR SHALL WARRANT EXTERIOR PLANTS AGAINST DEFECTS, INCLUDING DEATH AND UNSATISFACTORY GROWTH, EXCEPT FOR DEFECTS RESULTING FROM LACK OF ADEQUATE MAINTENANCE, NEGLIGENCE OR ABUSE BY OWNER, OR INCIDENTS THAT ARE BEYOND CONTRACTOR'S CONTROL.
- WARRANTY SHALL INCLUDE SPECIFIC WARRANTY PERIODS FROM DATE OF ACCEPTANCE FOR TREES AND SHRUBS, GROUND COVERS, AND OTHER EXTERIOR PLANTS.
- WARRANTY SHALL BE LIMITED TO ONE REPLACEMENT OF EACH EXTERIOR PLANT, EXCEPT FOR LOSSES OR REPLACEMENTS DUE TO FAILURE OF CONTRACTOR TO COMPLY WITH REQUIREMENTS.
- WARRANTY FOR IRRIGATION SERVICE, PLUMBING, & DRAINAGE SHALL BE GUARANTEED FOR A PERIOD OF 1 YEAR AND WILL INCLUDE START-UP, WINTERIZATION, AND SECOND SEASON START-UP. WARRANTY SHALL INCLUDE ALL LABOR, MATERIAL, TOOLS, AND EQUIPMENT AS NECESSARY TO PROVIDE A FUNCTIONING SYSTEM, FREE FROM DEFECTS AND ADJUSTED PROPERLY FOR APPROPRIATE WATER DELIVERY TO ALL PLANT MATERIAL.

SODDING

- TURFGRASS SOD SHALL BE OF GOOD QUALITY, FREE OF WEEDS, DISEASE AND INSECTS AND OF GOOD COLOR AND DENSITY.
- INDIVIDUAL PIECES OF TURFGRASS SOD SHALL BE CUT TO THE SUPPLIER'S STANDARD WIDTH AND LENGTH. MAXIMUM ALLOWABLE DEVIATION FROM STANDARD WIDTHS AND LENGTHS SHALL BE 5 PERCENT.
- STANDARD SIZE SECTIONS OF TURFGRASS SOD SHALL BE STRONG ENOUGH TO SUPPORT THEIR OWN WEIGHT AND RETAIN THEIR SIZE AND SHAPE WHEN SUSPENDED VERTICALLY FROM A FIRM GRASP ON THE UPPER 10 PERCENT OF THE SECTION.
- LANDSCAPE CONTRACTOR SHALL SOD ALL SPECIFIED AREAS. THE FINAL GRADE AND TOPSOIL WITHIN +/- .10 FEET WILL BE IN PLACE FOR SOD CONTRACTOR.
- TILL AREA TO BE SODDED TO A DEPTH OF 4". RAKE TILLED AREA TO REMOVE DEBRIS 1" OR LARGER IN SIZE THAT HAS BEEN BROUGHT TO THE SURFACE DURING TILLING.
- AFTER ALL GRADING HAS BEEN COMPLETED, THE SOIL SHALL BE IRRIGATED WITHIN 12-24 HOURS PRIOR TO LAYING THE TURFGRASS SOD. TURFGRASS SOD SHOULD NOT BE LAID ON SOIL THAT IS DRY AND POWDERY.
- THE FIRST ROW OF TURFGRASS SOD SHALL BE LAID IN A STRAIGHT LINE, WITH SUBSEQUENT ROWS PLACED PARALLEL TO, AND TIGHTLY AGAINST, EACH OTHER. LATERAL JOINTS SHALL BE STAGGERED TO PROMOTE MORE UNIFORM GROWTH AND STRENGTH. CARE SHALL BE EXERCISED TO INSURE THAT THE TURF IS NOT STRETCHED OR OVERLAPPED, AND ALL JOINTS ARE BUTTED TIGHT IN ORDER TO PREVENT VOIDS, WHICH WOULD CAUSE AIR-DRYING OF THE ROOTS.
- ON SLOPES ARE WHERE EROSION MAY BE A PROBLEM, TURFGRASS SOD SHALL BE LAID WITH STAGGERED JOINTS AND SECURED BY FEGGING.
- THE LANDSCAPE CONTRACTOR SHALL BE RESPONSIBLE FOR WATERING TURFGRASS SOD IMMEDIATELY DURING AND AFTER INSTALLATION TO PREVENT DRYING. IT SHALL THEN BE THOROUGHLY IRRIGATED TO A DEPTH SUFFICIENT THAT THE UNDERSIDE OF THE NEW TURFGRASS SOD PAD AND SOIL IMMEDIATELY BELOW THE TURFGRASS SOD ARE THOROUGHLY WET (USUALLY 1 INCH OF WATER IS NEEDED). THE GENERAL CONTRACTOR SHALL BE RESPONSIBLE FOR HAVING ADEQUATE WATER AVAILABLE AT THE SITE PRIOR TO AND DURING INSTALLATION OF THE TURFGRASS SOD.
- LANDSCAPE CONTRACTOR IS TO SET GRADE TO PROMOTE POSITIVE DRAINAGE AWAY FROM THE BUILDING AND TO DETENTION BASINS.
- UNLESS OTHERWISE SPECIFIED, THE LANDSCAPE CONTRACTOR SHALL BE RESPONSIBLE FOR MAINTAINING THE ACCEPTED SODDED TURFGRASS AREAS UNTIL THE EFFECTIVE DATE FOR TURF MAINTENANCE OPERATIONS BEGINS. THE EFFECTIVE DATE SHALL BE SPECIFIED IN WRITTEN NOTICE FROM THE GENERAL CONTRACTOR.

GENERAL LANDSCAPE NOTES

- THE CONTRACTOR SHALL VISIT THE SITE AND COMPLETELY REVIEW THESE DOCUMENTS AND FULLY UNDERSTAND THE NATURE AND SCOPE OF WORK NEEDED TO ACHIEVE THE FINISHED PRODUCT INTENDED BY THE OWNER. IN ADDITION, THE CONTRACTOR SHALL AT ONCE REPORT TO THE LANDSCAPE ARCHITECT, INACCURACIES OR INCONSISTENCIES DISCOVERED. FAILURE TO REASONABLY RECOGNIZE OR NOTIFY THE LANDSCAPE ARCHITECT OF SUCH ITEMS SHALL RELEASE THE LANDSCAPE ARCHITECT AND OWNER OF ALL LIABILITY. ANY DEVIATIONS FROM THESE DOCUMENTS WITHOUT WRITTEN APPROVAL FROM THE LANDSCAPE ARCHITECT SHALL BE CORRECTED AT THE CONTRACTOR'S EXPENSE.
- PROTECT ALL EXISTING VEGETATION TO REMAIN AS PER PLANS AND SPECIFICATIONS.
- PRIOR TO CONSTRUCTION, THE LANDSCAPE CONTRACTOR IS RESPONSIBLE FOR OBTAINING ALL PERMITS NECESSARY TO COMPLETE THE WORK, LOCATING ALL UNDERGROUND UTILITIES, AND SHALL AVOID DAMAGE TO ALL UTILITIES DURING INSTALLATION. THE LANDSCAPE CONTRACTOR IS RESPONSIBLE FOR REMEDIATING ALL DAMAGE TO UTILITIES, STRUCTURES, SITE APPURTENANCES, ETC., WHICH MAY OCCUR AS A RESULT OF LANDSCAPE CONSTRUCTION.
- CONTRACTOR MUST CERTIFY THAT ITS SAFETY PROGRAM MEETS REGULATORY REQUIREMENTS AT A MINIMUM. CONTRACTOR TO PROVIDE DOCUMENTATION OF THE OSHA RECORD KEEPING SUMMARY.
- LANDSCAPE ARCHITECT MAY OBSERVE TREES AND SHRUBS EITHER AT PLACE OF GROWTH OR SITE BEFORE PLANTING FOR COMPLIANCE WITH REQUIREMENTS FOR GENUS, SPECIES, VARIETY, SIZE, AND QUALITY. LANDSCAPE ARCHITECT RETAINS RIGHT TO OBSERVE TREES AND SHRUBS FURTHER FOR SIZE AND CONDITION OF BALLS, ROOT SYSTEMS, INSECTS, INJURIES, AND LATENT DEFECTS AND TO REJECT UNSATISFACTORY OR DEFECTIVE MATERIAL AT ANY TIME DURING PROGRESS OF WORK. LANDSCAPE CONTRACTOR SHALL REMOVE REJECTED TREES OR SHRUBS IMMEDIATELY FROM PROJECT SITE.
- IF EXISTING ECOLOGY CAUSES ADJUSTMENTS OF LANDSCAPE PLANS TO FIT THE SITE CONDITIONS, A STAKE OUT BY LANDSCAPE CONTRACTOR AND ADJUSTMENTS BY LANDSCAPE ARCHITECT SHALL BE REQUIRED PRIOR TO INSTALLATION.
- ALL PLANTING AREAS SHOWN ON PLANS SHALL BE TO WITHIN 2" OF FINAL GRADE BEFORE LANDSCAPE CONTRACTOR COMMENCES INSTALLATION.
- FOR LOCATION AND DESCRIPTION OF PROPOSED SITE UTILITIES, STORM STRUCTURES, EASEMENTS, ETC., REFER TO THE LAYOUT, GRADING PLANS, & UTILITY PLANS.
- ALL PLANT MATERIAL MUST BE INSTALLED ACCORDING TO THE APPROVED LANDSCAPING PLAN BY NO LATER THAN THE NEXT PLANTING SEASON OR WITHIN 6 MONTHS FROM THE COMPLETION OF ALL SITE CONSTRUCTION.
- CONTRACTOR TO VERIFY ALL PLANT QUANTITIES. ANY DISCREPANCY BETWEEN THE PLANTING LIST AND THE PLAN SHALL BE VERIFIED BY THE LANDSCAPE ARCHITECT. ALL SUBSTITUTIONS AND/OR CHANGES SHALL BE REQUESTED IN WRITING TO THE OWNER OR OWNER'S REPRESENTATIVE AND BE APPROVED BY THE LANDSCAPE ARCHITECT AND LIBERTY TOWNSHIP PRIOR TO INSTALLATION.
- THE CONTRACTOR SHALL PROVIDE QUALITY, SIZE, GENUS, SPECIES, AND VARIETY OF EXTERIOR PLANTS INDICATED, COMPLYING WITH APPLICABLE REQUIREMENTS IN ANSI Z60.1, "AMERICAN STANDARD FOR NURSERY STOCK."
- THE CONTRACTOR SHALL FURNISH NURSERY-GROWN TREES AND SHRUBS COMPLYING WITH ANSI Z60.1, WITH HEALTHY ROOT SYSTEMS DEVELOPED BY TRANSPARENT OR ROOT PRUNING, PROVIDE WELL-SHAPED, FULLY BRANCHED, HEALTHY, VIGOROUS STOCK, FREE OF DISEASE, INSECTS, EGGS, LARVAE, AND DEFECTS SUCH AS KNOTS, SUN SCALD, INJURIES, ABRASIONS, AND DISFIGUREMENT.
- TREES AND SHRUBS OF A LARGER SIZE MAY BE USED, IF ACCEPTABLE TO LANDSCAPE ARCHITECT, WITH A PROPORTIONATE INCREASE IN SIZE OF ROOTS OR BALLS.
- IF FORMAL ARRANGEMENTS OR CONSECUTIVE ORDER OF TREES OR SHRUBS IS SHOWN, SELECT STOCK FOR UNIFORM HEIGHT AND SPREAD, AND NUMBER LABEL TO ASSURE SYMMETRY IN PLANTING.
- THE CONTRACTOR SHALL LABEL ONE TREE AND ONE SHRUB OF EACH VARIETY AND CALIPER WITH A SECURELY ATTACHED, WATERPROOF TAG BEARING LEGIBLE DESIGNATION OF BOTH THE BOTANICAL AND COMMON NAME.
- TOPSOIL SHALL BE ASTM D 5288, pH RANGE OF 5.5 TO 7, A MINIMUM OF 4 PERCENT ORGANIC MATERIAL CONTENT; FREE OF STONES 1 INCH OR LARGER IN ANY DIMENSION AND OTHER EXTRANEOUS MATERIALS HARMFUL TO PLANT GROWTH. STANDARD TOPSOIL PLANTING MATERIAL SHALL CONSIST OF 60% NATIVE SOIL, 10% PEAT HUMUS, AND 30% COMPOST.
- COMPOST SHALL BE WELL-COMPOSTED, STABLE, AND WEED-FREE ORGANIC MATTER, pH RANGE OF 5.5 TO 8, MOISTURE CONTENT 35 TO 55 PERCENT BY WEIGHT, 100 PERCENT PASSING THROUGH ONE INCH SIEVE, SOLUBLE SALT CONTENT OF 5 TO 10 DECISEMENS/M, NOT EXCEEDING 0.5 PERCENT INERT CONTAMINANTS AND FREE OF SUBSTANCES TOXIC TO PLANTINGS.
- FERTILIZER SHALL BE SLOW-RELEASE, GRANULAR OR PELLETTED CONSISTING OF 50 PERCENT WATER-INSOLUBLE NITROGEN, PHOSPHORUS, AND POTASSIUM IN AMOUNTS RECOMMENDED FOR TYPE OF PLANT BEING GROWN.
- MULCH TO BE FREE FROM DELETERIOUS MATERIALS AND DISEASE AND SUITABLE AS A TOP DRESSING OF TREES AND SHRUBS. MULCH SHALL BE CLEAN, NON-DYED, TOXIC FREE, DOUBLE-SHREDDED HARDWOOD, DARK BROWN IN COLOR, UNLESS NOTED OTHERWISE. CRUSHED ROCK AND PEA GRAVEL OR SIMILAR MATERIALS ARE NOT ACCEPTABLE MULCH/GROUNDCOVER. ALL LANDSCAPE ISLANDS SHALL BE MULCHED BY THE LANDSCAPE CONTRACTOR UNLESS OTHERWISE STATED IN THE LANDSCAPE PLANS.
- PLANT TAGS SHALL REMAIN ON INSTALLED PLANT MATERIAL UNTIL THE WORK HAS BEEN APPROVED BY SYCAMORE TOWNSHIP INSPECTOR AND/OR THE OWNER OR OWNER'S REPRESENTATIVE.
- LANDSCAPE CONTRACTOR SHALL ASSURE POSITIVE DRAINAGE FROM ALL PLANT BEDS WITHOUT ADVERSELY AFFECTING SITE DRAINAGE. GRADES BEHIND CURBS FOR AREAS TO RECEIVE MULCH SHALL BE HELD 4 INCHES BELOW TOP OF CURB AND 2 INCHES BELOW TOP OF CURB FOR SOD.
- THE LANDSCAPE CONTRACTOR IS RESPONSIBLE FOR FULLY MAINTAINING, INCLUDING, BUT NOT LIMITED TO, WATERING, SPRAYING, MULCHING, FERTILIZING, ETC., ALL PLANTING AREAS AND LAWN UNTIL THE WORK IS ACCEPTED BY THE OWNER OR THE OWNER'S REPRESENTATIVE.
- ALL PLANT MATERIAL INSTALLATION TO BE COORDINATED WITH IRRIGATION CONTRACTOR. ACTIVATE IRRIGATION SYSTEM UPON COMPLETION OF ALL LAWN AREAS.
- ALL IRRIGATION COMPONENTS SHALL BE OF THE SAME MANUFACTURER & INSTALLED PER MANUFACTURER SPECIFICATIONS.
- IRRIGATION CONTRACTOR TO SUPPLY, INSTALL, AND TEST BATTERY OPERATED IRRIGATION CONTROLLER @ BACKFLOW PREVENTER LOCATION. IRRIGATION SCHEDULE SHALL BE COORDINATED WITH THE CITY OF CRESTVIEW HILLS MAINTENANCE SUPERVISOR.

SEEDING

- LANDSCAPE CONTRACTOR SHALL SEED ALL DISTURBED AREAS. THE FINAL GRADE AND TOPSOIL WITHIN +/- .10 FEET WILL BE IN PLACE FOR SEEDING CONTRACTOR.
- CONTRACTOR SHALL APPLY CELLULOSE FIBER MULCH AT A MINIMUM RATE OF 1500 LBS./ACRE AND FERTILIZERS: BEST 6-20-20 OR BEST 15-15-15 OR APPROVED EQUAL APPLIED AT RATE APPROPRIATE FOR PRODUCT. ORGANIC TACKIFIER SHALL BE APPLIED AT RATE OF 70 LBS./ACRE. HYDROSEED MIX SHALL BE APPLIED AT THE 2,000 LBS./ACRE.
- CONTRACTOR SHALL WATER ALL PLANT AREAS THOROUGHLY TO SATURATE UPPER LAYERS OF SOIL PRIOR TO THE HYDROSEEDING OPERATION. ALLOW THE PLANTING AREA SOIL SURFACE TO DRY OUT FOR ONE DAY ONLY PRIOR TO THE HYDROSEEDING APPLICATION.
- CONTRACTOR SHALL APPLY THE HYDROSEEDING IN THE FORM OF A SLURRY CONSISTING OF ORGANIC SOIL AMENDMENTS, COMMERCIAL FERTILIZER, AND ANY OTHER CHEMICALS THAT ARE CALLED OUT, WHEN HYDRAULICALLY SPRAYED ONTO THE SOIL. THE MULCH SHALL FORM A BLOTTER-LIKE MATERIAL. SPRAY THE AREA WITH A UNIFORM VISIBLE COAT, USING THE DARK COLOR OF THE CELLULOSE FIBER AS A VISUAL GUIDE. THE SLURRY SHALL BE APPLIED IN A DOWNWARD DRILLING MOTION VIA A FAN STREAM NOZZLE. CONTRACTOR SHALL INSURE THAT ALL OF THE SLURRY COMPONENTS ENTER AND MIX WITH THE SOIL.
- IF SLURRY COMPONENTS ARE LEFT FOR MORE THAN TWO HOURS IN THE MACHINE, ADD 50% MORE OF THE ORIGINALLY SPECIFIED SEED MIX TO ANY SLURRY MIXTURE WHICH HAS NOT BEEN APPLIED WITHIN THE TWO HOURS AFTER MIXING. ADD 75% MORE OF THE ORIGINAL SEED MIX TO ANY SLURRY MIXTURE WHICH HAS NOT BEEN APPLIED EIGHT (8) HOURS AFTER MIXING. ALL MIXTURES MORE THAN EIGHT (8) HOURS OLD, SHALL BE DISPOSED, OFFSITE, AT THE CONTRACTOR'S EXPENSE.
- CONTRACTOR SHALL REMOVE ALL SLURRY SPRAYED ONTO HARDSCAPE AREAS INCLUDING CONCRETE WALKS, FENCES, WALLS, BUILDINGS, ETC., AT THE CONTRACTOR'S EXPENSE.
- CONTRACTOR SHALL SAVE ALL SEED AND FERTILIZER TAGS AND FIBER MULCH BAGS FOR THE LANDSCAPE ARCHITECT TO VERIFY COMPLIANCE WITH THE DRAWINGS AND SPECIFICATIONS.

Plot time: Oct 19, 2012, 4:21pm
Drawing name: J:\2007\07M028-002\LADW\G07M028-002_LP.dwg - Layout Tab: L 2.0

THIS DOCUMENT AND ALL RELATED DETAIL DRAWINGS, SPECIFICATIONS, AND ELECTRONIC MEDIA PREPARED OR FURNISHED BY BAYER BECKER (BB), ARE INSTRUMENTS OF PROFESSIONAL SERVICE, AND IS THE EXCLUSIVE PROPERTY OF BB. NO DISCLOSURE, REPRODUCTION, OR DUPLICATION IN WHOLE, OR IN PART, MAY BE MADE WITHOUT WRITTEN PERMISSION OF BB, AND IS DONE SO AT USER'S SOLE RISK. COPYRIGHT - ALL RIGHTS RESERVED.

PRELIMINARY

Item	Revision Description	Date	Drawn	Chk
1				

KENWOOD CITY PLACE
8080 MONTGOMERY ROAD
SYCAMORE TOWNSHIP
HAMILTON COUNTY, OHIO

bayer becker
www.bayerbecker.com
6900 TYLERSVILLE ROAD, SUITE A
MASON, OH 45504-5133.336.6600

LANDSCAPE NOTES & DETAILS

Drawing: 07M028-002_LP
Drawn by: CJM
Checked by: JAB
Issue Date: 10-18-2012
Sheet: **L 2.0**