

COLERAIN TOWNSHIP BOARD OF TRUSTEES

RESOLUTION NO. 17-09

ADOPTING TEXT AMENDMENTS TO THE
ZONING RESOLUTION RELATING TO OUTDOOR WOOD FURNACES

WHEREAS, said proposed text amendments permitting and regulating outdoor wood furnaces were initiated by the Colerain Township Zoning Commission at its meeting on October 21, 2008 and considered following a public hearing on November 18, 2008; and

WHEREAS, by motion and vote at its regular meeting on November 18, 2008, the Zoning Commission recommended approval of said text amendments; and

WHEREAS, the Board of Trustees held a public hearing on January 13, 2009 and, at the conclusion of the public hearing, voted to accept the recommendations of the Zoning Commission as set out in Exhibit A;

NOW, THEREFORE, BE IT RESOLVED by the Board of Trustees of Colerain Township, Hamilton County, Ohio, that:

The Board does hereby adopt the amendments to the Colerain Township Zoning Resolution attached hereto as Exhibit A.

Adopted in regular session on this 10th day of February, 2009.

BOARD OF TRUSTEES
COLERAIN TOWNSHIP,
HAMILTON COUNTY, OHIO

Attest:

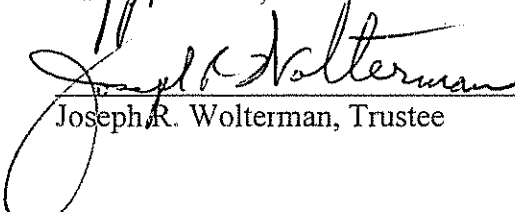

Heather Harlow, Township Fiscal Officer

Jeffrey F. Ritter, Trustee

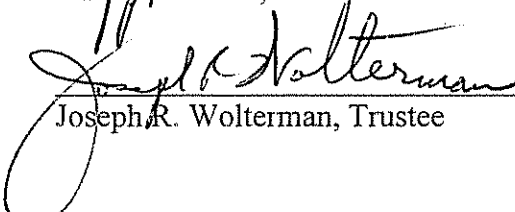
Joseph R. Wolterman, Trustee

Bernard A. Fiedeldej, Jr., Trustee

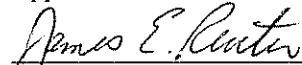
Approved as to form:

James E. Reuter (0011414)
3025 W. Galbraith Road
Cincinnati, Ohio 45239-4222
(513) 521 - 8400
Attorney for Board of Trustees

Colerain Township – Case ZA2008-05 – Text Amendment

Article 10.2.3 (A) (8) Outdoor Wood Furnaces.

- (8) Outdoor Wood Furnaces shall be permitted, subject to all requirements as provided herein.
- (a) All Outdoor Wood Furnaces shall be constructed, established, installed, operated and maintained in conformance with the manufacturer’s instructions and the requirements of all applicable agencies, including but not limited to Ohio EPA regulations regarding emissions and equipment labeling.
 - (b) Fuel burned in any new or existing Outdoor Wood Furnace shall be only natural untreated wood, wood pellets, corn products or other listed fuels specifically permitted by the manufacturer’s instructions such as fuel oil, natural gas or propane backup, except where such list may be in conflict with the list of prohibited fuels below.
 - (c) The following fuels are strictly prohibited in new or existing Outdoor Wood Furnaces:
 - (1) Wood that has been painted, varnished, or coated with similar material and/or has been pressure treated with preservatives, and/or contains resins or glues as in plywood or other composite wood products.
 - (2) Rubbish or garbage, including but not limited to food wastes, food packaging, food wraps.
 - (3) Any plastic materials including but not limited to nylon, PVC, ABS, polystyrene or urethane foam, and synthetic fabrics, plastic films and plastic containers.
 - (4) Rubber including tires or other synthetic rubber-like products.
 - (5) Newspaper, cardboard, or any paper with ink or dye products.
 - (6) Any other items not specifically allowed by the manufacturer or this provision.
 - (d) Setbacks for any new Outdoor Wood Furnace:
 - (1) The Outdoor Wood Furnace shall be located a minimum of 25 feet from all property lines and a minimum of 100 feet from any residence that is not served by the outdoor wood furnace. See Figure 10.1.
 - (2) The Outdoor Wood Furnace shall be located on the property in compliance with manufacturer’s recommendations and or testing and listing requirements for clearance to combustible materials.
 - (e) Chimney heights for outdoor wood furnaces shall not be subject to the accessory structure height limitations defined in §10.2.3 (B), but shall be determined as follows.
 - (1) The Outdoor Wood Furnace chimney shall extend either 20 feet above the ground surface or at least 2 feet above the peak of any residence not served by the Outdoor Wood Furnace located within 300 feet of such Outdoor Wood Furnace, whichever is greater. See Figure 10.1.

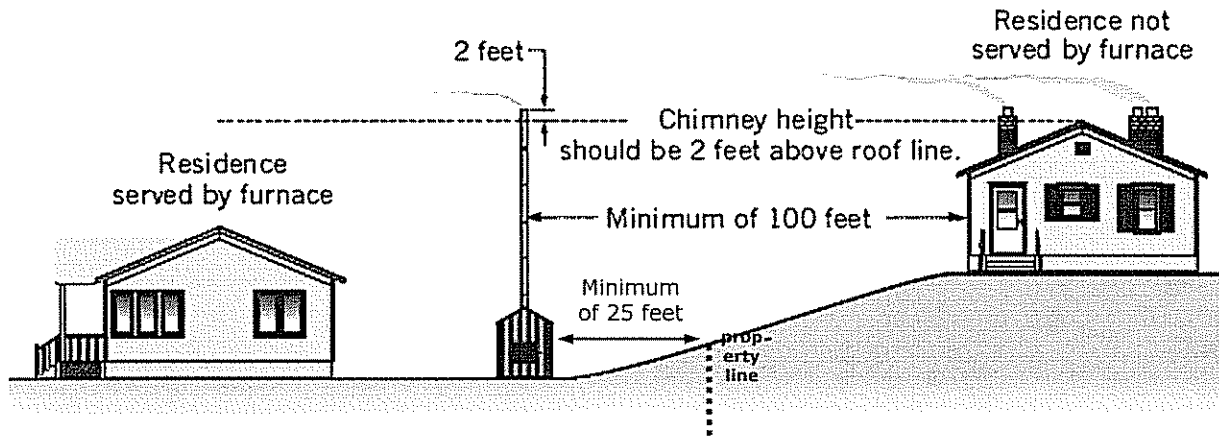

Figure 10.1

- (2) If there is an existing Outdoor Wood Furnace already installed and there is new construction of a residence not served by the Outdoor Wood Furnace within 300 feet of such Outdoor Wood Furnace then the owner of such Outdoor Wood Furnace shall conform to the stack height requirements of this regulation within 30 days of the date such construction is complete and upon written notice from the Zoning Administrator.
- (f) All outdoor wood furnaces shall include an integral enclosing structure or shall be enclosed by a structure, subject to the accessory structure standards defined in §10.2.

Add to Article 16 - Definitions

Outdoor Wood Furnace shall mean any equipment, device, appliance or apparatus, or any part thereof, which is installed, affixed or situated outdoors for the primary purpose of combustion of fuel to produce heat or energy used as a component of a heating system providing heat for any interior space or water source. An Outdoor Wood Furnace may also be referred to as an Outdoor Wood Boiler or Outdoor Wood Hydronic Heater.

Outdoor Wood Furnace Chimney shall mean any flue or stack that carries off exhaust from an Outdoor Wood Furnace firebox or burn chamber.