

CITY OF CARLSBAD

NEW MEXICO



PUBLIC INFRASTRUCTURE

SPECIFICATIONS

Adopted July 2019

(Res. No. 2019-29)

Prepared For:
City of Carlsbad
101 N. Halagueno St.
Carlsbad, NM 88220

Prepared By:
City of Carlsbad
114 S. Halagueno St.
Carlsbad, NM 88220

TABLE OF CONTENTS

Article 1 - General Statement of Policies and Specifications

1	General	Page 1
2	Definitions	Page 2
3	Engineering Acceptance, Construction, Testing and Inspection Services	Page 6
4	Permits	Page 7
5	General Technical Provisions.....	Page 7
6	Infrastructure Checklist.....	Page 11

Article 2 - Standard Specifications for Streets and Street Related Construction

7	General	Page 1
8	Street Classification and Geometric Design Standards	Page 1
9	Pavement Design Standards.....	Page 2
10	Engineering Data.....	Page 5
11	Construction Specifications	Page 6
	Typical Section for Local Streets	

Article 3 - Standard Specification for Excavation Under Paved Streets and Alleys

1	General	Page 1
2	Provisions for Excavation	Page 1
3	Specification for Excavation and Backfill	Page 1
	Standard Details of Construction	

Article 4 - Standard Specification for Excavation Not Under Paved Streets or Alleys

1	General	Page 1
2	Provisions for Excavation	Page 1
3	Specification for Excavation and Backfill	Page 1
	Standard Details of Construction	

Article 5 - Standard Specification for the Construction of Alleys

1	General	Page 1
2	Alley Widths.....	Page 1
3	Engineering Data.....	Page 1
4	Standard Specifications.....	Page 2
	Standard Details of Construction	

Article 6 - Standard Specifications for Sidewalk, Fillet and Drivepad Construction

1 General Page 1
2 Policies Regarding Sidewalk and Drivepad Construction Page 1
3 Standard Specification for Placement of Sidewalk Page 1
4 Standard Specifications for Placement of Drivepad..... Page 2
5 Standard Specifications for Placement of Concrete Fillet Page 3
Standard Details of Construction

Article 7 - Standard Specification for Curb Construction, Cuts and Replacement

1 General Page 1
2 Engineering Data..... Page 1
3 Standard Specifications for Curb Cuts..... Page 1
Standard Details of Construction

Article 8 - Standard Specification for Utilities

1 Interruption of Service and Notice Page 1
2 Connection to Existing System Page 1
3 Public Convenience and Access Page 2
4 Source of Supply and Quality of Materials..... Page 2
5 Railroad and State Highway Crossings Page 2
6 Utility Stubouts Page 2
7 Construction Notes..... Page 3
8 Utility Services Line Replats Page 3
9 Tracer Wire Specification Page 4
10 Test Forms Page 5

Article 9 - Standard Specification for Boring, Drilling and Jacking

1 Description Page 1

Article 10 - Standard Specification for Water Lines

1 Description Page 1
2 Materials..... Page 1
3 Construction Requirements Page 2
Standard Details of Construction

Article 11 - Sanitary Sewer Lines

1 Description Page 1
2 Materials..... Page 1
3 Construction Requirements Page 2

Article 12 - Standard Specification for Manholes

1 Description Page 1
2 Construction Requirements Page 1
Standard Details of Construction

Article 13 - Policy on Fire Line Systems

1 General Page 1

Article 14 - Street Lighting

1 General Page 1
2 Night Sky Protection Act Page 1

Article 15 - Storm Drainage

1 General Page 1
2 Drainage Analysis Criteria Page 2
3 Hydraulic Criteria Page 6
4 Detention Facilities Page 7
5 Submittal Requirements - Residential Subdivisions Page 10
6 Submittal Requirements - Commercial and Industrial Developments
or Subdivisions Page 12

Appendix A: City of Carlsbad Contact Information

ARTICLE 1

GENERAL STATEMENT OF POLICIES AND SPECIFICATIONS

Purpose

The design standards in this document are to provide for the harmonious development of the City and its environs in order to establish conditions favorable to the health, safety, convenience, and general welfare of citizens of the City. More specifically, this document is designed to achieve the following objectives in newly developed areas:

- A. Adequate provisions for light and air, public rights-of-way, public open spaces, and drainage and private property utilized by the public.
- B. Safe, convenient circulation of people, goods, and vehicles.
- C. Coordination of land development in accordance with orderly physical patterns as stated in the adopted plans and polices as may have been or may be adopted by City Council.

1. General

The policies and specifications herein contained are adopted by the City of Carlsbad (Resolution No. 2015-10).

The following documents and standards, as amended from time to time, are hereby incorporated into these specifications by reference, with the express exception of the terms, provisions, and sections indicated in this document.

- 1) City of Carlsbad Subdivision Ordinance No. 2013-05.
- 2) City of Carlsbad Zoning Ordinance No. 2011-15, Ordinance No.2016-18 Ordinance No. 2017-19
- 3) New Mexico State Department of Transportation, "Standard Specifications for Highway and Bridge Construction", 2014 Edition.
- 4) New Mexico Standard Specifications for Public Works Construction, 2006 Edition, NMAPWA. (NMSSPWC)
- 5) Federal Highway Administration, "Manual of Uniform Traffic Control Devices",

2009 Edition. (MUTCD)

- 6) America Association of State and Highway Transportation Officials. (AASHTO)
- 7) American Water Works Association. (AWWA)
- 8) American Concrete Institute. (ACI)
- 9) Where applicable, the technical provisions contained shall be considered the minimum requirements to meet the purpose. The Engineer/Developer/Applicant may submit alternative or site-specific details for approval by the City of Carlsbad.
- 10) Local conflicts. Where provisions of any local ordinance, regulation, or covenant impose greater restriction than those of this document, the provisions of such greater restrictions shall prevail.
- 11) State and Federal conflict. Any provision of the Federal or State law, which imposes a greater duty, standard, or requirement than that contained in this document, shall supersede this document.

The **most current edition** of each of the above cited publications shall be considered in use by this document.

*The point of contact for all documents, questions, requests for any interpretation of this specification, permits, etc. shall be the City of Carlsbad's Planning, Engineering & Regulation Department (P.E.R.D.) located at 114 S. Halagueno Street, Carlsbad, New Mexico 88220. The contact phone number is 575-885- 1185. Any work performed within the Public Right-Of-Way requires that all permits, fees, approvals, etc. be obtained and approved prior to construction.

2. **Definitions**

For the purpose of this Ordinance, the words and terms used herein shall be defined and interpreted as follows:

Abut/Abutting/Adjacent/Adjoining/Contiguous. Lots or parcels separated by common property lines, lot lines, or an alley, street or other public right-of-way.

Agent. The owner's representative who shall have express authority to act on behalf of that owner. Written consent shall be required from the legal owner of the premises.

Applicant. A person submitting an application in accordance with the procedures established in these specifications.

Block. A parcel of land entirely surrounded by streets or highways, railroad right-of-way, waterways or by a combination thereof.

City. The City of Carlsbad.

City of Carlsbad. The City of Carlsbad's representative in direct responsible charge of the work to be performed.

Comprehensive Plan. That document or documents adopted by the City Council as the City of Carlsbad's Comprehensive Plan or portions thereof.

Construction Plan Drawings. The drawings, as prepared by a New Mexico Registered Engineer, accompanying a subdivision plat or other development and showing the specific location and design of improvements to be installed in the subdivision in accordance with the requirements of this Ordinance and other ordinances.

Controlled Access Highway. A roadway where direct access to abutting properties is prohibited and where access is provided only at designated intersections with major arterial streets or major collector streets.

Covenant. A recorded condition entered into between private parties and constituting a restriction on the use of all private property within a subdivision or development for the mutual benefit of successive property owners. Covenants are private agreements and are not subject to the jurisdiction of the City.

Curb Return. The access radius for an intersection or driveway opening, also referred to as Radius Return.

Detention Pond. A pond or drainage facility designed to temporarily hold, store, or otherwise detain storm flows with the intent of releasing the storm flows at a controlled rate.

Developer. The legal or beneficial owner of a lot or of any land included in a proposed development, the holder of an option or contract to purchase, or any other person having enforceable proprietary interest in such land.

Easement. A right of use over the property of another for a specific purpose.

Encroachment permit. A permit required prior to the commencement of any work or construction within the City of Carlsbad's public rights-of-way.

Engineer. A registered professional engineer in good standing with the New Mexico Board of Registration for Engineers and Surveyors.

Excavation. A hole, trench, ditch or depression in a public place or right-of-way, resulting from the removal of pavement, dirt, or other material.

Financial Guarantee. Performance Bond or Letter of Credit.

Floodplain. Any land subject to a one (1) percent or greater chance of flooding in any given year as indicated on the most recent maps published by the Federal Emergency Management Agency (FEMA) and adopted by the City of Carlsbad. This area is typically called the “100 year floodplain”.

Frontage. The distance measured along a right-of-way, property line, or access easement.

Grade. The slope of a road, street, alley, utility or facility specified as a percentage.

Improvement. Any addition made to a piece of property intended to enhance its value, utility, or beauty, or to adapt it for new and further uses.

Lot. A portion of a legally platted subdivision that is shown on the records of the County Clerk as a lot, tract, or parcel of land and held in separate ownership. A portion of land that was subdivided from other land in accordance with the then existing zoning and subdivision requirements.

Lot area, gross. A measurement of the total area contained within the boundaries of a lot, expressed in square feet, acres or other appropriate units, prior to the deduction of area for streets, alleys, easements, or other public spaces.

Lot area, net. A measurement of the total area contained within the boundaries of a lot, expressed in square feet, acres or other appropriate units, after the deduction of area for streets, alley, easements or other public spaces.

Lot, corner. A lot situated at the intersection of two (2) streets, the interior angle of such intersection not exceeding one hundred thirty-five (135°) degrees.

Lot depth. The horizontal distance between the front and rear lot lines.

Lot, double frontage. A lot having a frontage on two (2) non-intersecting streets as distinguished from a corner.

Lot, interior. A lot other than a corner lot.

Lot lines. The property lines bounding a lot.

Lot line, front. The boundary of a lot abutting a street right-of-way.

Lot line, rear. A lot line which is most distant from and/or is approximately parallel to the front lot line.

Lot line, side. A lot line which is not a front lot line or a rear lot line.

Lot width. The horizontal distance between the side lot lines as measured along the front property line.

Mobile home park. A parcel or lot designed and developed for long-term residential use and intended for rent or lease where the residents live in mobile homes or manufactured homes exclusively.

Monument. A permanent, physical item used as a survey control point.

Off-site. Any premises not located within the area of the property to be developed, whether or not in the common ownership of the applicant.

Owner. Any person who has legal control of, or title to real property or a structure.

Plat. A map, survey, drawing or plan certified by a licensed land surveyor containing a description of the subdivided land with ties to permanent monuments.

Public Works Project. Any improvement, alteration, or repair of existing public infrastructure, including public streets, curb, gutter, sidewalk, water utility, wastewater utility, storm water utility, drainage utility, lighting, or other infrastructure owned and maintained by the City of Carlsbad, or any new development approved by the City of Carlsbad which will be dedicated as public infrastructure to be owned and maintained by the City of Carlsbad.

Retention Pond. A pond or drainage facility designed to permanently hold, store, or otherwise retain storm flows without the intent of releasing the storm flows.

Right-of-way. A strip of land opened, reserved, or dedicated for a street, sidewalk, utility, drainage, or other public purpose. A right-of-way shall be dedicated to public use by the maker of the plat on which such right-of-way is established.

Roadway. That portion of a street right-of-way developed for vehicular traffic.

Setbacks. Unobstructed, unoccupied, open areas, measured at its shortest distance as follows:

- (a) *Street or front setback.* The street or front setback shall be the distance between the front building line and the front property line or street right-of-way line, or street easement whichever is closer. If there is no street right-of-way line, then it shall be the shortest distance between the front building line and the nearest edge of the street or curb, whichever is closer.
- (b) *Side setback.* The side setback is the distance between the side building line and the side property line.
- (c) *Rear setback.* The rear setback is the distance between the rear building line and the rear property line.
- (d) The City may, at its sole discretion, designate which side of the property is the front, side, and rear.
- (e) No yard, setback, or other open space provided around any structure for the purpose of complying with provisions of this Code shall be considered as providing a yard, setback, or open space for any structure on any other lot.

Street. A dedicated public way for vehicular traffic, whether designated as an avenue, boulevard, thoroughfare, road, highway, expressway, lane, drive, alley or any other public way.

Street, alley. Alleys are minor public ways used primarily for service access to the back or side of properties otherwise abutting on a street.

Street, arterial. Those streets so designated and designed to carry high traffic volumes or to function as major thoroughfares.

Street, collector. Those streets so designated and designed to carry moderate traffic volumes and function as connections between residential streets and arterial streets.

Street, cul-de-sac or dead end. A street having one open end and being permanently terminated by a vehicle turnaround.

Street, frontage. A street adjacent to an arterial street, separated therefrom by a dividing strip and providing access to adjacent properties.

Street jog. A portion of a street that curves to the left or right before continuing through an intersection.

Street, local. Those streets which primarily permit direct access to abutting lands and connect to collector and arterial streets.

Street, loop. Those streets that are open at both ends and connected to only one residential street.

Street, residential. Those streets so designated and designed to carry low traffic volumes primarily through residential areas and neighborhoods.

Street, rural. Those streets designed to carry very low traffic volumes.

Subdivider. Any person, firm, corporation or other entity subdividing land within the jurisdiction of the City's Subdivision Ordinance.

Subdivision. The division of a tract, parcel or lot into two (2) or more lots or building sites, or other divisions for the purpose, whether immediate or future, of sale, legacy, or building development and includes all divisions of land involving a new street or a change in existing streets and includes a re-subdivision and, where appropriate, relates to the process of subdividing or to the land or area subdivided.

Substantial Completion. The stage at which a construction or building project, or portion thereof, is sufficiently complete in accordance with the construction documents and/or contract, so that the owner may occupy and/or utilize the building, facility, utility, street, etc. for its intended use or purpose, without undue interference.

Surveyor. A registered land surveyor in good standing with the New Mexico Board of Licensure for Professional Engineers and Surveyors.

Tract. The term "tract" may be used interchangeably with the term "lot", particularly in the context of subdivision, where a "tract" may be subdivided into several lots, parcels or tracts.

Traffic Impact Analysis (TIA). A technical study performed by a qualified engineer, which assesses the impact of a proposed facility or development on existing and proposed rights-of-way. It may analyze the impact on safety, intersections, circulation patterns, ingress/egress, traffic loads, parking and loading areas, on-site circulation and vehicles per day and may set forth mitigation measures to eliminate or substantially reduce such impacts. Also referred to as a "traffic study".

Trustee. An individual or firm, licensed under the escrow law of the State of New Mexico, acting as the third party in an financial guarantee.

Vacation. The act of rescinding (cancelling) any right-of-way, easement, public area, other public interests, or any part of a recorded subdivision in accordance with State statutes.

3. *Engineering Construction, Testing, and Inspection Services*

- A. General - The design of all Public Works projects or any potential dedications shall be performed under the supervision of a New Mexico Registered Engineer. The construction of all Public Works projects shall be performed only by Contractors appropriately licensed by the State of New Mexico.
- B. Engineering Services - Persons retained to perform engineering services for any Public Works projects shall provide all the engineering information required for such work as stipulated in the sections herein contained. In cases where additional data is required, it shall be provided as requested by the City of Carlsbad.
- C. Construction Services - Persons retained to perform construction services for any Public Works projects shall comply with all specifications regarding the type of work undertaken as contained herein. All construction work shall require the final inspection and approval of the City of Carlsbad before final acceptance. All significant changes to the design or construction must be documented and approved by the City of Carlsbad prior to the change being made.
- D. Testing Services - Quality control testing shall be performed on all Public Works projects by a Certified Testing Lab on all construction projects undertaken in public rights-of-way. The contractors shall be responsible for complying with all testing requirements. Lab Certifications shall include but not be limited to:
- National Institute for Certification in Engineering Technologies (NICET) - Level II certification in highway materials; or
 - State Department of Transportation (NMDOT) and Federal Highway Administration (FHWA) Certifications, as applicable; or
 - Industry certifications for sampling and testing directly related and equivalent to the sampling and testing to be performed; or
 - Western Alliance for Quality Transportation Construction (WAQTC) or other nationally accepted certification program for intended sampling and testing.
- E. Pre-Construction Conference – A pre-construction conference shall be held prior to beginning any construction for any approved Public Works project. Attendance by the City of Carlsbad staff, Engineer, Contractor and Developer representative is mandatory.

- F. "As Built" Drawings - The Contractor, in coordination with the project Engineer, shall prepare an accurate set of "As Built" drawings for all Public Works projects (streets, alleys, utilities, etc.). The Contractor shall record thereon the locations, depths, sizes, types of material, any other pertinent data, and all changes made during construction that differ from the approved construction drawings. The Contractor shall provide to the City of Carlsbad, prior to acceptance of the project by the City, two (2) hard copies, one (1) PDF file and one (CAD) file.
- G. Final Acceptance – Prior to acceptance by the City, a letter of certification signed by the project engineer must be submitted to the City of Carlsbad upon completion of any construction performed for a Public Works project. The certifications must be accompanied by copies of testing reports, as-built drawings, infrastructure checklist, and any other information requested by the City of Carlsbad signifying that the work was completed in accordance with these Specifications.
- H. Inspection of Work - All work performed in an approved Public Works project is subject to inspections. All inspections required under each section of this document shall be the responsibility of the Contractor or Developer in the case of new development. The City shall be given a 48 hour notification before the installation of any pertinent infrastructure to be dedicated to the City. The City's Infrastructure Inspectors, or any other person identified by the City as an inspector for a specific Public Works project, shall be allowed to enter the property on which the project is located, and allowed to inspect any and all work as it pertains to the portion of the project that will be dedicated to the City, as identified by the City Lab tests and lab reports related to the work being done shall be submitted to the City. The City, as owner, reserves the right to reject any and all work that does not meet the Standard Specifications. The City also reserves the right to request additional lab or field tests for the work being inspected. This additional testing shall be at the Developers/Contractors expense. The City reserves the right to make all final inspections and require additional testing necessary to determine whether or not a project is to be accepted.

4. Permits

An Encroachment Permit is required prior to commencement of any work within the City of Carlsbad for any Public Works project. The point of contact for Encroachment Permits, documents, questions and other required permits is the City of Carlsbad's Planning, Engineering & Regulation Department, located at 114 S. Halagueno Street,

Carlsbad New Mexico 88220. The contact phone number is 575-885-1185. Any work performed as part of a Public Works project requires that all permits, fees, approvals, etc. be obtained and approved prior to construction.

5. General Technical Provisions

The items under this section shall apply to all types of work undertaken as part of a Public Works project.

- A. Relocation and Protection of Existing Utilities - The applicant may not interfere with any existing utility without written consent of the owner of the utility. Any relocation of an existing utility, if deemed necessary by the applicant, is to be done by the utility owner. No utility owned by the City may be moved to accommodate the applicant, except at the applicant's expense. The cost of moving privately owned utilities also will be at the expense of the applicant unless otherwise agreed. The applicant must do everything necessary to support, sustain, and protect all utilities under, over, along, or across said work area. In the event said utilities are damaged (and for this purpose, pipe coating or other encasement or devices are to be considered as part of a substructure) the utility owner must be notified immediately. The applicant shall call for all utility locates from New Mexico State One Call a minimum of 48 hours in advance of commencement of work. In addition, the Contractor shall make every effort to contact the owners of any private individual utilities.
- B. Routing of Traffic – During the performance of all work, the applicant must take appropriate measures to maintain traffic conditions as near to normal as practicable in order to minimize inconvenience to adjacent properties and the general public. The City of Carlsbad may require that the applicant to notify, in writing, various public agencies and the general public of proposed work prior to issuance of a permit. A traffic control plan, following the Manual on Uniform Traffic Control Devices (MUTCD), latest edition, will be submitted to the City of Carlsbad for approval a minimum of fourteen (14) Calendar days, prior to the beginning of construction operations, or in an emergency as practicable.
- C. Clearance of Vital Structures - All work must be performed and conducted so as not to interfere with access to fire hydrants, fire stations, fire escapes, and all other vital structures or equipment as deemed by the City.
- D. Protection of Traffic - The applicant must maintain a safe crossing of two lanes of vehicle traffic at all street intersections, where possible, and safe crossings for pedestrians at intervals of not more than 300 feet. If any work is across any public street, alley or sidewalk, at least one safe crossing must be maintained

when possible for vehicles and pedestrians. If the construction prohibits pedestrian sidewalk access, an approved passageway of the sidewalk width must be provided, including appropriate signage.

- E. Road Closures - Where partial or complete road closures are necessary, public notice of such closures shall be made in local newspapers and radio stations no later than 48 hours in advance of the closure. Routing of traffic around the closure shall be as shown in the approved Traffic Control Plan (see "Routing of Traffic", paragraph B above). In addition, the applicant shall notify the City's Police Department, Fire Department, City Transit, and Eddy County Emergency Services if applicable. The Contractor shall provide and maintain access to private residences and businesses at all times during the project.
- F. Protection of Adjoining Property - The applicant must, at all times and at his/her own expense, preserve and protect from injury any adjoining property by taking suitable measures for this purpose. Where it is necessary to enter upon private property for the purpose of taking appropriate protective measures, the applicant must (unless otherwise provided by law) obtain permission from the property owner. The applicant must, at his/her own expense, shore up and protect all buildings, walls, fences, or other property that may be damaged during the progress of any work, and be responsible for all damages to public or private property resulting from his failure to properly protect and carry out such work. This provision shall also include any damages due to vibratory equipment. The applicant may not remove, even temporarily, any trees or shrubs which exist in any public right-of-way or public property without first obtaining the written consent of the City.
- G. Protection of Water Courses – At all times, the applicant must maintain all water courses free and unobstructed for the full depth, or provide an adequate temporary substitute to include all federally required NPDES permits.
- H. Cleanup – At his/her expense, applicants are responsible for the cleanup of all rubbish, excess earth, rock and other debris resulting from any approved Public Works project. From time to time, as may be ordered by the City of Carlsbad and in every event immediately after completion of such work, the applicant must clean up and remove, and properly dispose of all refuse, dirt and unused materials of any kind resulting from said work. Failure to start the cleanup within two (2) Working Days after notification may require the work be done by the City, and the cost thereof charged to the applicant.
- I. Prompt Completion of Work - After any work is commenced, the applicant must

proceed with diligence to complete all work included in the approved Public Works project or covered by the particular permit, and must promptly restore the public place to pre-construction condition, or as near as possible, so as not to obstruct the public right-of-way more than reasonably necessary.

- J. Emergency Work - If determined by the City of Carlsbad that traffic conditions, public safety or convenience warrant that work be expeditiously performed, the City of Carlsbad may utilize City employees or other personnel for the purpose of completing such work as soon as possible. The City of Carlsbad may request reimbursement for such work.

- K. Noise, Dust, and Debris - Each applicant must conduct and carry out all work in such manner as to avoid unnecessary inconvenience and annoyance to the public and occupants of neighboring property, as deemed by the City. The permittee must take appropriate measures to reduce, to the fullest extent practicable, noise, dust, litter and debris.

- L. Preservation of Monuments - Any monument set for the purpose of locating or preserving the lines of any street, property, subdivision, survey reference point, or permanent survey benchmark within the City may not be removed or disturbed, or caused to be removed or disturbed, without first obtaining permission in writing from the City of Carlsbad and the surveyor that set the monument, if possible. Permission to remove or disturb such monuments, reference points, or bench marks will be granted only upon condition that the person applying for such permission pay all expenses incident to the proper replacement of the monument. Monuments shall be replaced only by a registered land surveyor.

- M. Advance Notice of Improvements - Applicants should attempt to keep themselves informed of proposed street or sidewalk improvements in order that utilities may be installed prior to, or in conjunction with, making such improvements.

- N. Financial Guarantees – A financial guarantee covering required improvements may be required by the City. When required, the financial guarantee shall:
 - a. Run to the City of Carlsbad; and
 - b. Be in an amount equal to 100 percent of the cost, as estimated by the City, of any improvements which have not yet been constructed, installed and completed in compliance with City standards; and
 - c. Be with surety as approved by the City; and
 - d. Specify that all required improvements shall be completed within the period specified by the financial guarantee documents, construction

- contract documents or otherwise specified by the City; and
- e. Run until, and terminate ninety (90) days after, filing certification of completion and acceptance by the City of the “As-Builts”.

In the event that any or all of the required improvements are not completed within the time specified in the financial guarantee or construction contract documents, the City may let the contract to another contractor to complete the required work.

6. Infrastructure Checklist

The following check list shall be included with the test results, “as-built” drawings, (provided prior to acceptance sign-off), project certification, and the Engineers/Developers request for acceptance of the infrastructure improvements by the City:

- 1) Financial Guarantee/Bond: _____
(DATE FILED) (DATE RECEIVED)
- 2) Preconstruction conference: _____
(DATE)
- 3) Bacteriological analysis of water system: _____
(PASS DATE)
- 4) Hydrostatic test of water system: _____
(PASS DATE)
- 5) Water system inspection (lines, valves, curb stops, etc.): _____
(DATE)
- 6) Sewer system inspection (lamping of lines, manholes, etc.): _____
(DATE)
- 7) Street and/or alley inspection: _____
(DATE)
- 8) Fire Hydrant Flow Test: _____ (Flow test sheet on next page)
(PASS DATE)
- 9) Final inspection: _____
(PASS DATE)

ARTICLE 2
STANDARD SPECIFICATIONS FOR
STREETS AND STREET RELATED CONSTRUCTION

1. General

As previously noted, these specifications will be used in conjunction with the most current edition of the NMDOT Standard Specifications. Compliance with Article I - Policies and Specifications as well as any APWA Specifications is mandatory.

2. Street Classification and Geometric Design Standards

A. Existing streets are identified and classified on the “Functional Street Classification Map”. Contact the Planning, Engineering, and Regulation Department for a copy of this map. The Map may also be found at www.cityofcarlsbadnm.com/maps.cfm under the CARLSBAD COMMUNITY INFORMATION MAP. New streets shall be classified and existing streets may be reclassified by the City of Carlsbad, when warranted by street design, traffic volume, multi-modality or other criteria. Minimum street right-of-way widths are established by the City of Carlsbad Subdivision Ordinance (Ord. No. 2013-05).

Minimum street widths shall be as shown on the “Roadway Typical Sections for Streets” illustration in this article for Local, Major, Collector, Minor Arterial, Principle Arterial Streets. Examples for Local, Major Collector, Minor Arterial, Principle Arterial Streets, and Cul-de-sac street sections are available from the planning, Engineering, and Regulation Department or from the Public Works Department and must be submitted for approval by the City.

B. Cul-de-sac Geometric Standards

1. Cul-de-sacs will be required on all roadways that do not connect to an existing dedicated roadway. Right-of-Way shall be dedicated at the time of platting. The maximum length of a cul-de-sac is 800 feet and it shall be designed so that it cannot be extended in the future. Future extension may be approved by the City of Carlsbad after review by the Fire, Police, Utilities, Engineering and Planning Departments. The length of a cul-de-sac shall be

measured from the back of the nearest curb of the perpendicular street to the radius point in the middle of the cul-de-sac.

2. Minimum diameter:
 - a. Right-of-way - 100 feet with no on-street parking.
 - b. Pavement (in bulb back-to-back of curb) - 80 feet
 - c. Center island (if any) - 20 feet with no on-street parking.
 - d. Geometry must be approved by the City Fire Marshall.

3. *Pavement Design Standards*

- A. Typical pavement sections for street construction in the City of Carlsbad shall be designed in accordance with the latest edition of the AASHTO “Guide for the Design of Pavement Structures”, except as noted below. The design shall be performed by a Licensed Professional Engineer registered in the State of New Mexico.
- B. Local streets may use the design shown in the “Roadway Typical Section for Local Streets” attached herein.
- C. Laboratory analysis of the subgrade soils underneath the street is first required for pavement design. The rest of the design process is as follows:
 1. For streets in the City of Carlsbad, the Pavement Design Parameters shown in Table II have been established for arterial, collector, and minor street classifications. These parameters were used to develop the Structural Numbers (SN) shown in Table III.
 2. Laboratory analysis of the subgrade soils at the street location will yield an “R-Value” for the soil. Using this “R-Value” and Table III, a Structural Number (SN) can then be selected for the appropriate classification of street to be designed.
 3. Trial pavement sections can then be analyzed, using the coefficients from Table IV, to meet the minimum SN value required by Table III, as illustrated in the following example:

Pavement Design Example:

Design a Pavement Section for an arterial street to be constructed in a soil with R-Value of 30:

1. From Table III, for an R-Value of 30, a Structural Number (SN) of 3.35 is

required for the typical section.

- Using the coefficients from Table IV, try the following trial section:

$$\begin{aligned}
 6'' \text{ HMA (Coeff = 0.40)} &= 6'' \times 0.40 = 2.40 \\
 8'' \text{ Untreated Base Course (Coeff = 0.10)} &= 8'' \times 0.10 = 0.80 \\
 & \text{SN} = 3.20
 \end{aligned}$$

< 3.35 N.G. (Does not meet specifications. Try increasing HMA thickness to 6½")

$$\begin{aligned}
 6\frac{1}{2}'' \text{ HMA} &= 6.5'' \\
 & \times 0.40 \\
 & = 2.60 \\
 8'' \text{ Untreated Base Course} &= 8'' \\
 & \times 0.10 \\
 & = 0.80
 \end{aligned}$$

$$\text{SN} = 3.40 > 3.35 \text{ OK}$$

- In no case, however, shall the street pavement section be less than 2" HMA over 4" base course the minimum thicknesses shown on the Standard Drawings.
- An engineering report of the soils evaluation and pavement design calculations shall accompany the construction drawings that shall be submitted to the City of Carlsbad for review.

TABLE II: PAVEMENT DESIGN PARAMETERS

Street Type	Traffic Load (ESAL)		Serviceability Index	Regional Factor
	HMA	Concrete		
Arterial Street	200	130	2.5	1.0
Collector Street	70	40	2.0	1.0
Residential Street	10	6	1.5	1.0

**TABLE III: STRUCTURAL NUMBER (SN) RELATIVE TO R-VALUE
(HOT MIX ASPHALT PAVEMENT)**

R-Value*	Structural Number			
	Arterial Street	Collector Street	Minor Street	
16	3.80	3.10	2.30	* R-Values are determined per NMSHTD Bulletin No. 102 using the AASHTO soil classification, gradation, and P.I. Values. Any soils with an R-value of less than 16 must be removed to a point two (2) feet below top of pavement.
18	3.80	3.05	2.25	
20	3.75	3.00	2.20	
22	3.65	2.95	2.15	
24	3.55	2.85	2.10	
26	3.50	2.80	2.05	
28	3.40	2.75	2.00	
30	3.35	2.65	1.90	
32	3.25	2.60	1.90	
34	3.20	2.55	1.85	
36	3.10	2.50	1.80	
38	3.05	2.40	1.80	
40	3.00	2.35	1.80	
42	3.00	2.30	1.80	
44	3.00	2.25	1.80	
46	3.00	2.20	1.80	
48	3.00	2.20	1.80	
50	3.00	2.20	1.80	
52	3.00	2.20	1.80	
54	3.00	2.20	1.80	
56	3.00	2.20	1.80	
58	3.00	2.20	1.80	
60	3.00	2.20	1.80	
62	3.00	2.20	1.80	
64	3.00	2.20	1.80	
66	3.00	2.20	1.80	
68	3.00	2.20	1.80	
70	3.00	2.20	1.80	
72	3.00	2.20	1.80	
74	3.00	2.20	1.80	
76	3.00	2.20	1.80	
78	3.00	2.20	1.80	
80	3.00	2.20	1.80	

TABLE IV: COEFFICIENTS (C) OF PAVEMENT MATERIALS

MATERIAL	COEFFICIENT
Concrete Pavement	0.50
Hot Mix Asphalt Pavement	0.40*
Hot Mix Seal Coat	0
Untreated Base Course	0.10
Bituminous Treated Base Course	(See Note 1)
Cement Treated Base Course	(See Note 2)
Lime Treated Subgrade	(See Note 2)
Cement Treated Subgrade	(See Note 2)

Note 1: Coefficients vary based on Marshall Stability of design mix.

Note 2: Coefficients vary based on Compressive Strength of design mix.

* Based on minimum Marshall Stability of 1640.

A **Pavement Mix Design** shall be used on all City roadways and shall be developed by a NMDOT approved testing Laboratory, reviewed and signed by a Professional Engineer registered in the State of New Mexico. The Mix Design shall be submitted to the City of Carlsbad for approval prior to any paving operations.

4. Engineering Data

If not previously approved by the City, plans and profiles, drainage reports and utility reports prepared by a Licensed Professional Engineer registered in the State of New Mexico, shall be submitted to and approved by the City of Carlsbad. In all cases these reports and plans shall be submitted prior to the issuance of any permit. Approval is required prior to performing any work.

- A. Grades - The grades of all streets shall be a minimum of 0.30% except where topographical conditions unquestionably justify a departure from the minimum. Crown slopes shall be a minimum of 2.0%.

Street construction drawings shall be submitted, and shall contain a complete plan and profile exhibiting all existing grades, proposed grades, and elevations and grades of proposed connection to existing streets.

Two (2) hard copies, one (1) PDF file, and one (CAD) file reproducible as-built copy of the approved prints shall be submitted to the Planning, Engineering and Regulation Department of the City of Carlsbad upon completion of construction.

- B. Drainage Report - A storm drainage report prepared by a Licensed Professional Engineer registered in the State of New Mexico, shall be submitted to the City of Carlsbad. The report shall be prepared in accordance with Article 15 of these Specifications.
- C. Utility Report - In all cases, all existing utilities, as well as the location of all proposed utilities, shall be illustrated. For all existing utilities, locations shall be noted as well as their elevations with respect to the proposed streets. In the case of proposed utilities all locations shall be illustrated with proposed elevations and grades. All utilities in/or crossing any proposed street shall be installed prior to the preparation of the subgrade for street construction.
- D. Traffic Report – The City Engineer may require that traffic impact analyses be performed for any or all commercial and residential developments. Traffic impact analyses shall be signed by a Licensed Professional Engineer registered in the State of New Mexico. All properties fronting on State highways require separate permits from the NMDOT. A copy of the approved permit shall be submitted to the City of Carlsbad prior to the start of any construction.

5. *Roadway Construction Specifications*

All streets shall be built in accordance with the 2019 Edition or most current edition of the NMDOT Standard Specifications, or the New Mexico Standard Specifications for Public Works Construction, 2006 Edition, NMAPWA. (NMSSPWC), except as modified by these Public Infrastructure Specifications.

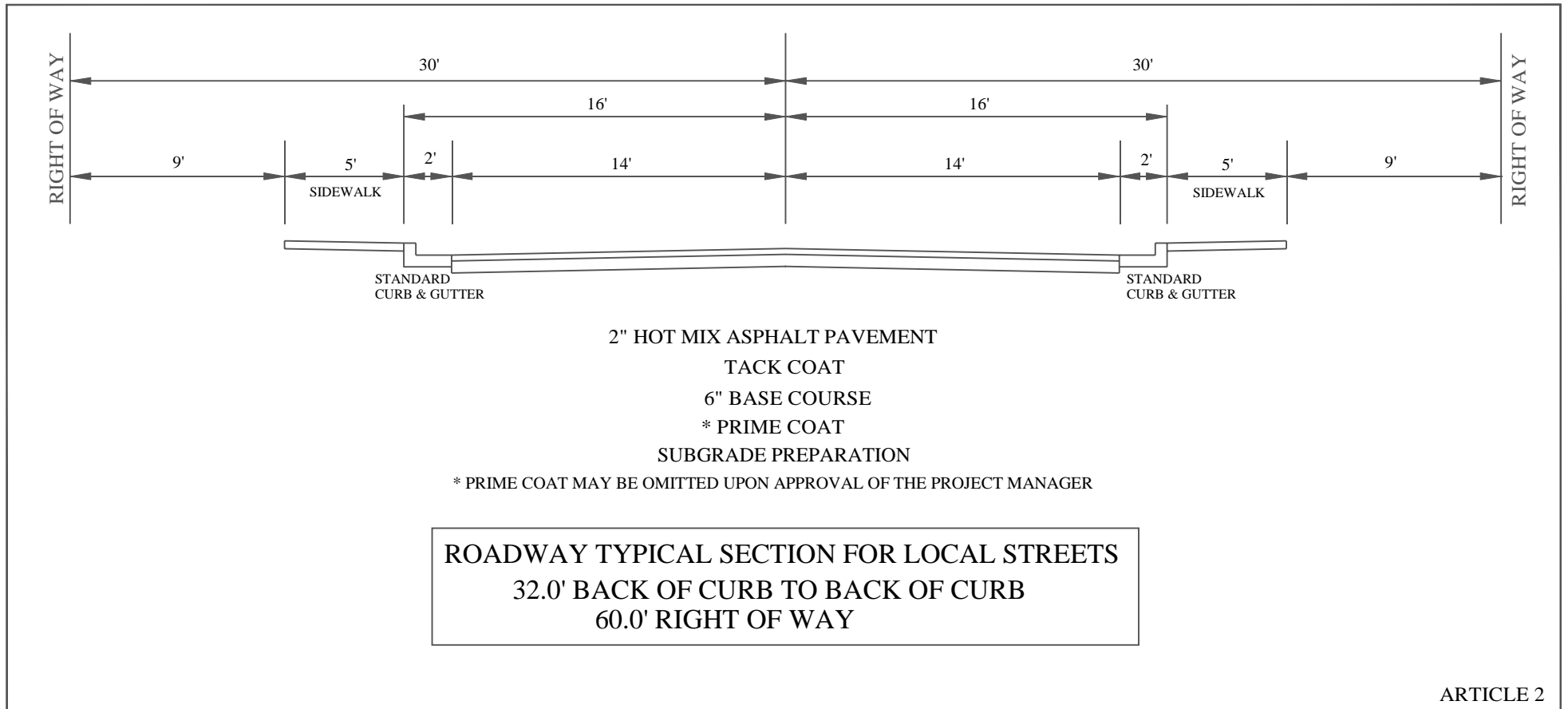

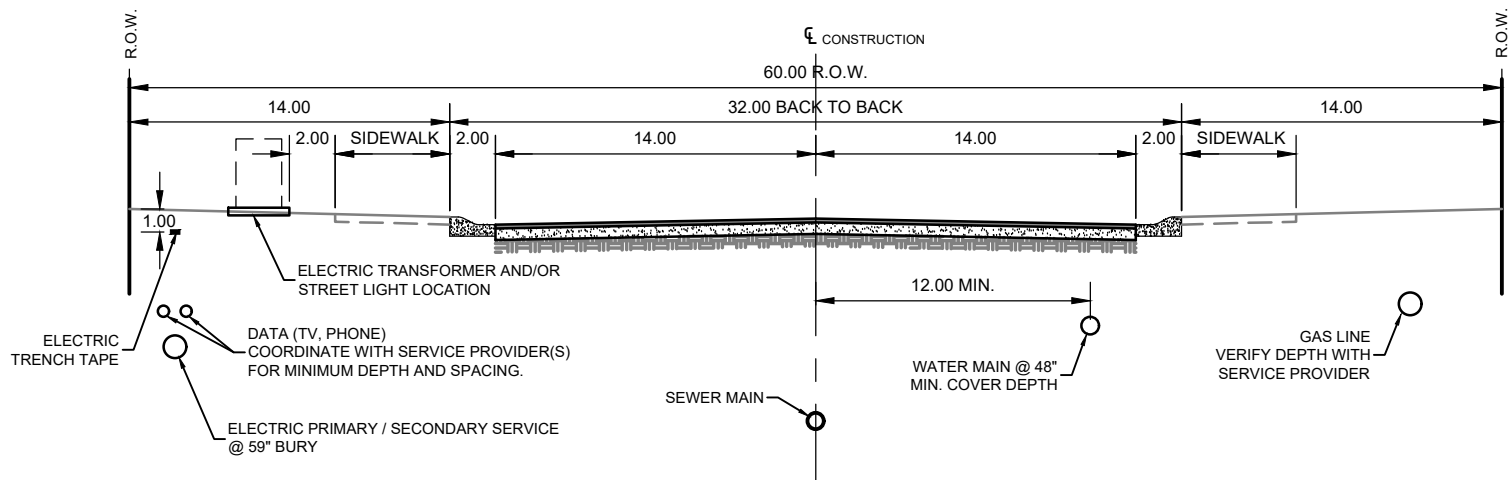
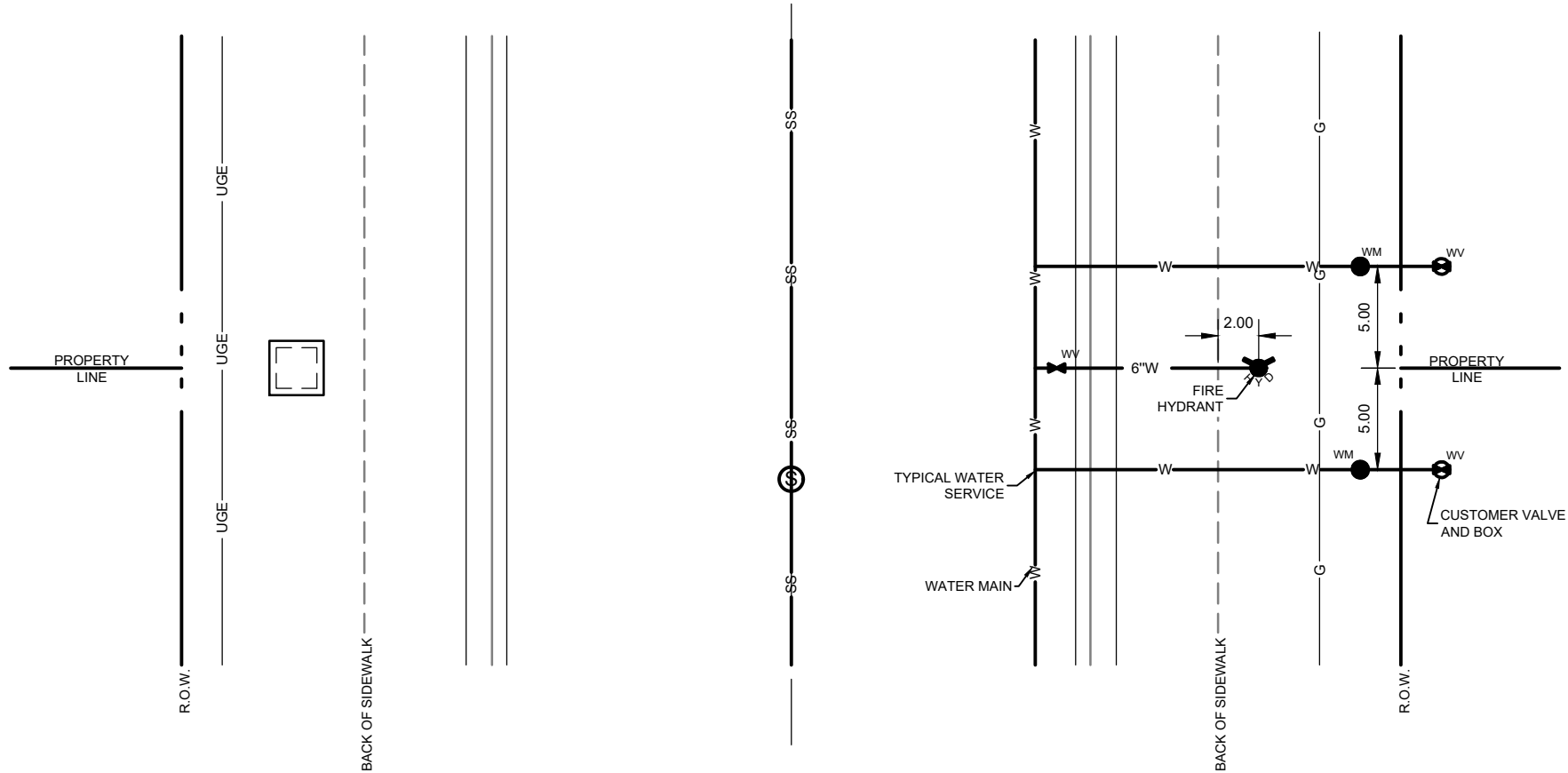

TYPICAL UTILITY LAYOUT

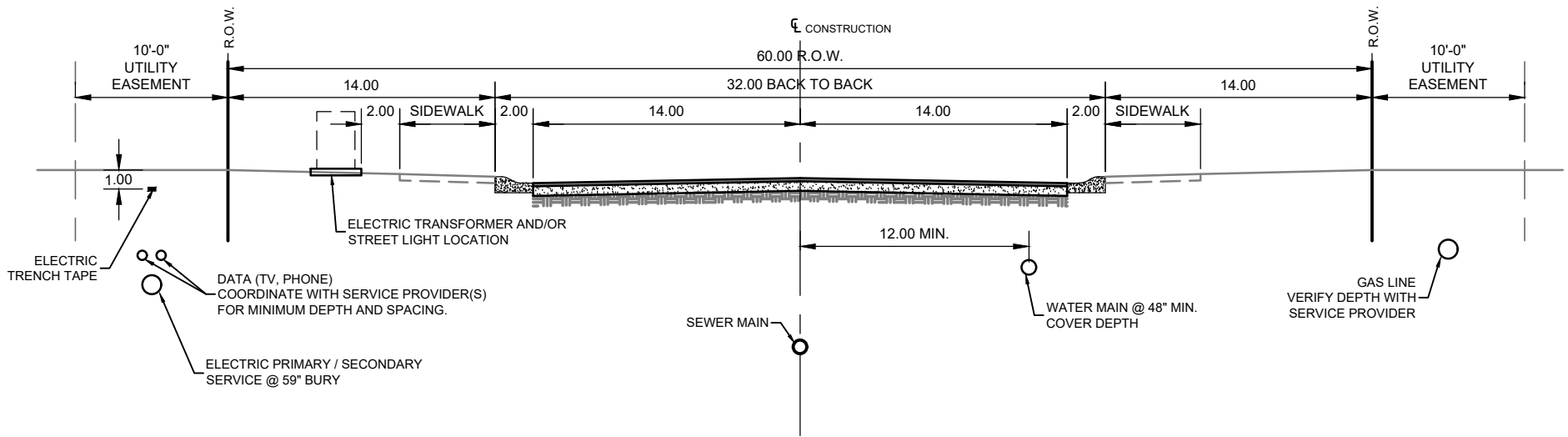
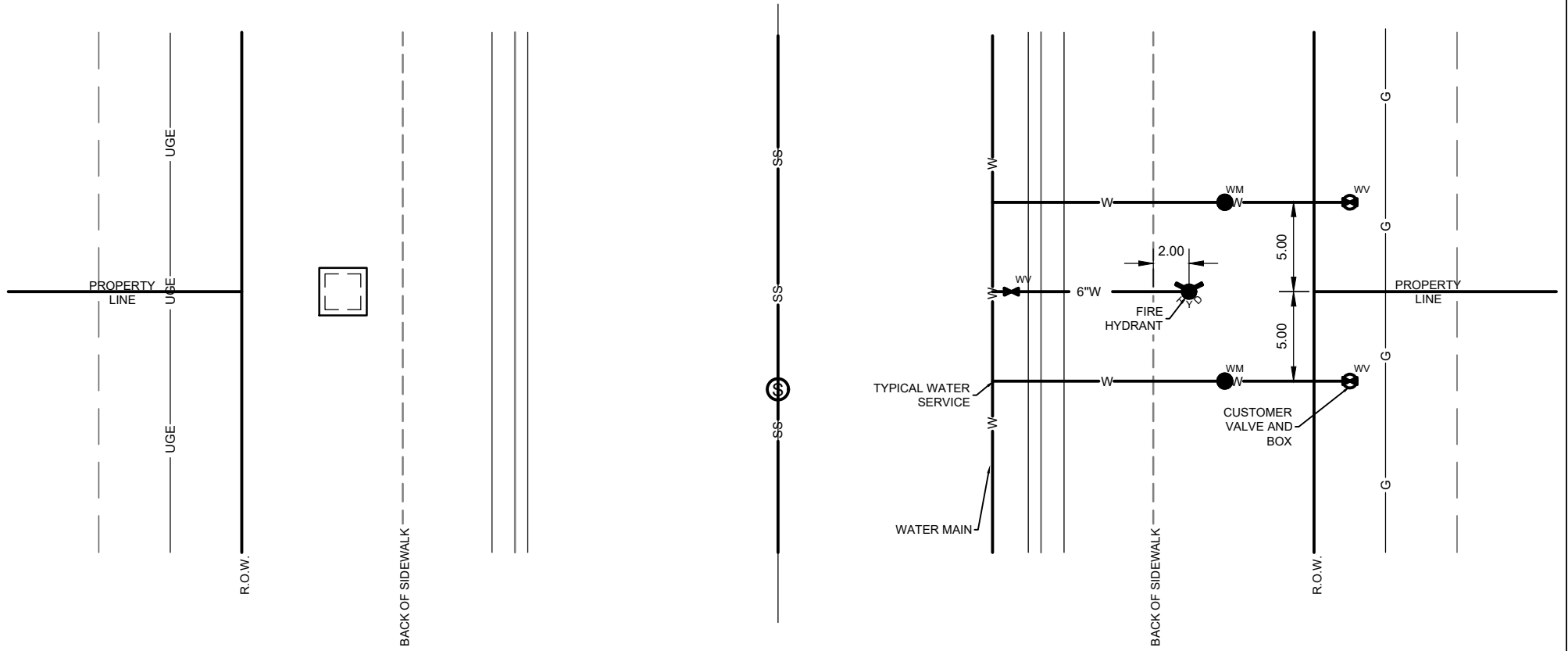

TYPICAL UTILITY LAYOUT WITH EASEMENT

ARTICLE 3
STANDARD SPECIFICATION FOR EXCAVATION
UNDER PAVED STREETS AND ALLEYS

1. General

This section addresses excavation, trenching, and backfilling under paved streets and alleys in the City of Carlsbad. The construction and materials shall conform to the NMSSPWC Standard Specifications, Section 701, except as modified herein.

Compliance with Article 1 – General Statement of Policies and Specifications of these specifications is mandatory. As stated in Article 1, Encroachment Permits are required before any excavation can begin. Only in the case of an emergency may an excavation be made without a permit. However, the person performing the excavation will have to apply for a permit and pay the appropriate fees on the next working day following the emergency excavation. All excavation and trenching shall meet OSHA requirements. Any alley used to convey storm flows or used for commercial use, must be paved.

2. Provisions for Excavation

A. Engineering Data - Prior to the issuance of an Encroachment Permit, the applicant shall provide an illustration showing the exact location of the excavation, the extent of the excavation, and a traffic control plan. The Contractor shall be responsible for locating any underground utilities and for any damage resulting thereto.

3. Specification for Excavation and Backfill

A. Breaking through Pavement

1. Heavy duty pavement breakers may be prohibited when the use endangers existing structures or other property.
2. Saw cutting or other neat line cutting of the existing pavement is required.
3. Sections of sidewalks are to be removed to the nearest score line or saw cut edge.
4. Unstable pavement must be removed over cave-ins or over-breaks, and the subgrade is to be treated in the same manner as the main excavation.
5. Pavement edges must be trimmed to a vertical face and neatly aligned with the center line of any trench.
6. The applicant is not required to repair damage existing prior to excavation unless his cuts leave small floating sections that may be unstable, in which case the applicant must remove such sections and backfill such area as well as the area of the excavation.

- B. Care of Excavated Material - All material excavated and piled adjacent to the excavation or in any public place must be so piled and maintained as not to endanger the public and those working in the excavation, and as to cause as little inconvenience as reasonably possible to vehicle and pedestrian traffic. Excavated material may not be used as a barricade. In order to expedite the flow of traffic or to keep dirt and dust from spreading or flying, the applicant may be required to use guards or other devices.
- C. Backfilling - Any person who trenches or excavates on or within a public right-of-way for any purpose whatsoever is required to backfill the trench or excavation as follows:
1. Flow fill may be used in all trenches lying below a paved street or paved alley surface. The flow fill shall be from an approved commercial source. Flow fill shall be placed in no more than a four (4) foot lifts every 24 hours.
 2. If flow fill is not utilized, backfill material must be an "Engineered Backfill" with an approved Proctor data sheet. Each layer or lift is to be placed evenly, level, and of such a depth that the degree of compaction as required herein may be obtained throughout the entire backfill without exceeding the depth of layer or lift as recommended by the manufacturer of the compaction equipment being used for various soil types encountered or as determined by actual compaction tests of the lift or layer in place. In no case is the method of compaction being used to cause damage to the pipe line or other subsurface structures in the trench, excavation, or adjacent thereto.
 3. Each lift or layer must be sufficiently moistened to permit good compaction but not sufficient to cause the backfill material to lump or form a muddy ball when squeezed. Moistening water is to be added only in amount required to achieve optimum moisture content for the type of soil encountered, and must be thoroughly worked into the backfill material before compaction.
 4. The backfill material must be thoroughly compacted to a minimum of 100 (%) percent of maximum density throughout the entire depth of the excavation as determined by the Proctor Method, AASHTO T-99. The moisture content of the backfill material in place must not exceed the optimum nor be less than the optimum minus five percent. The obtaining of the correct moisture content is the responsibility of the person doing the trench or excavation backfill. Moisture and density requirements are governed by AASHTO Designation: T-99, including all revisions thereof.

5. When an excavation has been cut through existing pavement, the temporary pavement patch shall provide a level and safe riding surface until the permanent pavement patch can be placed.
6. Backfill and compaction inspection must be made as required by the City of Carlsbad. The City of Carlsbad is authorized to require backfill moisture density tests for the purpose of determining compliance with the compaction requirements of this section. Such tests are to be made in accordance with the procedures contained in AASHTO Designation No. T- 99, including all revisions thereof, and all costs connected with this testing will be at the expense of the person doing the actual backfill and compaction work.
7. In the event the complete backfill fails to meet the density requirements of this section when tested, or otherwise fails as evidenced by settlement of the trenches or excavation, the City of Carlsbad may order the faulty backfill material removed, replaced, and re-compacted to the required density specified herein, and order the replacement of all pavement destroyed or damaged as the result of the backfill failure settlement. The backfill warranty shall be guaranteed for five (5) years and all testing shall be submitted to the City of Carlsbad for acceptance.
8. All soil bedding materials used should be non-plastic. Backfill materials may be native soils, however, no material having a maximum individual particle size or agglomeration clod size greater than two and one-half (2 ½) inches shall be placed within twelve (12) inches of utility piping installed and no material larger than six (6) inches in the final backfill zone.
9. In the event an applicant fails to comply with the requirements of this section the City of Carlsbad may refuse to permit such applicant to thereafter engage in trenching or excavation. The warranty of asphalt pavement shall be guaranteed for one (1) year.

D. Restoration of Surface

1. Upon completion of the backfilling of any excavation, and before resurfacing, the permittee must notify the City of Carlsbad. Placement and the cost of resurfacing will be borne by the applicant. The applicant must keep each excavation safe for pedestrian and vehicular traffic. Applicant will resurface the trench within 3 days of approval by the City of Carlsbad.
2. Acceptance or approval of excavation work or backfilling does not prevent the City from asserting a claim against the applicant for incomplete or defective work if discovered within one year from the completion of the project.

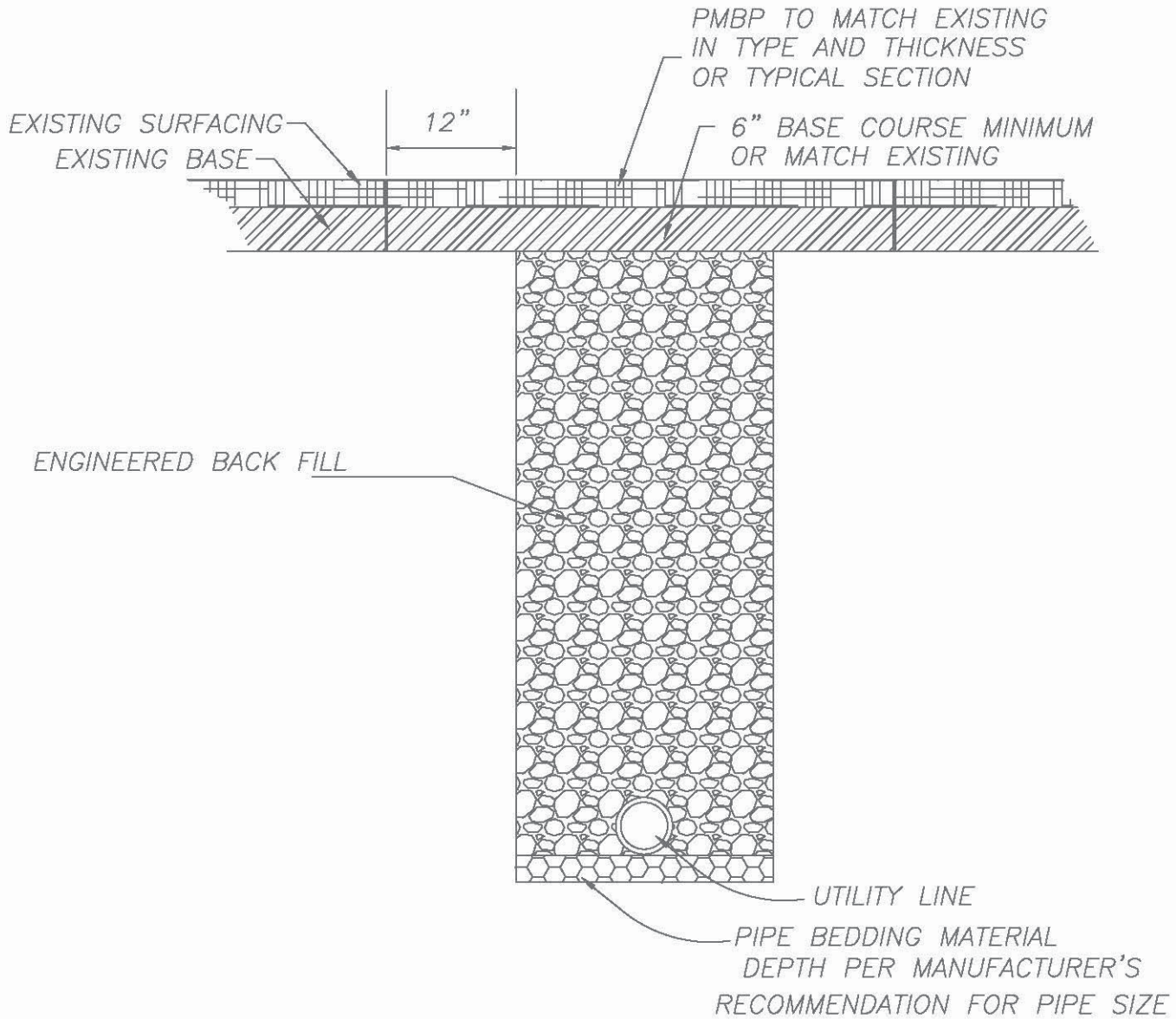

FINISHED MAT OF PMBP TO HAVE A SMOOTHNESS OF 1/2 INCH
WHEN USING A 10 FOOT STRAIGHT EDGE IN ANY DIRECTION

TYPICAL ENGR. FILL TRENCH DETAIL

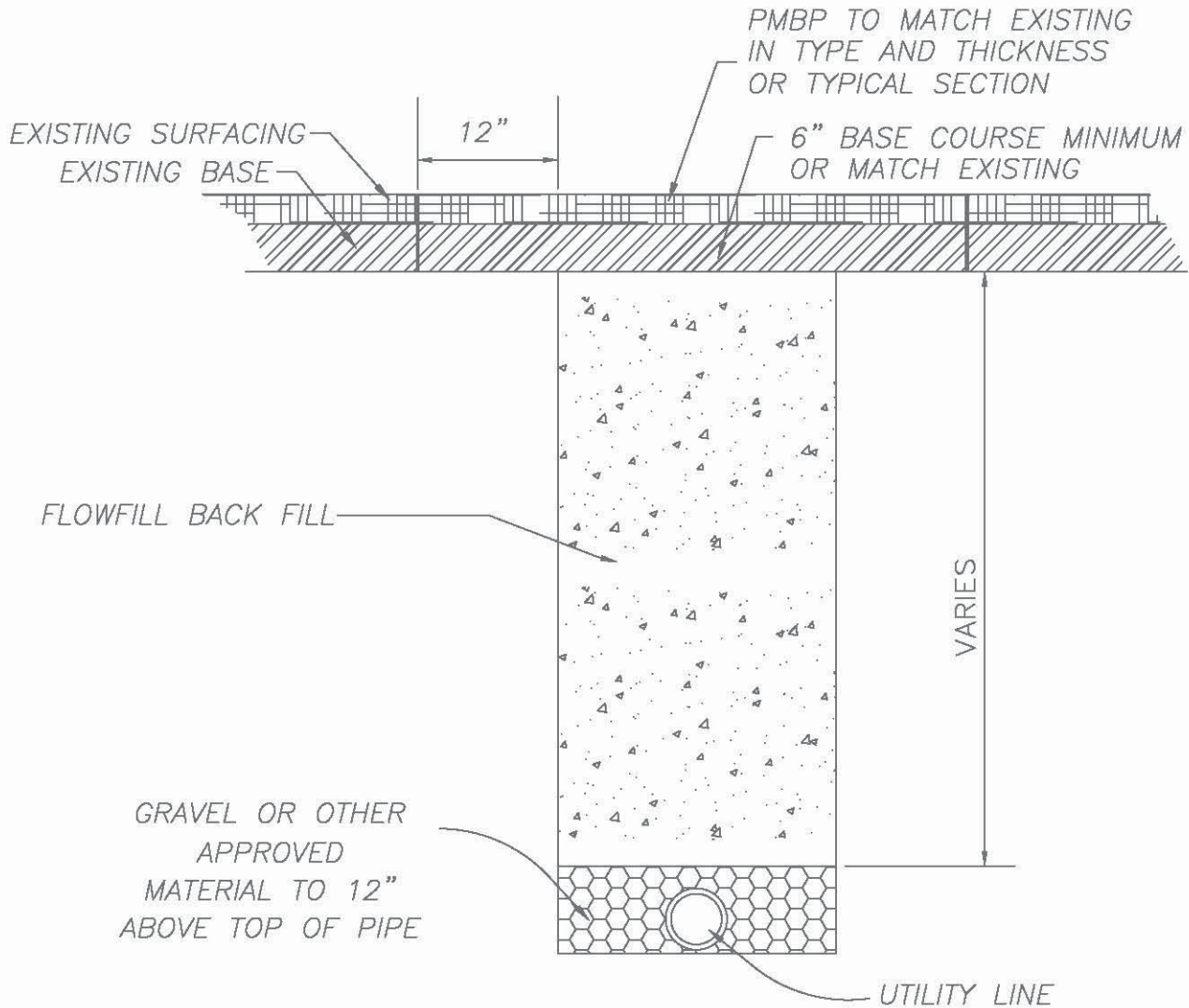

FINISHED MAT OF PMBP TO HAVE A SMOOTHNESS OF 1/2 INCH
WHEN USING A 10 FOOT STRAIGHT EDGE IN ANY DIRECTION

TYPICAL FLOWFILL TRENCH DETAIL

ARTICLE 4
STANDARD SPECIFICATION FOR EXCAVATION
NOT UNDER PAVED STREETS OR ALLEYS

1. General

This section addresses excavation, trenching, and backfilling **not** under paved streets and alleys in the City of Carlsbad. The construction and materials shall conform to the NMSSPWC Standard Specifications, Section 701, except as modified herein.

Compliance with Article I – General Statement of Policies and Specifications of these specifications is mandatory. As stated in Section I, Encroachment Permits are required before any excavation can begin. Only in the case of an emergency may an excavation be made without a permit. However, the person performing the excavation will have to apply for a permit and pay the appropriate fees on the next working day following the emergency excavation. All excavation and trenching shall meet OSHA requirements.

This work shall consist of excavation of the trench and the backfilling of the trench for all pipe lines, cables, conduits and appurtenances, in substantial compliance with the specifications and drawings. The work and materials shall conform to the Standard Specifications.

2. Provisions for Excavation

A. Engineering Data - Prior to the issuance of an Encroachment Permit, the applicant shall provide an illustration showing the exact location of the excavation, the extent of the excavation, and a traffic control plan. The Contractor shall be responsible for locating any underground utilities and for any damage resulting thereto.

3. Specification for Excavation and Backfill

A. Care of Excavated Material - All material excavated and piled adjacent to the excavation or in any public place must be so piled and maintained as not to endanger the public and those working in the excavation, and as to cause as little inconvenience as reasonably possible to vehicle and pedestrian traffic. Excavated material may not be used as a barricade. In order to expedite the flow of traffic or to keep dirt and dust from spreading or flying, the applicant may be required to use guards or other devices. All backfill material must have an approved Proctor data sheet.

B. Backfilling - Any person who trenches or excavates on or within a public right-of-way for any purpose whatsoever is required to backfill the trench or excavation as follows:

1. Flow fill may be used in all trenches lying below a paved street or paved alley surface. The flow fill shall be from an approved commercial source. Flow Fill shall be placed in no more than a four (4) foot lift every 24 hours.
2. If flow fill is not utilized, backfill material must be an "Engineered Backfill" with an approved Proctor data sheet. Each layer or lift is to be placed evenly, level, and of such a depth that the degree of compaction as required herein may be obtained throughout the entire backfill without exceeding the depth of layer or lift as recommended by the manufacturer of the compaction equipment being used for various soil types encountered or as determined by actual compaction tests of the lift or layer in place. In no case is the method of compaction being used to cause damage to the pipe line or other subsurface structures in the trench, excavation, or adjacent thereto.
3. Each lift or layer must be sufficiently moistened to permit good compaction but not sufficient to cause the backfill material to lump or form a muddy ball when squeezed. Moistening water is to be added only in amount required to achieve optimum moisture content for the type of soil encountered, and must be thoroughly worked into the backfill material before compaction.
4. The backfill material must be thoroughly compacted to a minimum of 100 (%) percent of maximum density throughout the entire depth of the excavation as determined by the Proctor Method, AASHTO T-99. The moisture content of the backfill material in place must not exceed the optimum nor be less than the optimum minus five percent. The obtaining of the correct moisture content is the responsibility of the person doing the trench or excavation backfill. Moisture and density requirements are governed by AASHTO Designation: T-99, including all revisions thereof.
5. Backfill and compaction inspection must be made as required by the City of Carlsbad. The City of Carlsbad is authorized to require backfill moisture density tests for the purpose of determining compliance with the compaction requirements of this section. Such tests are to be made in accordance with the procedures contained in AASHTO Designation No. T- 99, including all revisions thereof, and all costs connected with this testing will be at the expense of the person doing the actual backfill and compaction work.
6. In the event the complete backfill fails to meet the density requirements of this section when tested, or otherwise fails as evidenced by settlement of the trenches or excavation, the City of Carlsbad may order the faulty backfill

material removed, replaced, and re-compacted to the required density specified herein, and order the replacement of all pavement destroyed or damaged as the result of the backfill failure settlement. The backfill warranty shall be guaranteed for five (5) years and all testing shall be submitted to the City of Carlsbad for acceptance.

7. In the event an applicant fails to comply with the requirements of this section the City of Carlsbad may refuse to permit such applicant to thereafter engage in trenching or excavation.
8. All soil bedding materials used should be non-plastic. Backfill materials may be native soils, however, no material having a maximum individual particle size or agglomeration clod size greater than two and one-half (2 ½) inches shall be placed within twelve (12) inches of utility piping installed and no material larger than six (6) inches in the final backfill zone.

C. Restoration of Surface

1. Upon completion of the backfilling of any excavation, and before resurfacing, the permittee must notify the City of Carlsbad. Placement and the cost of resurfacing will be borne by the applicant. The applicant must keep each excavation safe for pedestrian and vehicular traffic. Applicant will resurface the trench within 3 days of approval by the City of Carlsbad.
2. Acceptance or approval of excavation work or backfilling does not prevent the City from asserting a claim against the applicant for incomplete or defective work if discovered within one year from the completion of the project.

GENERAL UTILITY CONSTRUCTION NOTES

1. BELL HOLES AT JOINTS SHALL BE HAND EXCAVATED TO PROVIDE AMPLE ROOM TO PROPERLY MAKE UP THE JOINT, BUT IN NO CASE SHALL THERE BE MORE THAN 9" OF UNSUPPORTED LENGTH AT EITHER END OF EACH LENGTH OF PIPE.
2. BOTTOM OF TRENCH IS TO BE EXCAVATED TO A SMOOTH, UNIFORM GRADE AND HAND LEVELLED, IF NECESSARY, TO SECURE AN EVEN BEARING SURFACE FOR THE PIPE.
3. TYPE I BACKFILL SHALL BE IMPORTED MATERIAL OR SOILS TAKEN FROM SPOIL BANK WHICH ARE FREE OF RUBBLE AND ORGANIC MATERIAL AND WHERE NO MATERIAL IS GREATER THAN ONE-QUARTER INCH IN DIAMETER. TYPE I BACKFILL SHALL BE COMPACTED TO 95% MAXIMUM DENSITY PER AASHTO T-99.
4. TYPE II BACKFILL SHALL BE TAKEN FROM SPOIL BANK, IF FREE OF RUBBLE AND ORGANIC MATERIAL, AND COMPACTED TO 95% MAXIMUM DENSITY PER AASHTO T-99

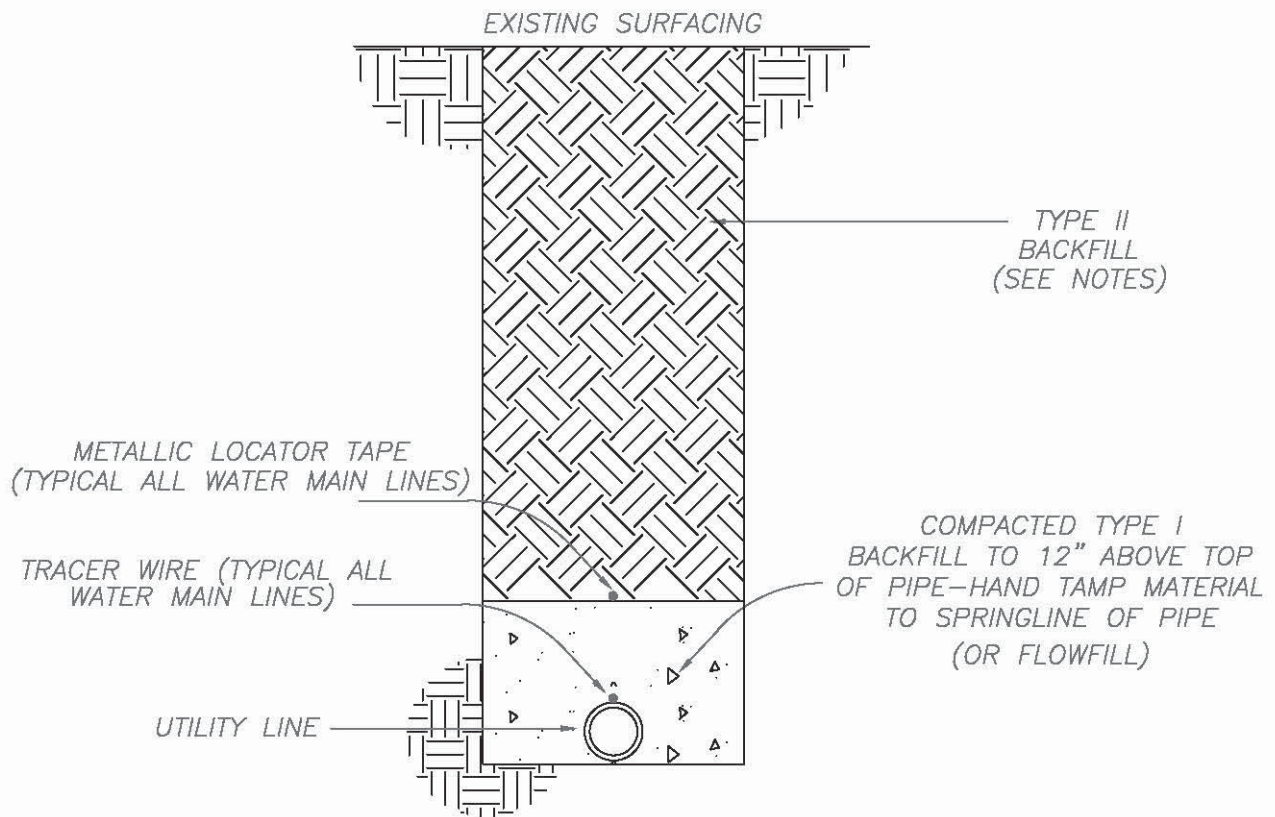

TYPICAL BACKFILL & TRENCH DETAILS

NON PAVED ROADS AND ALLEYS

ARTICLE 5
STANDARD SPECIFICATION
FOR THE CONSTRUCTION OF ALLEYS

1. General

Alleys are considered public rights-of-way, used primarily for public utility provision. The following specifications shall govern the construction and/or alteration of alleys within the City of Carlsbad. In addition, all definitions and requirements regarding alleys, as stipulated in the Subdivision Ordinance, shall also apply. Compliance with Article 1 – General Statement of Policies and Specifications of these specifications is mandatory.

2. Alley Widths

- A. The alley width shall be measured between the property lines of the abutting properties and shall be a minimum of twenty-feet (20') in width in residential, commercial and industrially-zoned areas.
- B. Minimum alley widths shall be maintained at all times. In instances where wider alleys are necessary, the full width shall be maintained at all times. The location and widths of alleys shall be illustrated on all subdivision plats.

3. Engineering Data

- A. Grade, Drainage, & Utility Report - All stipulations of Section IV, Article II - Engineering Data, as listed under the Standard Specifications for Streets and Street Related Construction, shall apply to this section. The following requirements shall also apply:
 - 1. Use of inverted crown - Inverted crowns will be required in all paved alleys. In cases where inverted crown construction is impossible, a regular crown section will be allowed. In no instance will drainage be designed to flow onto private property. All grades and drainage shall be designed in such a way as to insure complete drainage from private yard to alley and alley to street. In the case of unpaved alleys, a regular crown section will be required. Paved alleys with a minimum grade of less than 0.30% shall have a valley gutter.
 - 2. Paving of alleys – Alleys may have an asphalt or concrete driving surface but shall, at a minimum, have a six-inch (6") thick base course surface from edge of right-of-way to edge of right-of-way. In all cases, an alley to be paved shall be paved for its entire block length. In no case will a part or

section of an alley be paved where other sections are left unpaved.

3. All alleys in commercial and industrially-zoned areas and any alleys used for drainage ways shall be paved.

4. *Standard Specifications*

A. All alleys shall be built in accordance with the following Standard Specifications:

1. Alley Entrances - A drive entrance (alley pad) will be required at the entrance or exit of all alleys and shall conform to the typical details as illustrated. Due to difficult or unusual site conditions, the engineer or developer may submit a different detail for approval by the City Engineer. All alley pads shall be 8" thick, 3000 PSI concrete.
3. All alley pads and access across alleys shall meet all ADA accessibility requirements.
4. Where sidewalks exist or are required with new development, the sidewalk shall extend across the alley, considered part of the alley pad.
5. If a new subdivision adjoins (abuts) a previously developed alley that does not have alley pads or sidewalks, the new development shall add an alley pad or sidewalk in those adjoining alleys.

B. Typical Sections

Typical sections for alley construction shall be as illustrated in the Standard Details for Alley Construction. Other layouts may be submitted to the City of Carlsbad for approval.

UNPAVED ALLEY

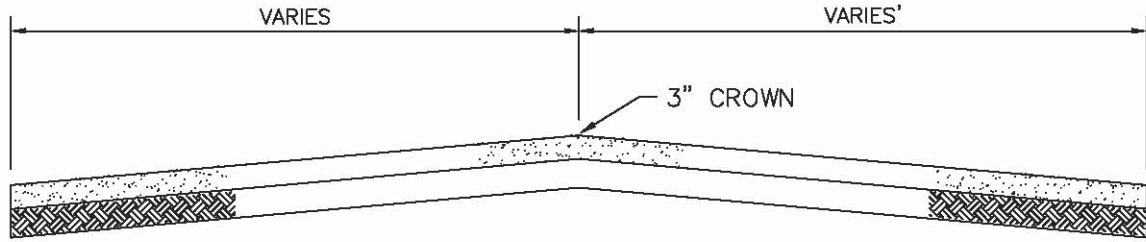

6" II-B BASE COURSE AT 96% AASHTO T 180
SUBGRADE PREP. AT 100% AASHTO T 99

PAVED ALLEY (INVERT SECTION)

ALLEY SLOPE GREATER THAN 0.30%

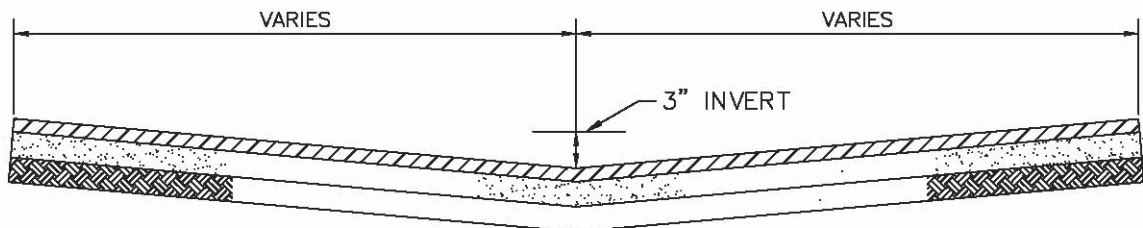

2" P.M.B.P. I-B AT 92%-96% MAX. DENSITY
6" II-B BASE COURSE AT 96% AASHTO T 180
SUBGRADE PREP. AT 100% AASHTO T 99

PAVED ALLEY (VALLEY GUTTER SECTION)

ALLEY SLOPE LESS THAN 0.30%

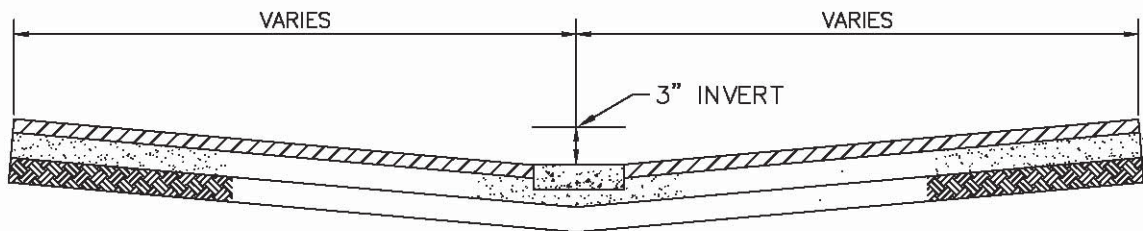

2" P.M.B.P. I-B AT 92%-96% MAX. DENSITY
6" II-B BASE COURSE AT 96% AASHTO T 180
SUBGRADE PREP. AT 100% AASHTO T 99
6" x 24" VALLEY GUTTER

ALLEY DETAILS

ARTICLE 6
STANDARD SPECIFICATIONS
FOR SIDEWALK, FILLET AND DRIVEPAD CONSTRUCTION

1. General

This Section addresses the placement, replacement and/or removal of sidewalks, fillets and drivepads within the public rights-of-way of the City of Carlsbad. Subgrade preparation, placement of sidewalk, fillets and drivepads, location of sidewalks, fillets, and drivepads, and grades for sidewalks, fillets and drivepads shall be as described below. Compliance with Article I – General Statement of Policies and Specifications of these specifications is mandatory. All construction shall meet or exceed American Disabilities Act (ADA) requirements.

2. Policies Regarding Sidewalk and Drivepad Construction

A. Engineering Requirements - Accompanying all applications for sidewalk, fillet and drivepad construction shall be an engineering plan. The City of Carlsbad may require that the plan illustrate existing and proposed grades of the curb and gutter and streets. No permits for construction shall be issued until such information has been provided and approved by the City Engineer.

3. Standard Specification for Placement of Sidewalk

A. Location - All sidewalks shall be located per the Subdivision Ordinance, which states:

1. Residential lots within the city-limits regardless of size, and residential lots outside the city limits of one-half acre or less in size, shall have concrete sidewalks a minimum of Five (5) feet wide and four inches thick (See Illustration 10). Sidewalks shall be placed directly adjacent to the back of curb and gutter or directly adjacent to the property line within the right-of-way and the location of sidewalks shall be consistent within the proposed development. Where a variance is approved from the required provision of sidewalks, an ADA compliant, alternative route to the nearest bus stop or school is required.
2. Commercial lots shall have sidewalks a minimum of Five (5) feet wide and four inches thick within, or adjacent to, the right-of-way or within, or adjacent to, the property line where pedestrian activity is planned.

Corners of sidewalks shall be constructed to meet ADA standards and sidewalks at street intersections shall have ADA compliant ramps and crosswalks. Sidewalks shall be constructed at the time of development and cracked sidewalks shall be replaced prior to issuance of a Certificate of Occupancy. Where a variance is approved from the required provision of sidewalks, an ADA compliant, alternative route is required.

3. If drive pads will not be installed because mountable curb is used then the sidewalk thickness shall be increased to six inches (6") thick for the entire length of sidewalk.

- B. Grades for Sidewalks - All sidewalks shall slope 1/4" for each foot of width. The sidewalk shall slope toward the street. Sidewalks shall be constructed at an elevation of 1/4" (1:50 cross slope) vertically for each foot of sidewalk as illustrated on the details. This stipulation may be waived by the City of Carlsbad in areas where topographical features will not allow for such slopes.
- C. If an obstruction is located in the sidewalk, (utility pole, mailbox, etc.) a minimum 4' clearance must be maintained at the obstruction along the sidewalk and conform to all current ADA standards.
- D. All concrete sidewalks, drivepads, fillets, etc. must be protected from freezing for a minimum of four (4) days.
- E. Developments on corner lots shall be required to construct or reconstruct existing fillets and sidewalks to comply with ADA requirements.
- F. Any sidewalk or other pedestrian pathway removed for any reason, shall be replaced with an ADA approved surface within fourteen (14) calendar days, unless otherwise approved by the City of Carlsbad.
- G. During sidewalk construction or reconstruction, signage shall be provided to direct pedestrians to the nearest open sidewalk.

4. *Standard Specifications for Placement of Drivepads*

- A. Location - All drivepads shall be located per the this Document, which states:
 - 1. Drivepads shall be constructed for all residential and commercial development. All drivepads shall meet ADA standards, including 1:48 cross slope and 1:20 running slope in direction of travel. The drivepad must rise to the level of the top of the curb before tying into existing

grades, which forces storm water to remain in the roadway.

- a. Residential development – driveways shall be paved with reinforced concrete a minimum of six inches thick or asphalt a minimum of four inches thick and shall be a minimum of twelve (12) feet wide.
 - b. Commercial Development - driveways shall be a minimum of twenty- four (24) feet wide and a maximum of forty (40) feet long and a minimum of six inches thick for reinforced concrete or four inches thick for asphalt. Main access points for shopping centers shall be a minimum of thirty (30) feet in width.
2. Corner Lots - Driveways shall be located as follows:

STREET TYPE	DRIVEPAD LOCATION
Local Street	20' from the curb return
Collector Road	40' from the curb return
Minor Arterial	50' from the curb return
Major Arterial	50' from the curb return

3. Width & Section - All driveways will be constructed to the back of sidewalk or to the property line, whichever is less. Driveways shall not be wider than 40' and may not be placed closer than 20' from any curb return. Applicants may submit alternate driveway section for approval by the City Engineer. All driveways shall meet all ADA accessibility requirements. All driveways shall slope 1/4" (1:50 cross slope) for each foot of width across the pedestrian travel path.
4. If drive pads will not be installed because mountable curb is used then the sidewalk thickness shall be increased to six inches (6") thick for the entire length of the sidewalk.

5. Standard Specification for Placement of Concrete Fillets

Fillets shall be a minimum of 6" thick and reinforced & shall meet all ADA specifications. Developments on corner lots shall be required to construct or reconstruct existing fillets and sidewalks to comply with ADA requirements.

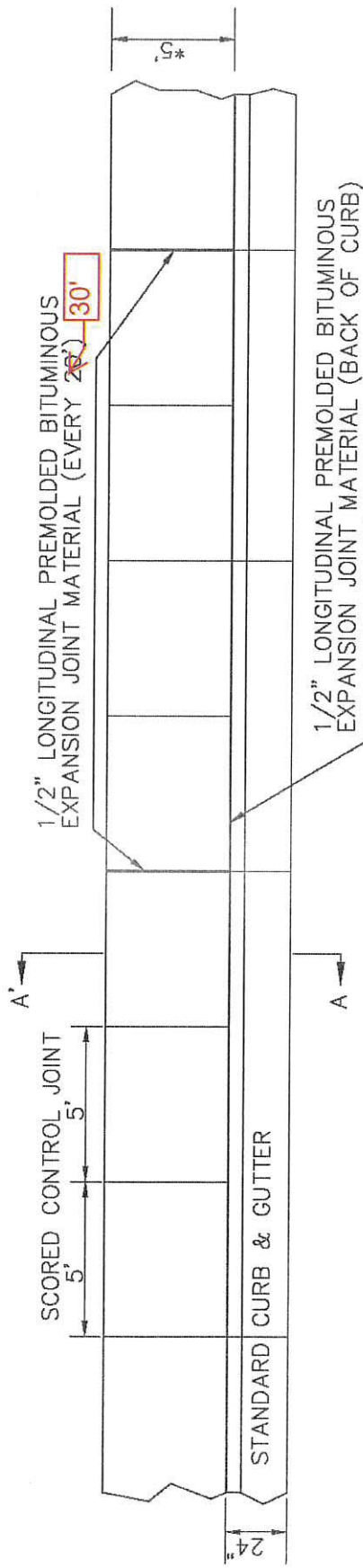

PLAN VIEW

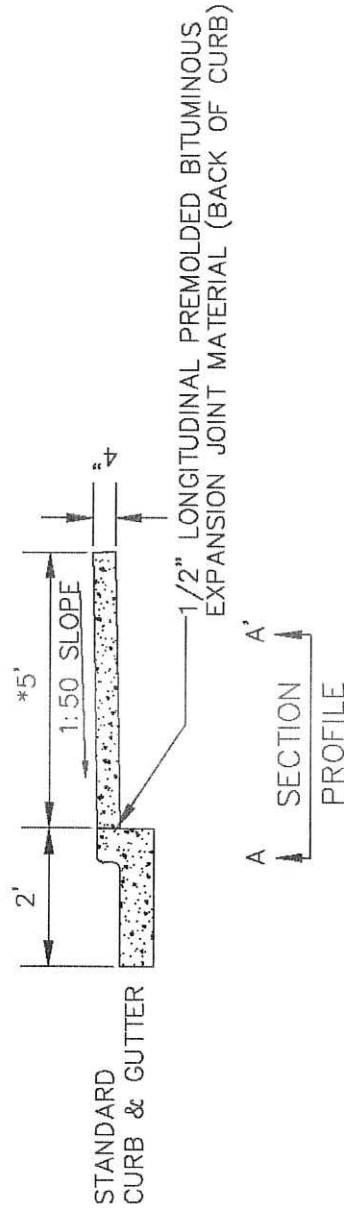

4" - 3000 PSI CONCRETE SIDEWALK

1:50 CROSS SLOPE IS TYPICAL OF SIDEWALK AT ANY LOCATION (MUST MEET ADA PROWAG STANDARDS)
 * SIDEWALK WIDTH FOR LOCAL STREETS IS 5' AND 8' FOR COLLECTOR AND ARTERIAL STREETS
 A 5' SIDEWALK IS PERMITTED FOR COLLECTOR AND ARTERIAL STREETS IF IT IS LOCATED AT THE ROW LINE.

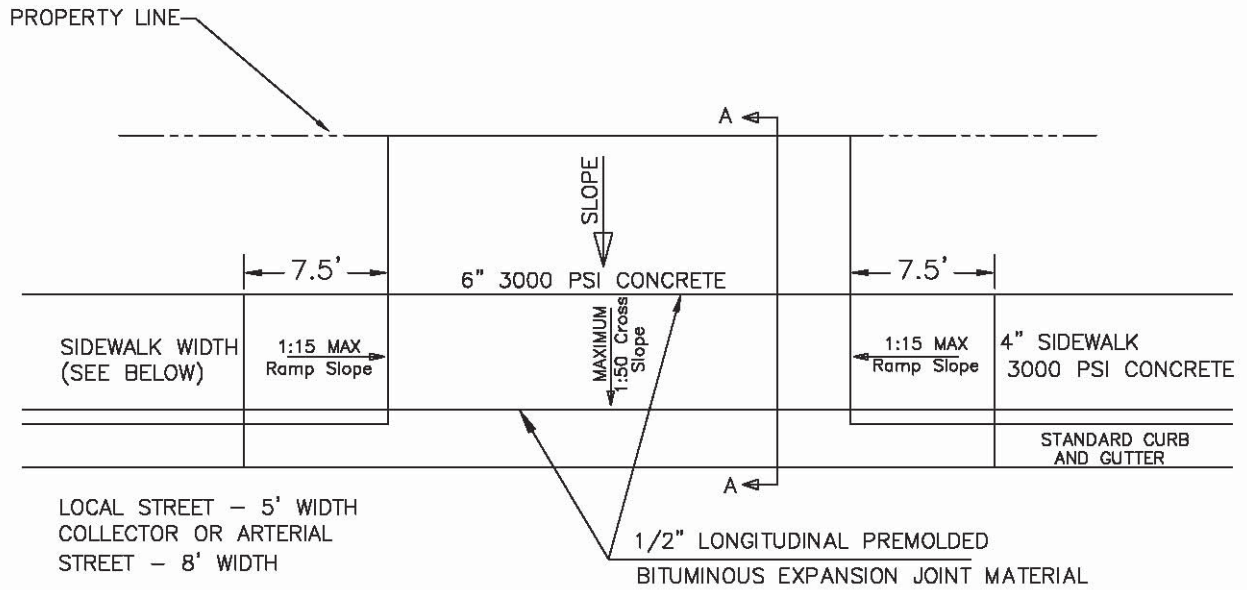

PLAN VIEW

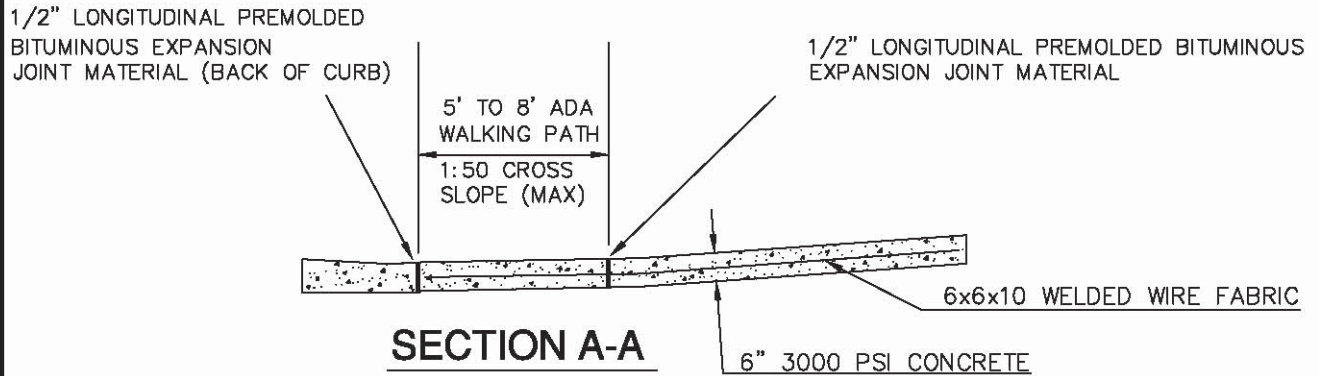

SECTION A-A

**DRIVE PAD DETAIL
SIDEWALK AT THE BACK OF CURB**

6" 3000 PSI CONCRETE

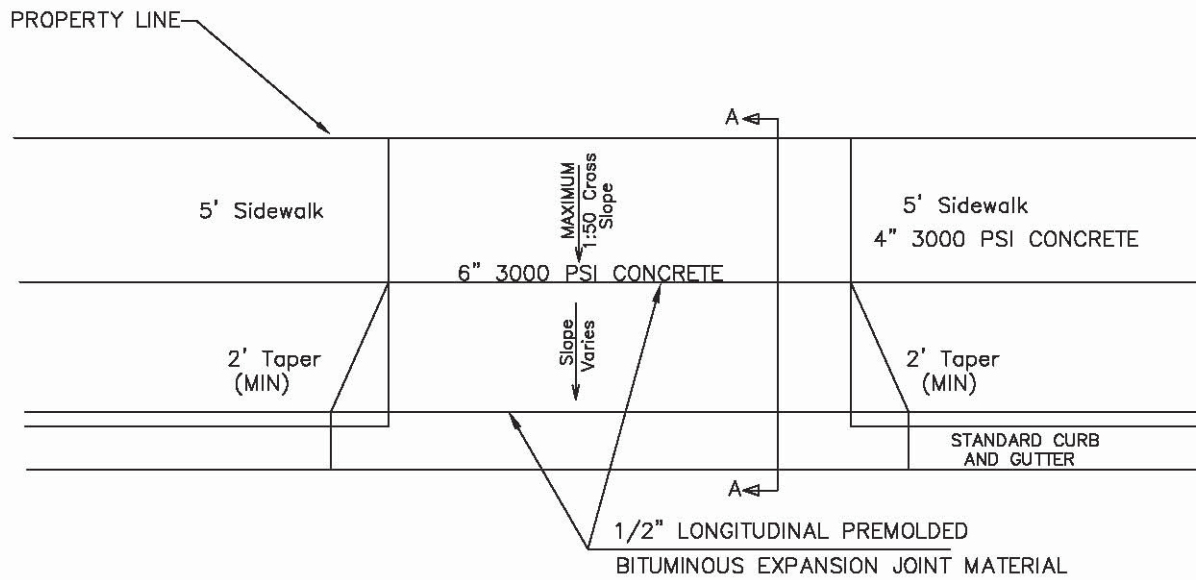

PLAN VIEW

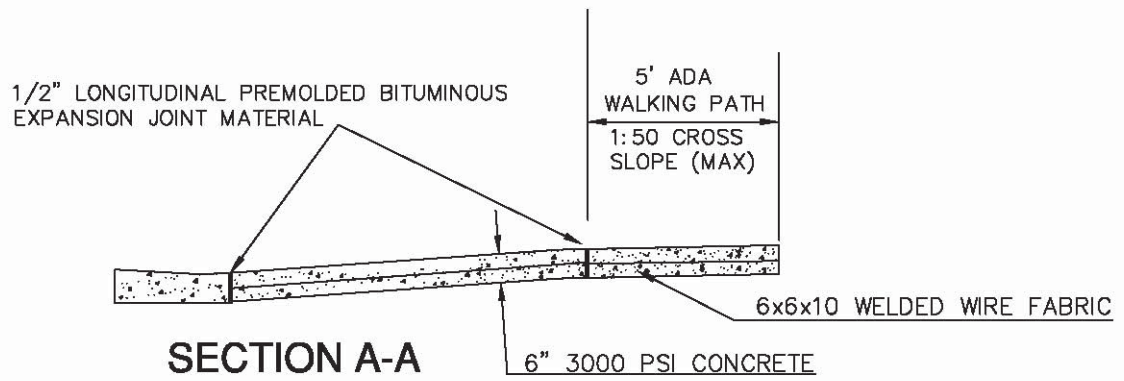

DRIVE PAD DETAIL SIDEWALK AT THE RIGHT-OF-WAY LINE

6" 3000 PSI CONCRETE

ARTICLE 6

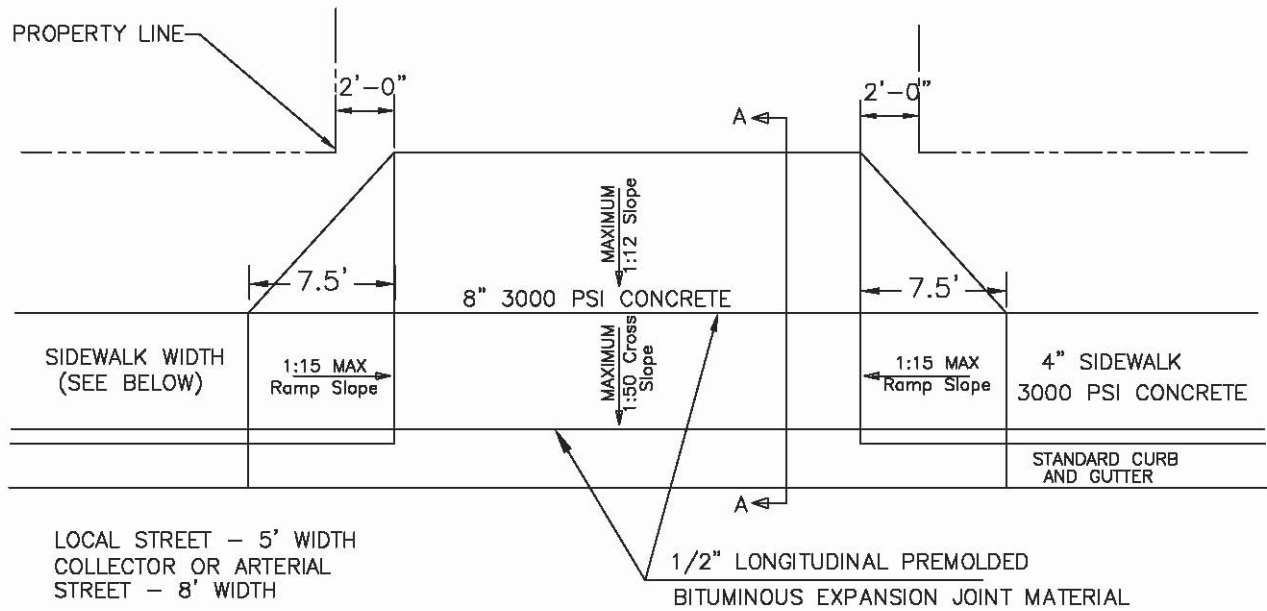

PLAN VIEW

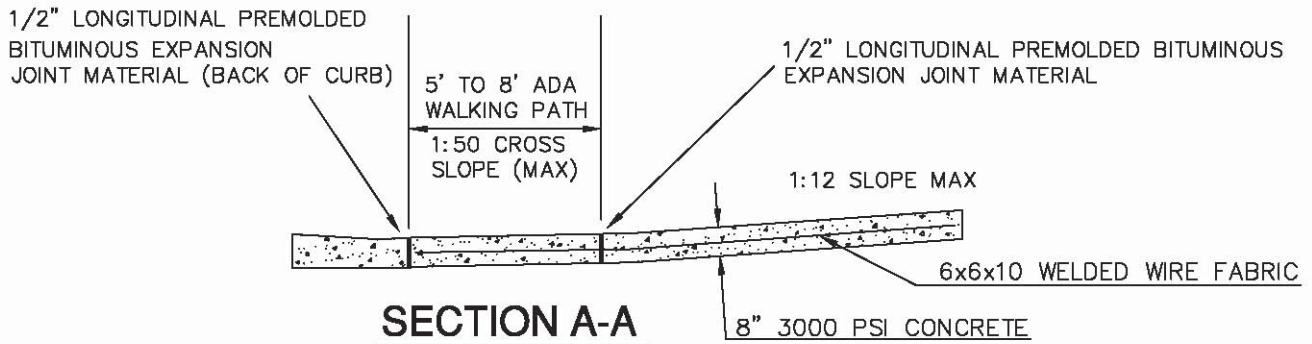

SECTION A-A

**ALLEY PAD DETAIL
SIDEWALK AT THE BACK OF CURB**

8" 3000 PSI CONCRETE

ARTICLE 6

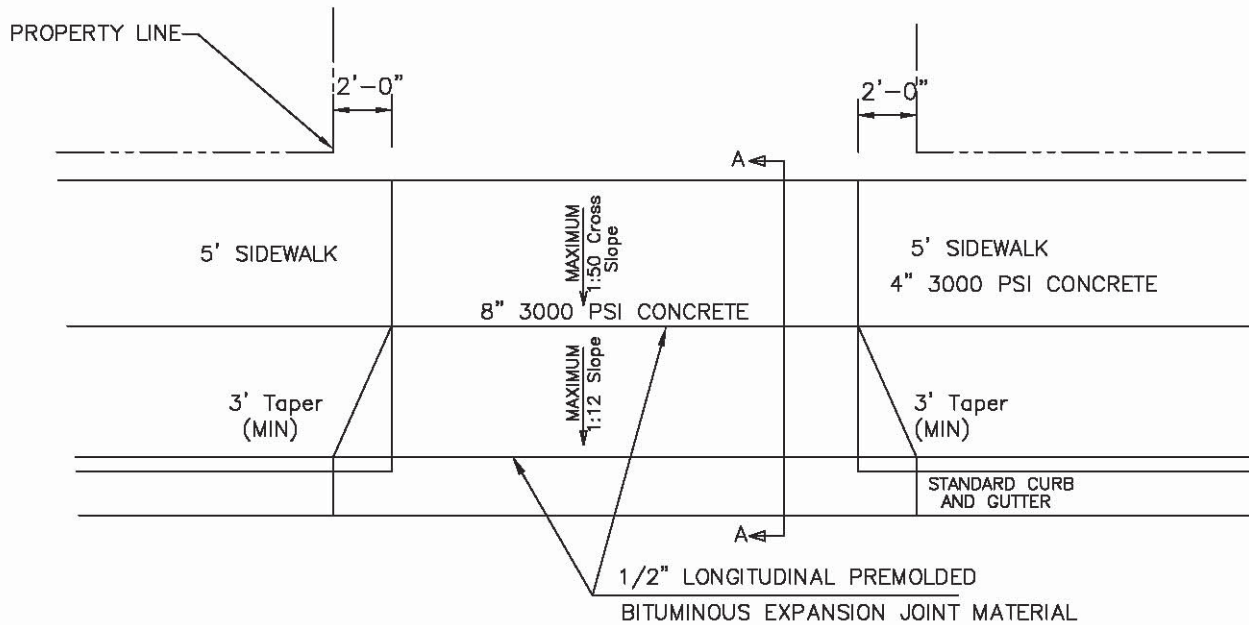

PLAN VIEW

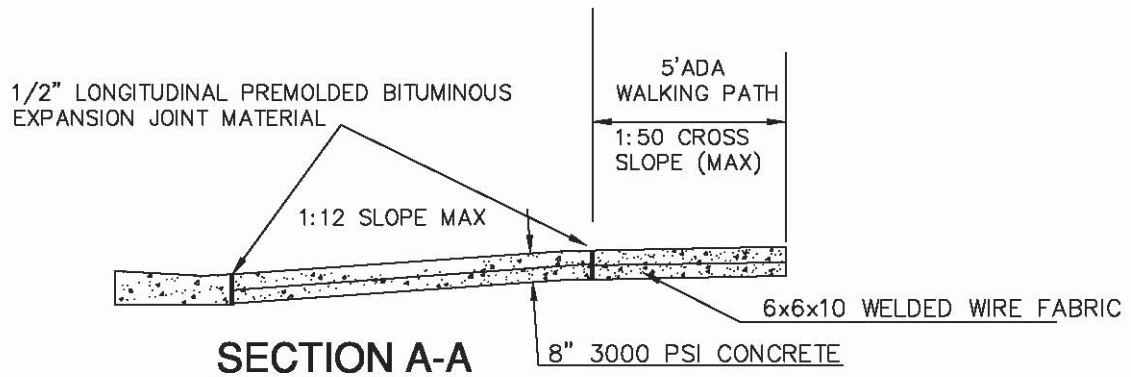

**ALLEY PAD DETAIL
SIDEWALK AT THE RIGHT-OF-WAY LINE**

8" 3000 PSI CONCRETE

ARTICLE 6

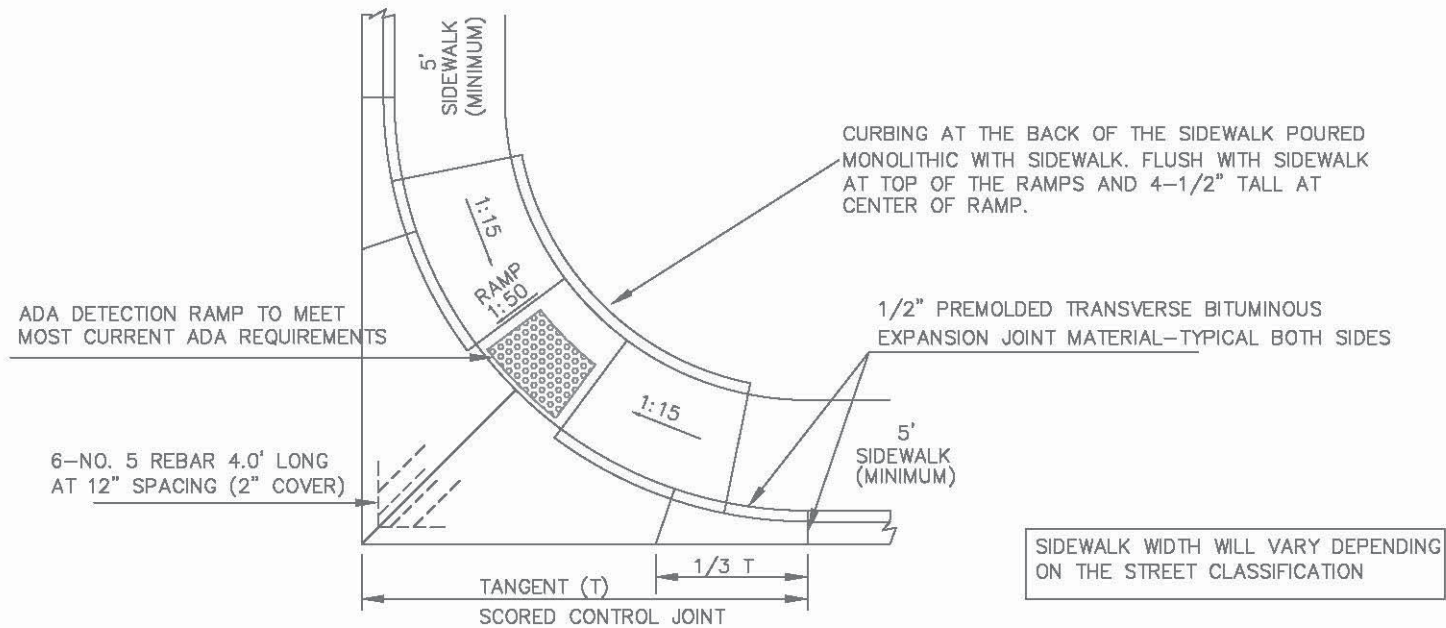

TYPICAL CONCRETE FILLET DETAIL-PLAN
SIDEWALKS AT THE BACK OF CURB

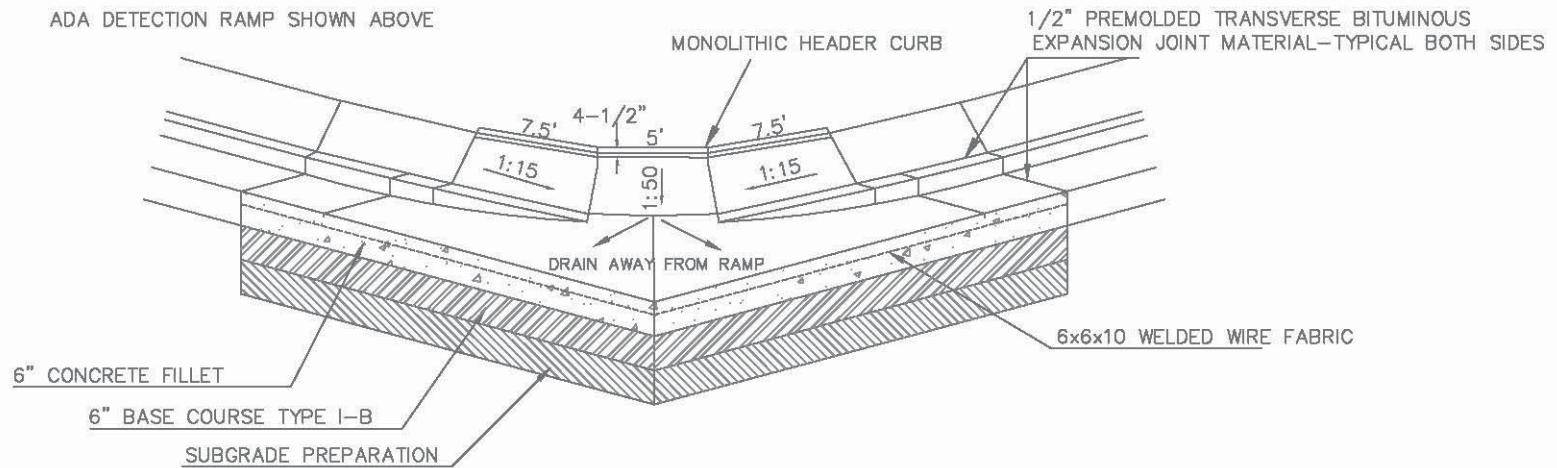

TYPICAL CONCRETE FILLET DETAIL-SECTION
SIDEWALKS AT THE BACK OF CURB

THIS IS A TYPICAL DETAIL. ENGINEER/DEVELOPER MAY SUBMIT A SITE SPECIFIC DETAIL.

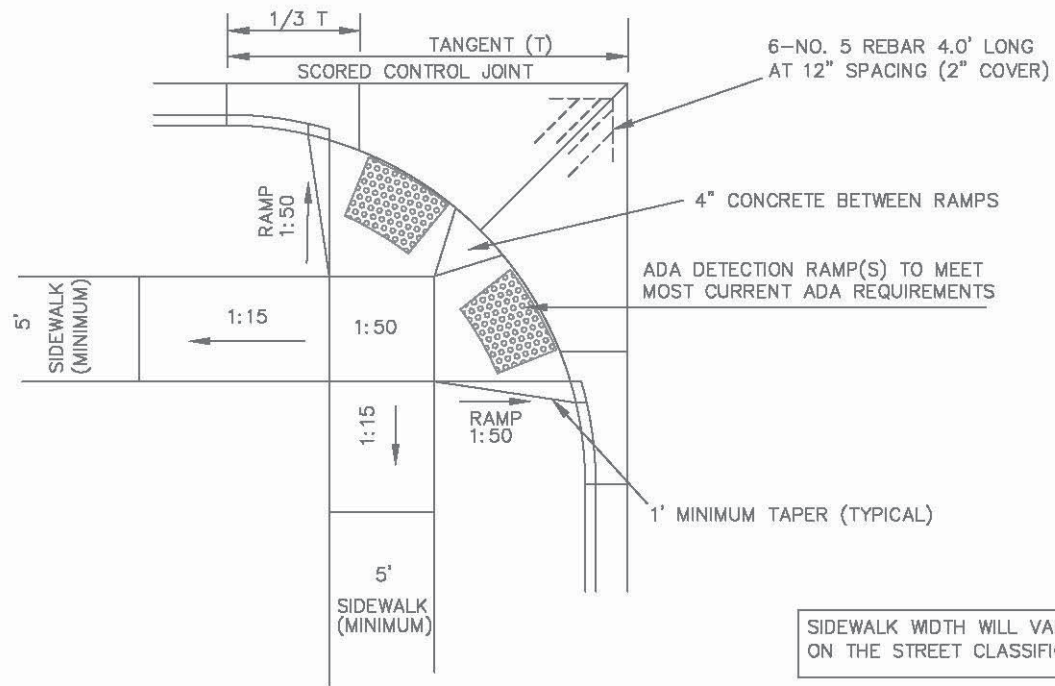

**TYPICAL CONCRETE FILLET DETAIL-PLAN
SIDEWALKS AT THE RIGHT-OF-WAY-LINE**

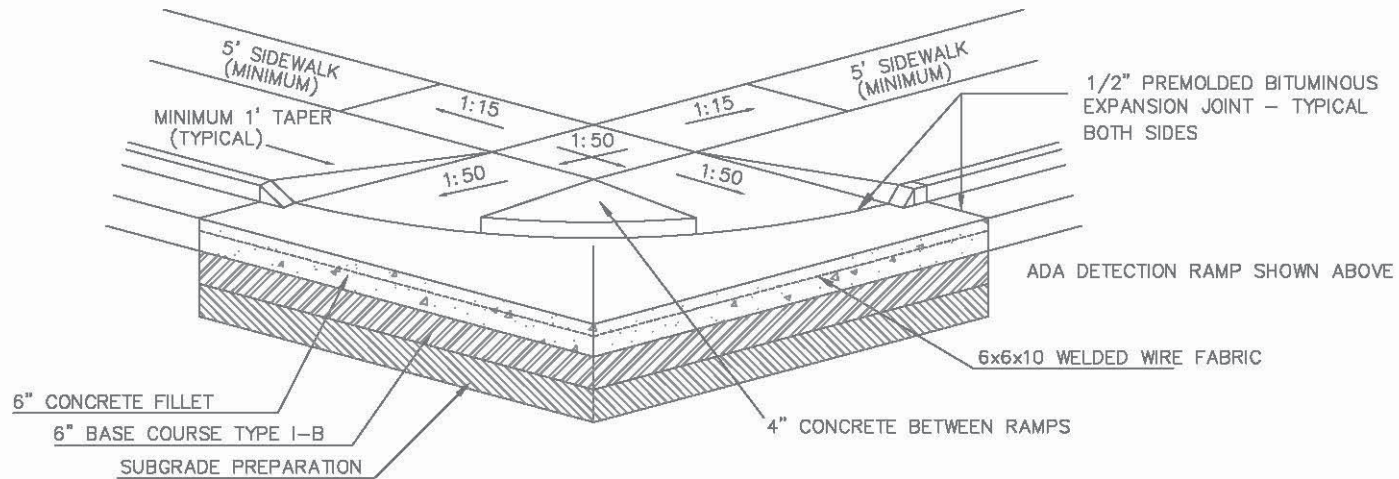

**TYPICAL CONCRETE FILLET DETAIL-SECTION
SIDEWALKS AT THE RIGHT-OF-WAY-LINE**

THIS IS A TYPICAL DETAIL. ENGINEER/DEVELOPER MAY SUBMIT A SITE SPECIFIC DETAIL.

ARTICLE 7
STANDARD SPECIFICATION FOR CURB CONSTRUCTION, CUTS AND
REPLACEMENT

1. General

This section addresses the removal and replacement of curb and gutter sections as defined below. No work or alteration to existing curbs will be allowed without compliance with Article 1 – General Statement of Policies and Specifications.

2. Engineering Data

A. Engineering Plan - The plan for the proposed curb construction, including cuts, shall illustrate all existing and proposed curb section elevations. The grade of the replacement section shall be such that it is continuous with the existing sections to which it is being tied. Any existing utilities in the area shall be noted on the engineering plan.

3. Standard Specifications for Curb Cuts

A. Curb Removal - The procedures for curb removal shall be as follows:

1. Refer to drivepad placement notes in Article 6 for location of drivepads and limits of respective curb removals.
2. The entire section of curb, (i.e. the standup section and gutter section) shall be removed. The breaking off of only the standup section shall not be allowed. The section that is removed shall be properly disposed of by the contractor or owner and shall not be left on the site of the construction or placed in trash bins or receptacles.

B. Replacing Curb and Gutter

1. The section to be replaced shall be in accordance with these Standard Specifications. The replacement section shall conform to the typical sections illustrated in these specifications.
2. All concrete curb and gutter must be protected from freezing for a minimum of four (4) days.
3. Any curbing removed for any reason, shall be replaced within fourteen (14) calendar days, unless otherwise approved by the City of Carlsbad.

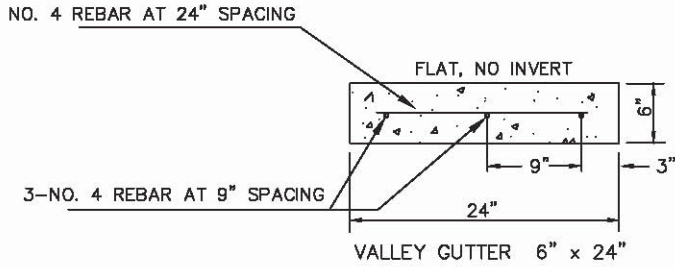

CONCRETE VALLEY GUTTER-24"
 EXPANSION JOINT EVERY 25'
 SCORED CONTROL JOINT EVERY 10'

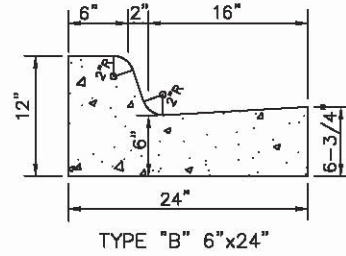

STANDARD CONCRETE CURB & GUTTER-24"

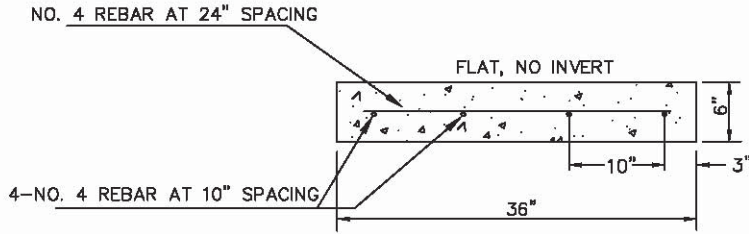

CONCRETE VALLEY GUTTER-36"
 EXPANSION JOINT EVERY 25'
 SCORED CONTROL JOINT EVERY 10'

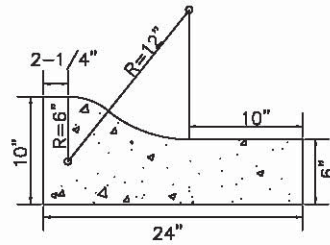

MOUNTABLE CURB AND GUTTER-24"

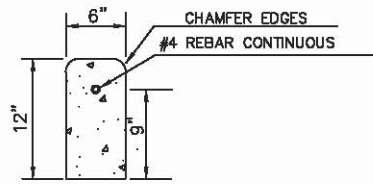

HEADER CURB
 6" x 12"

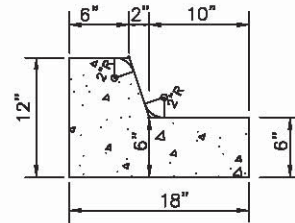

STANDARD CONCRETE CURB & GUTTER-18"

OTHER VARIATIONS FOR CURBING SHALL BE SUBMITTED FOR APPROVAL BY THE CITY.
 STANDARD CURB & GUTTER/VALLEY GUTTER/ HEADER CURB

ARTICLE 8
STANDARD SPECIFICATION FOR UTILITIES

1. *Interruption of Service and Notice*

- A. Prior to beginning any utility work, except for emergency repairs, the Contractor shall be required to obtain the appropriate permit(s) at the Planning, Engineering & Regulation Department. All work performed within the Public Right-Of-Way requires that all permits, fees and approvals be obtained prior to construction.
- B. The Utility Contractor shall be responsible for all construction permits for the work site.
- C. The Utility Contractor shall notify the City of Carlsbad and adjacent property owners at least forty-eight (48) hours in advance of the start of construction.
- D. All utility extensions to be dedicated to the City shall be designed by a Licensed Professional Engineer registered in the State of New Mexico.
- E. The City of Carlsbad may require confirmation testing at any time during the construction. This cost will be the responsibility of the Contractor.
- F. Prior to acceptance of the utility by the City, a letter of completion, signed by a Licensed Professional Engineer registered in the State of New Mexico, indicating that the Utility Contractor has met his or her obligations shall be submitted to the City.
- G. The Utility Contractor shall make himself or herself aware of current OSHA requirements concerning trench widths and depths. If the trench width requires special bedding or higher strength pipe, the Contractor shall provide these at his or her own expense.

2. *Connection to Existing Infrastructure System(s)*

- A. Prior to starting any work involving connections to the existing infrastructure system, the Contractor shall notify the City of Carlsbad Utilities Department.
- B. Replacement of paving following backfill shall take place within three (3) days and consist of materials equal to or better than the original paving.
- C. Sewer service is considered private from the sewer main tap or stubout to the house or structure. Water service is considered private from the water meter to the house.

- D. Service lines - Upon payment to the City for the requested water service and meter, the City will tap the water main, install the service line and the water meter. The City will then charge the contractor/developer for time and materials.

3. Public Convenience and Access

- A. The Contractor shall conduct and schedule work in order to minimize traffic obstructions and other inconveniences to the public. Testing, purging, transfer of service and backfill of each section of line shall immediately follow the installation.
- B. The Contractor shall provide traffic control for the duration of the project in accordance with the Manual on Uniform Traffic Control Devices (MUTCD), latest edition. The Contractor shall submit a Traffic Control Plan to the City of Carlsbad a minimum of fourteen (14) calendar days prior to beginning the project.

4. Source of Supply and Quality of Materials

All materials used in the construction of the work are to be furnished by the Contractor at his own expense. These Specifications require all materials to be new and unused and utilized in such a manner as to produce completed construction that is authorized and acceptable in every detail. Only materials conforming to the requirements of these Specifications will be accepted and used in the work. Materials shall be stored to insure the preservation of their quality and fitness for the work.

5. Railroad and State Highway Crossings

Railroad, NMDOT, and County (if applicable) Highway crossings or parallel installments, shall be in conformance with Railroad, Highway and County specifications. Contractors shall furnish the City of Carlsbad an approved permit application for the crossings.

6. Utility Stubouts

If the utility is located under a paved surface, the utility shall be stubbed out to the property line and marked electronically for future location, at the Contractor's expense. If possible during the construction sequence, the contractor shall "stamp" the new curb & gutter at the crossing location with the appropriate symbol for the utility.

7. Construction Notes

- A. Layout of Work: The Utility Contractor shall be responsible for adherence to the lines and grades of the plans and profiles as designed by the Engineer.
- B. Cleanup: The Contractor shall maintain and leave the project in a clean and neat condition.

- C. Density Failures: The cost of all density failures and retests shall be borne by the Contractor. All density failures shall be retested and the accompanying passing density test shall be submitted to the City.
- D. "As Built/Record" Drawings: The Contractor shall prepare an accurate set of "As Built/Record" drawings and include all testing results and reports for all work performed in public rights-of-way and for all work to be dedicated to the City. The Contractor shall record thereon the locations, depth, size, type of material, any other pertinent data, and all changes made in the work that differ from the approved construction drawings. Prior to acceptance of the project by the City, the Contractor shall provide: two (2) hard copies, one (1) PDF file, and one (CAD) file.

8. Utility Service Line on Replats

- A. When a replat of property necessitates additional utility locations, relocations or new stubouts, the City's policy is:
 - 1. The developer shall submit to the City a plan, prepared by a Licensed Professional Engineer registered in the State of New Mexico, which details the changes. The plan shall be reviewed and approved by the City prior to the changes being made.
 - 2. Fire hydrants shall be located within the public right-of-way and adjacent to new lot lines.
 - 3. The above shall be accomplished at the developer's expense.
 - 4. These provisions apply to all utilities regardless of the owner.

9. Tracer Wire Specifications

- 1. All Trace wire and Trace wire products shall be domestically manufactured in the USA.
- 2. All Trace wire shall have an HDPE insulation intended for direct bury, color coated per APWA standard for specific utility being marked.
- 3. Open Trench-Trace wire shall be #12 AWG Copper Clad Steel, High Strength with minimum 450 lb. break load, minimum 30 mil HDPE insulation thickness.
- 4. Direct bury connections- shall include 3-way lockable connectors and a mainline to lateral lug shall be dielectric silicon filled to seal out moisture and corrosion, and shall be installed in a manner so as to prevent any uninsulated wire exposure.
- 5. Tracer wire shall be installed on all new sewer service and main lines, regardless of size. Tracer Boxes shall be a Snake Pit Magnetized Tracer

Box, Roadway Box or approved equal and shall be installed outside the street pavement but within the road right-of-way as near as possible to the manhole or as directed by the City of Carlsbad. A 6" concrete collar (same as water valve box) shall be installed at the tracer box.

6. Grounding of trace wire shall be achieved by use of drive magnesium grounding anode with a minimum of 20 ft of #12 Red HDPE insulated copper clad steel wire connected to anode (minimum 1.5lb) specifically for manufactured for this purpose and buried at the same elevation as the utility.
7. Grounding anode wire shall be connected to the identified terminal on all access boxes.
8. Testing of all new trace wire installations shall be located using typical low frequency (512Hz) line tracing equipment, witnessed by the contractor, engineer and facility owner prior to acceptance of ownership.

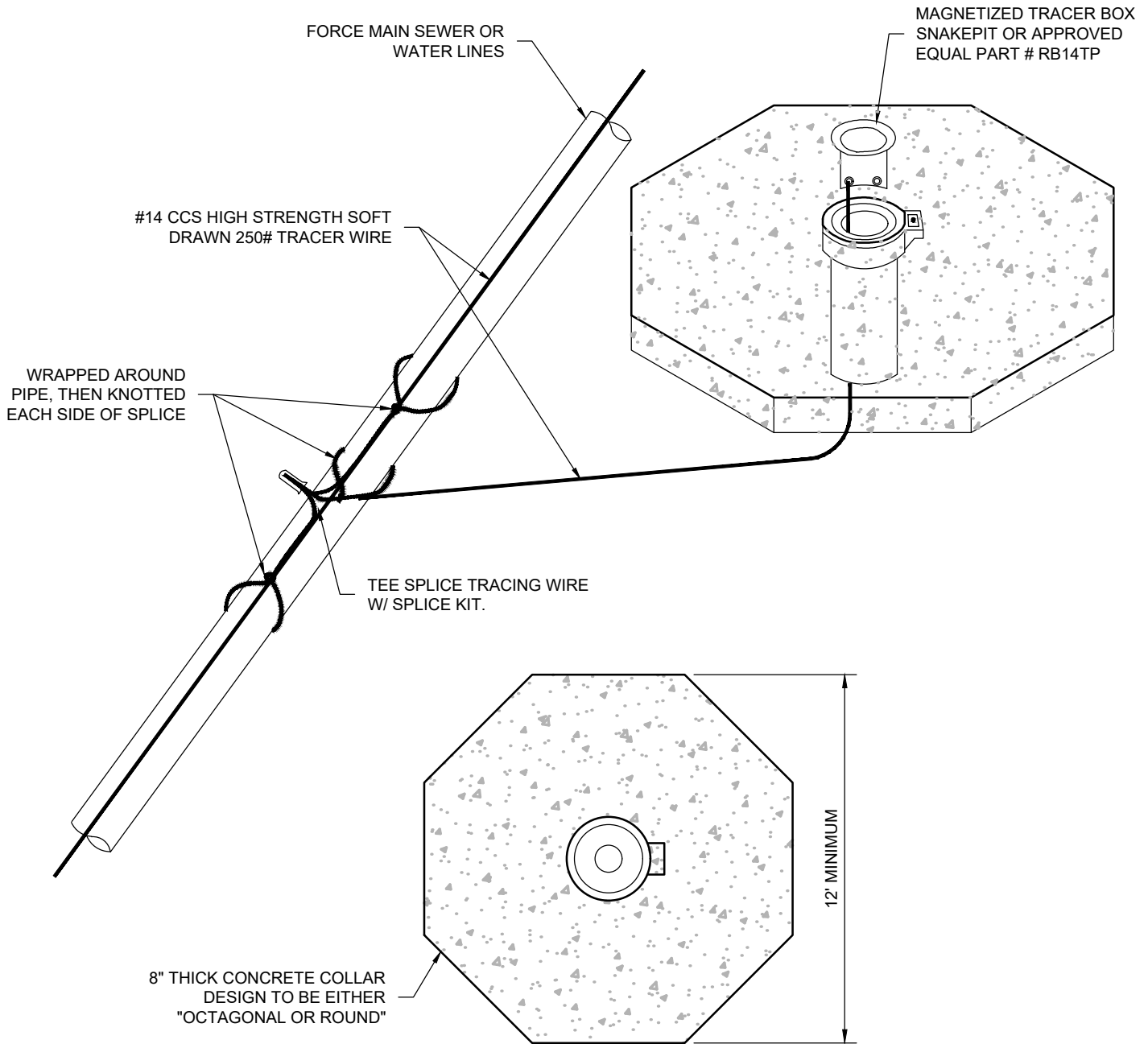

CONCRETE COLLAR

NOTES:

1. A 8" THICK CONCRETE COLLAR (SAME AS WATER VALVE BOX) SHALL BE INSTALLED WITH THE TRACER BOX. SEE ARTICLE 10 AND ARTICLE 11 FOR TRACER BOX SPACING AND MATERIALS.
2. TEST BOX LOCATION MAY VARY, UP TO 50 FT. FROM FORCED MAIN LINE.
3. REFER TO STANDARDS AND MATERIALS LISTS FOR MATERIALS MATERIALS AND MANUFACTURE'S INSTALLATION INSTRUCTIONS.

TRACER BOX DETAIL

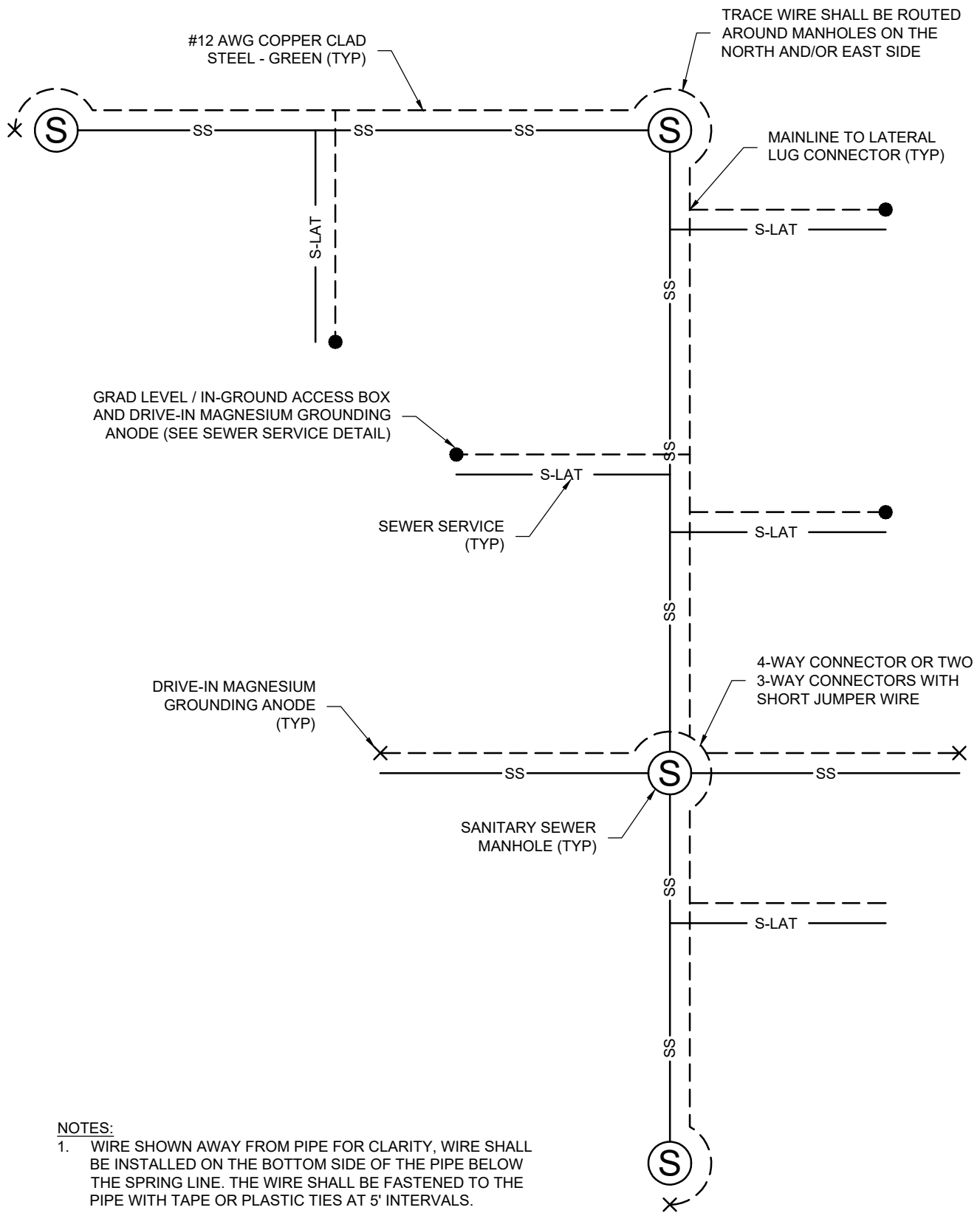

NOTES:

1. WIRE SHOWN AWAY FROM PIPE FOR CLARITY, WIRE SHALL BE INSTALLED ON THE BOTTOM SIDE OF THE PIPE BELOW THE SPRING LINE. THE WIRE SHALL BE FASTENED TO THE PIPE WITH TAPE OR PLASTIC TIES AT 5' INTERVALS.

TRACE WIRE PLAN (SEWER)

NOT-TO-SCALE



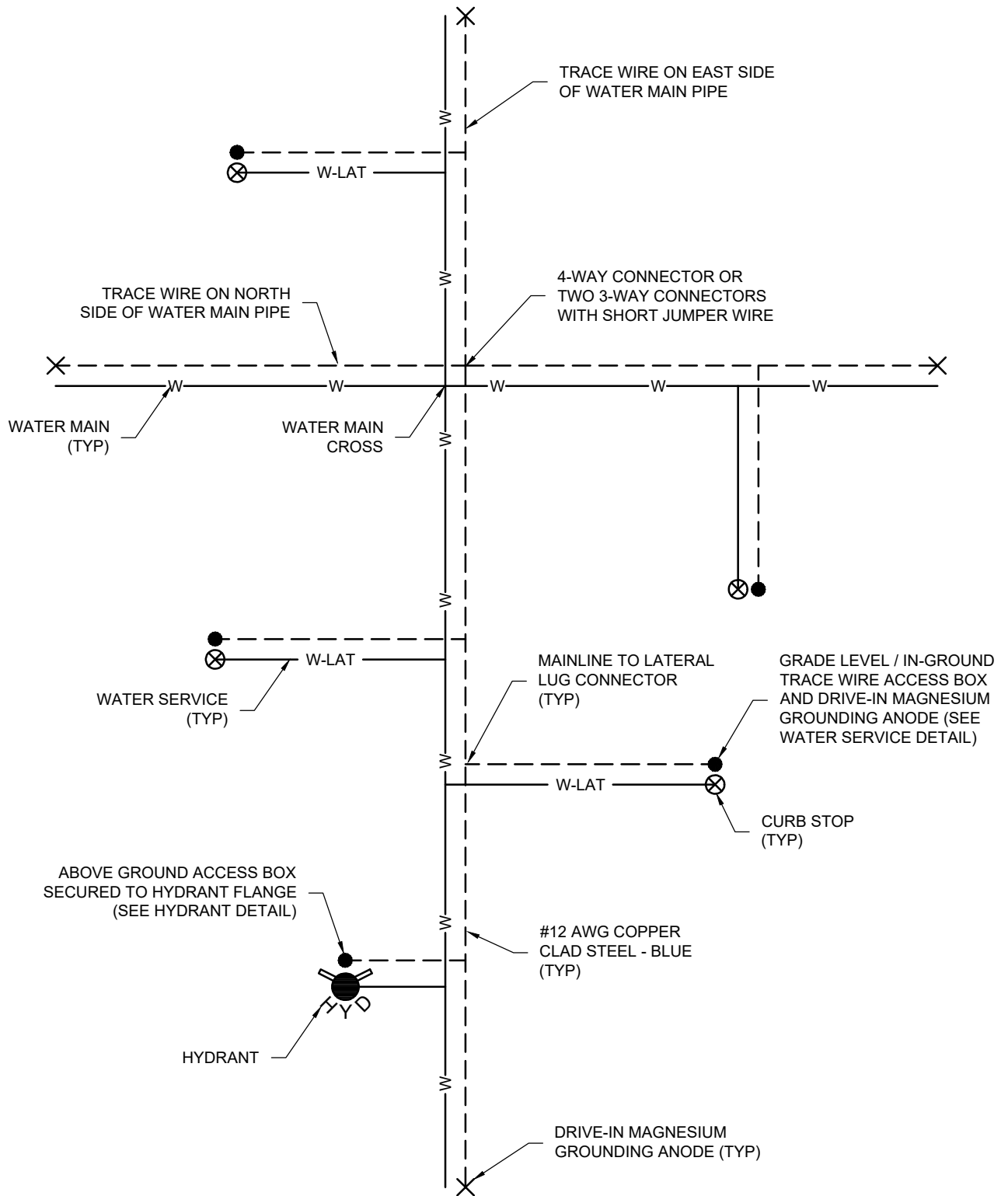

NOTES:

1. WIRE SHOWN AWAY FROM PIPE FOR CLARITY, WIRE SHALL BE INSTALLED ON THE BOTTOM SIDE OF THE PIPE BELOW THE SPRING LINE. THE WIRE SHALL BE FASTENED TO THE PIPE WITH TAPE OR PLASTIC TIES AT 5' INTERVALS.

TRACE WIRE PLAN (WATER)

NOT-TO-SCALE



ARTICLE 9
STANDARD SPECIFICATION FOR BORING, DRILLING AND JACKING

1. *General*

Construction and materials related to the installation of casing, culverts, or conduits, (of the type and size called for in the contract) by boring, drilling or jacking through embankment, under roadways or railways, and at other locations, in conformance with the lines, grades, and dimensions shown on the plans, shall conform to the NMSSPWC Standard Specifications, Section 710 – Boring, Drilling and Jacking.

ARTICLE 10
STANDARD SPECIFICATION FOR WATER LINES

1. Description

This section addresses the furnishing and construction of water lines complete with all appurtenances and accessories. The construction and materials shall conform to the NMSSPWC Standard Specifications, Sections 121 thru 130, and Section 800 Water Transmission, Collector, Distribution and Service Lines, except as modified herein.

2. Materials

- A. All materials shall be new and unused and be utilized in such a manner so as to produce completed construction that is authorized and acceptable in every detail. Only materials conforming to the requirements of these Specifications will be accepted. Materials shall be stored so as to insure the preservation of their quality and fitness for the work. The Contractor shall include shop drawings with all pertinent technical information and specifications for all items to be furnished. The Contractor shall provide the City with certification from the manufacturers for all materials, which attest compliance to appropriate specifications.
- B. Water distribution lines shall be a minimum of 6", PVC DR 18 pipe and shall conform with requirements of AWWA C-900 - Class 150 or as required by the City of Carlsbad Utilities Director. All service mains and Transmission lines shall be buried to a minimum of 48" to top of pipe.
- C. Gate valves shall be a bonded resilient seat, non-rising stem type, mechanical joint, fuse bonded epoxy coated inside and out, with a 2" (inch) operating nut, opens counter-clockwise. Valves used for isolation of the main lines shall be a MJ x MJ type. Valves used for fire hydrants shall be a MJ x Flange type. All brass or bronze parts shall comply with AWWA C509.
- D. Fire hydrants shall be a four and half foot (4.5') bury, traffic type, Mueller Super Centurion 250 or Clow Medallion Model Number 2545. A Flange x MJ gate valve shall be provided with the hydrant. Fire Hydrants shall be colored "Chrome Yellow" and be epoxy coated or have a baked on finish. Extensions will be required to maintain four (4.5') depth.
- E. Valve boxes shall be "Shorty valve boxes No. 70, as manufactured by Western Iron Works, with "Water" cast in the lid and must be approved by the City of Carlsbad. If Valve box is located within Roadway the tracer box is not required. If outside of roadway tracer box to be located in valve collar.
- F. Service saddle: See Water Service Lateral Detail.
- G. Corporation stops: See Water Service Lateral Detail.
- H. Curb stops: See Water Service Lateral Detail.
- I. Meter couplings: See Water Service Lateral Detail.

- J. Service lines installed crossing the street, shall be placed inside of 4" schedule 40, PVC conduit. The conduit shall extend a minimum of one-foot (1') beyond the curb lines. Service lines 1" or 2" shall be blue Rehau municipex pipe for C.T.S. pipe (100' role) (See Water Service Lateral Detail).
- K. Mechanical joint restraining accessories shall be a Mechanical Joint Restraining Gland Kits as manufactured by EBAA Iron Co. and shall be used at every mechanical joint, tee, valve, fire hydrant, etc.
- L. 6" wide metallic warning tape shall be placed twenty four inches (24") above all water lines. A metallic tape or approved locator product will be used by the Contractor. Contractor will submit proposed material data to City of Carlsbad Utilities Director for approval prior to commencement of operations. The City of Carlsbad reserves the right to require a sample of product. The line locator wire shall be secured/taped to the top of all mains and service lines and not be wrapped around the pipe.
- M. Meter boxes shall be an East Jordan Iron Works 1527 C-14, product #380001527. Meter cover assembly shall be product #32131547A02 with 2" sensor hole.
- N. Fittings shall be a mechanical joint (MJ), class C-153 S.S.B. type, ductile iron pipe fittings. All Fittings shall be fusion bonded epoxy coated or wrapped in 8 mill LLDPE pipe wrap.

3. Construction Requirements

A. Flushing and Disinfecting Water Lines.

All water lines shall be flushed and chlorinated in conformance with the following requirements:

1. Keep ends covered while lines are being laid.
2. Flush line at a rate of at least 3-5 fps until all loose foreign material is removed.
3. Fill line with chlorine solution (NSF/ANSI 60&61 Approved & AWWA C-651) having enough chlorine for a dosage of 250 ppm for all of the water in the line.
4. Bleed the point most remote from the point of filling as long as the chlorine residual continues to rise. In any case, the chlorine residual must rise above 100 ppm.
5. Leave the chlorine solution in the line at least 24 hours after closing bleed valve.
6. After the line has set for 24 hours, flush the line till a 0.2 mg/L minimum chlorine residual remains in the line. Maintain this residual in the line until bacteriological samples prove the line to be satisfactory.
7. Call the Water Department to collect one sample for bacteriological analysis

for every 1200 feet of new main installed (per NMED/AWWA).

8. Should the results of the analysis be unsatisfactory, disinfection will be repeated, and two additional samples will be collected and analyzed before placing the line in service again.
9. Water line may be placed in service only after successful disinfection has been completed.

B. Hydrostatic Tests

All waterlines and appurtenances shall be tested by the Contractor after completion. A hydrostatic test pressure of one hundred fifty (150) pounds per square inch shall be applied to all lines. The test pressure shall be maintained for a period of two hours. If the line fails to hold pressure, a leakage test pressure of one hundred (100) pounds per square inch shall be applied to all lines and accurate measurement made of the volume of water required to maintain the test pressure for a period of one hour. No section of pipe line which shows a leakage in excess of 10 gallons per day per mile of pipe per inch of diameter will be accepted. Any pipe failing under hydrostatic test or exceeding the allowable leakage, shall be repaired by the Contractor and retested. Allowable leakage for the one hour period @ 100 psi can be calculated as follows:

Allowable Leakage (Gallons) =

$$\frac{(\text{Pipe Length in Feet}) \times (\text{Pipe Diameter in Inches})}{13,320}$$

C. Backfill requirements

1. Water lines installed inside of the roadway prism shall meet the specifications In Article 3.
2. When flow fill backfill is used, all mechanical joints, valves, fire hydrants, restraining devices, corporation stops, etc. shall be completely wrapped in plastic prior to back filling. The plastic shall have a minimum mil thickness of 8mil.
3. Water lines installed outside of the roadway prism shall meet the specifications of Article 4.
4. If the Soil Type is unknown please use soil type "ML Soil Conditions" for restraint calculations.

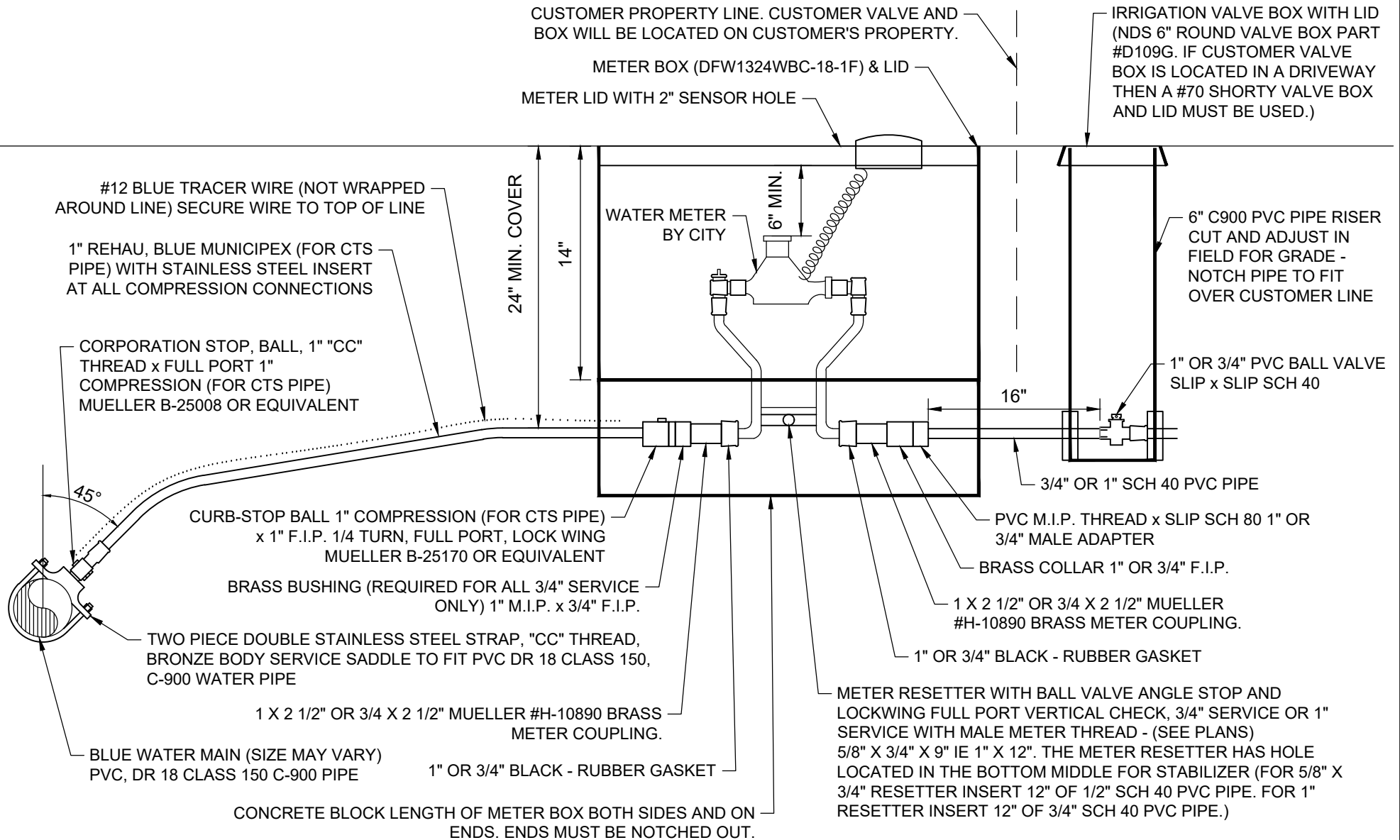

NOTES:

1. ANY DEVIATION OF COMPONENT MODELS SHOWN SHALL BE APPROVED BY THE ENGINEER AND THE CITY OF CARLSBAD.
2. NEW WATER SERVICES TO BE INSTALLED 5'-0" FROM SIDE LOT LINE UNLESS OTHERWISE SHOWN IN THESE PLANS.
3. SERVICE LINE SHALL BE ONE CONTINUOUS PIPE. NO SPLICES WILL BE ACCEPTED. LINE SHALL BE 24" MINIMUM BURIAL.
4. ALL BRASS FITTINGS MUST BE NO LEAD/LOW LEAD.
5. ALL COMPRESSION CONNECTIONS SHALL BE MUELLER 110 CONDUCTIVE COMPRESSION CONNECTION TYPE.
6. EQUIVALENT PARTS AND MATERIALS MAY BE USED OF APPROVED BY THE CITY OF CARLSBAD.

3/4" - 1" WATER SERVICE LATERAL

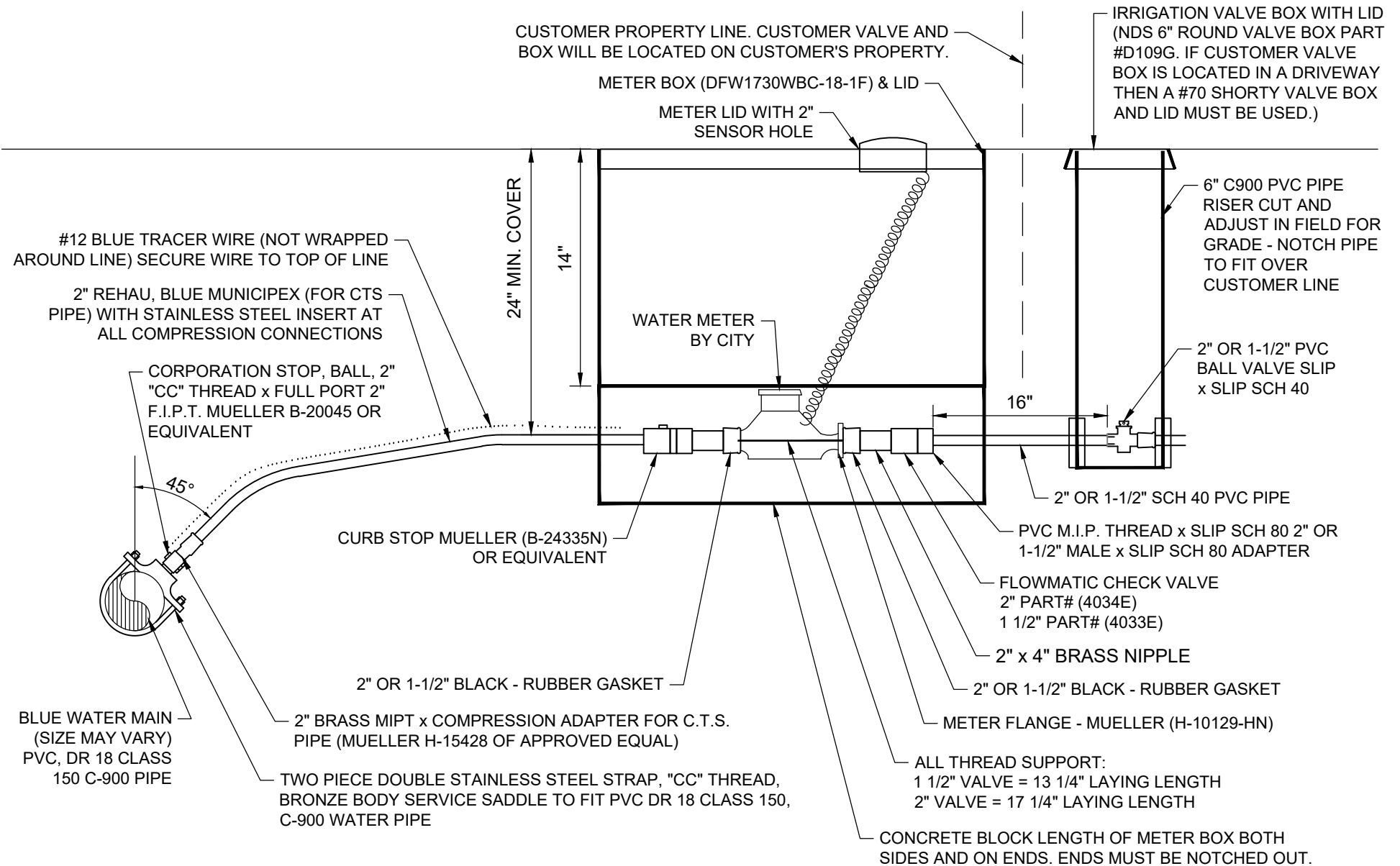

NOTES:

1. ANY DEVIATION OF COMPONENT MODELS SHOWN SHALL BE APPROVED BY THE ENGINEER AND THE CITY OF CARLSBAD.
2. NEW WATER SERVICES TO BE INSTALLED 5'-0" FROM SIDE LOT LINE UNLESS OTHERWISE SHOWN IN THESE PLANS.
3. SERVICE LINE SHALL BE ONE CONTINUOUS PIPE. NO SPLICES WILL BE ACCEPTED. LINE SHALL BE 24" MINIMUM BURIAL.
4. ALL BRASS FITTINGS MUST BE NO LEAD/LOW LEAD.
5. ALL COMPRESSION CONNECTIONS SHALL BE MUELLER 110 CONDUCTIVE COMPRESSION CONNECTION TYPE OR APPROVED EQUAL.
6. EQUIVALENT PARTS AND MATERIALS MAY BE USED IF APPROVED BY THE CITY OF CARLSBAD.

TYPICAL 1 1/2" - 2" WATER SERVICE LATERAL

CITY OF CARLSBAD MEGALUG RESTRAINT CHART

LENGTH OF RESTRAINT (LR) FOR C-900 PVC PIPE

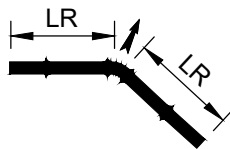
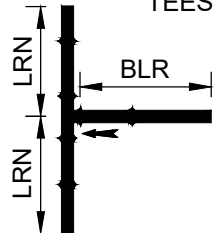
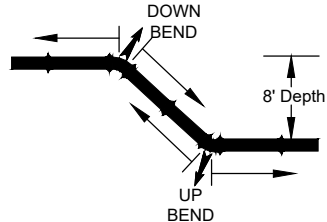
<p>NOMINAL PIPE SIZE</p>  <p>If Soil Type unknown, use Type ML Soil Condition</p>	<p>HORIZONTAL BENDS</p> 			<p>TEES</p> 		<p>VERTICAL OFFSETS</p> 			
					45° BEND FITTING		22.5° BEND FITTING		
	90° LR =	45° LR =	22.5° LR =	LRN = 5'	LRN = 10'	DOWN BEND	UP BEND	DOWN BEND	UP BEND
Soil Type: CL									
3"	11'	5'	2'	4'	1'	13'	4'	6'	2'
4"	14'	6'	3'	8'	1'	16'	5'	8'	2'
6"	20'	8'	4'	19'	1'	23'	7'	11'	3'
8"	26'	11'	5'	32'	13'	30'	9'	14'	4'
10"	31'	13'	6'	41'	23'	36'	10'	17'	5'
12"	37'	15'	7'	53'	34'	43'	12'	21'	6'
Soil Type: ML									
3"	14'	6'	3'	11'	1'	14'	3'	7'	1'
4"	16'	7'	3'	18'	1'	16'	3'	8'	2'
6"	23'	10'	5'	33'	13'	23'	5'	11'	2'
8"	30'	12'	6'	51'	30'	30'	6'	15'	3'
10"	36'	15'	7'	64'	43'	37'	8'	18'	4'
12"	42'	18'	8'	79'	58'	43'	9'	21'	4'

DESIGN PARAMETERS:

SOIL TYPE= CL, CLAY W/ LOW LIQUID LIMIT
 SOIL TYPE= ML, SILT LOW W/ LOW LIQUID LIMIT
 TRENCH TYPE= 3
 TEST PRESSURE= 150 PSI
 SAFETY FACTOR= 1.5
 MINIMUM BURY DEPTH= 4'
 VERTICAL CALCULATIONS BASED ON 8' LOW SIDE DEPTH.

LRN= SHORTEST LENGTH OF PIPE RESTRAINED TO THE RUN OF THE TEE FITTING(BOTH SIDES OF TEE).

➔ = DIRECTION OF THRUST

CITY OF CARLSBAD
MEGALUG RESTRAINT CHART
 LENGTH OF RESTRAINT (LR) FOR C-900 PVC PIPE

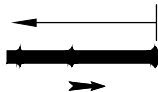
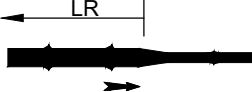
NOMINAL PIPE SIZE 	DEAD ENDS  (and valves each side.)	REDUCERS 			
		PIPE SIZE	TO	PIPE SIZE	LR=
Soil Type: CL					
3"	22'				
4"	27'	4"	→	3"	9'
6"	38'	6"	→	4"	20'
8"	50'	8"	→	6"	21'
10"	61'	10"	→	8"	20'
12"	72'	12"	→	10"	35'
Soil Type: ML					
3"	33'				
4"	40'	4"	→	3"	13'
6"	56'	6"	→	4"	29'
8"	73'	8"	→	6"	31'
10"	88'	10"	→	8"	30'
12"	104'	12"	→	10"	51'

DESIGN PARAMETERS:

SOIL TYPE= CL, CLAY W/ LOW LIQUID LIMIT
 SOIL TYPE= ML, SILT LOW W/ LOW LIQUID LIMIT
 TRENCH TYPE= 3
 TEST PRESSURE= 150 PSI
 SAFETY FACTOR= 1.5
 MINIMUM BURY DEPTH= 4'
 VERTICAL CALCULATIONS BASED ON 8' LOW SIDE DEPTH.

LRN= SHORTEST LENGTH OF PIPE RESTRAINED TO THE RUN OF THE TEE FITTING(BOTH SIDES OF TEE).

➔ = DIRECTION OF THRUST

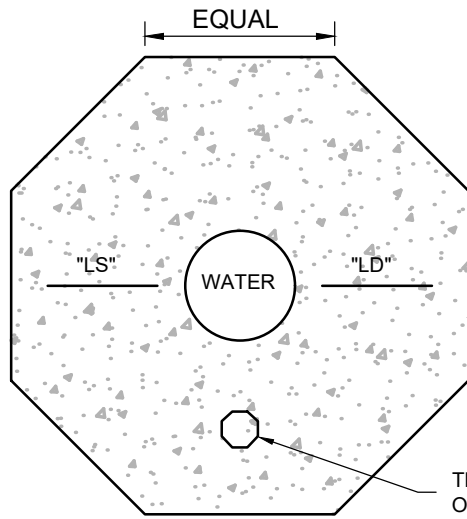

"LS" = LINE SIZE
 "LD" = LINE DIRECTION - 6" LONG 1/2" WIDTH

TOP OF CONCRETE COLLAR SHALL BE STAMPED WITH THE LINE SIZE AND LINE DIRECTION.
 MINIMUM LETTER SIZE SHALL BE 3" IN HEIGHT.

COLLAR DESIGN TO BE EITHER "OCTAGONAL OR ROUND" FOR VALVE BOXES & TRACER WIRE BOXES.

TRACER BOX LOCATION
 OUTSIDE OF ROADWAY

CONCRETE COLLAR DETAIL

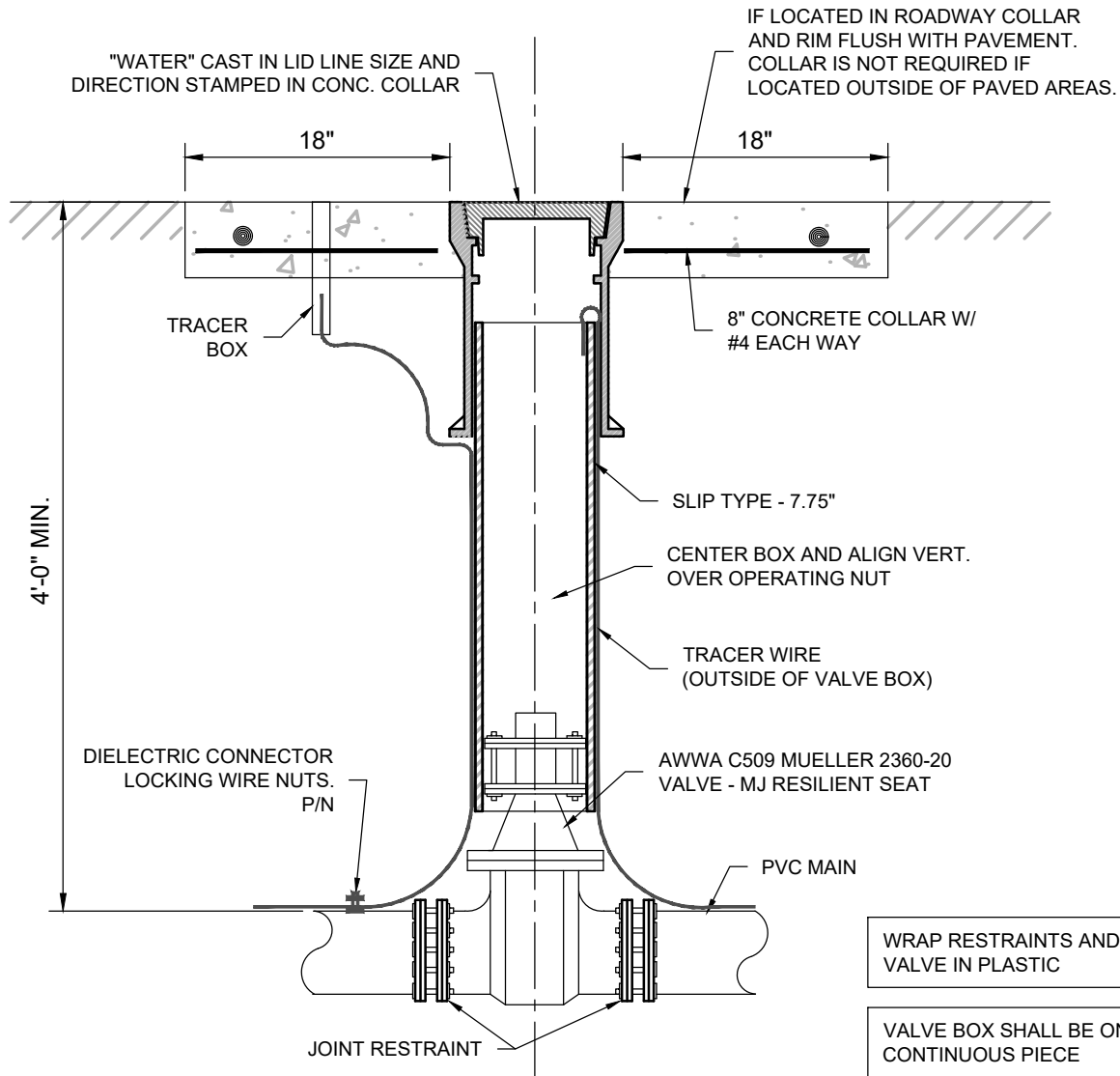

VALVE AND BOX DETAIL

NOT TO SCALE

WHENEVER POSSIBLE LOCATE VALVES OR
 EXTENSIONS OF PROPERTY LINES

LOCATOR WIRE SHALL BE INSTALLED IN THE TRACER BOXES

WRAP RESTRAINTS AND
 VALVE IN PLASTIC

VALVE BOX SHALL BE ONE
 CONTINUOUS PIECE

SHORTY VALVE BOX NO. 70 AS
 MANUFACTURED BY WEST IRON
 WORKS, OR APPROVED EQUAL

TRAFFIC TYPE, MUELLER SUPER CENTURION 250 OR CLOW MEDALLION MODEL NUMBER 2545.
 A FLANGE x MJ GATE VALVE SHALL BE PROVIDED WITH THE HYDRANT.

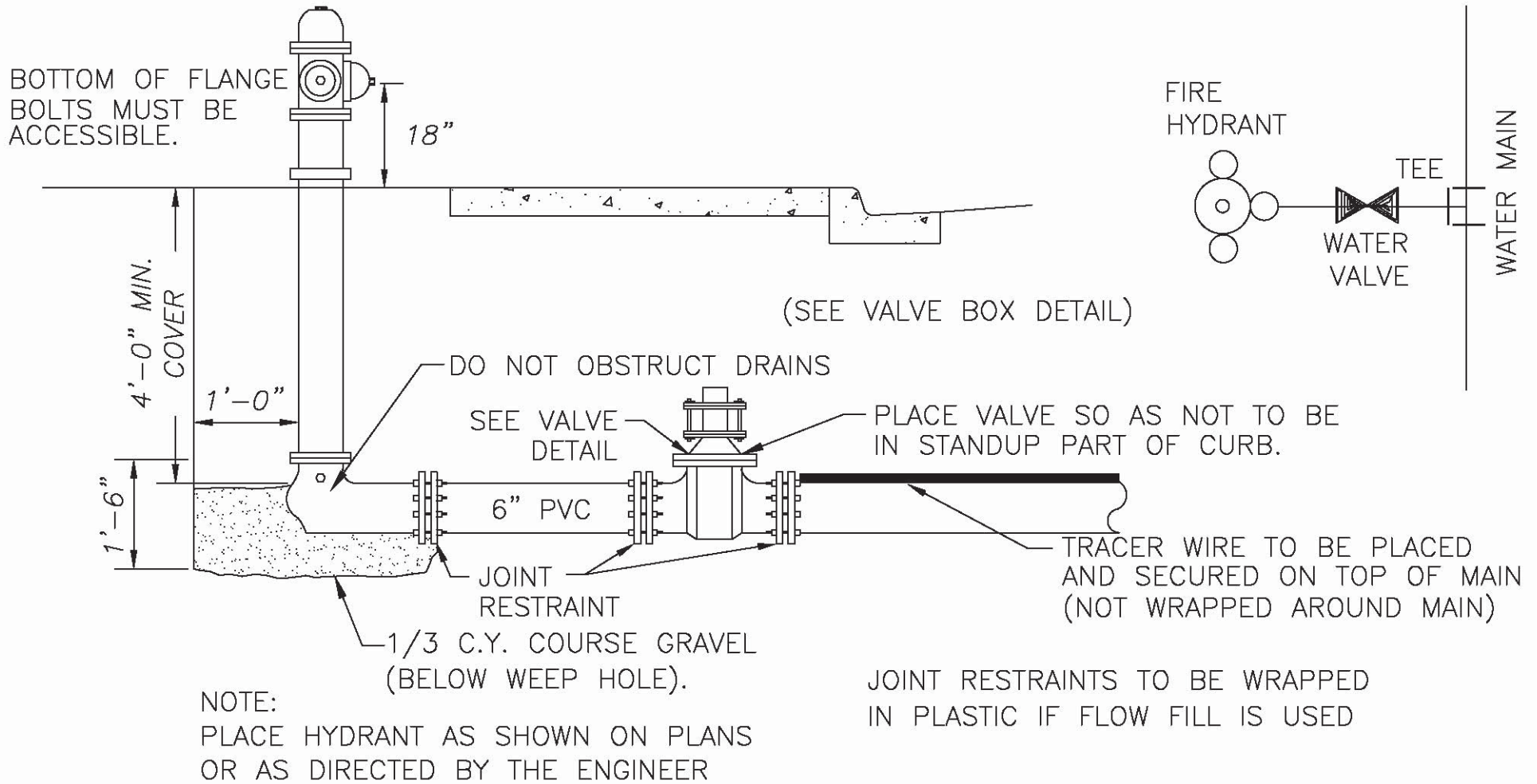

FIRE HYDRANT INSTALLATION

ARTICLE 11
SANITARY SEWER LINES

1. General

- a. This section addresses the furnishing and installing all piping, fittings, service connections, temporary connections, bypass pumping, utility line location, flushing and cleaning the pipe, air and water testing, infiltration testing, removal and plugging of existing sewer pipeline, deflection testing, lamping, coordination with utility owners, and all other labor, material, and equipment inherent to complete construction of gravity sewer system. The construction and materials shall conform to the NMSSPWC Standard Specifications except as modified herein.
- b. All materials shall be new and unused and used in such a manner as to produce completed construction which is authorized and acceptable in every detail. Only materials conforming to the requirements of these specifications will be accepted and used in the work. Materials shall be stored so as to insure the preservation of their quality and fitness for the work.
- c. All sanitary sewer service shall be by gravity flow. Lift stations are not permitted unless approved by the City of Carlsbad Utilities Director.

2. Materials

- a. All materials shall be new and as specified in the contract. Contractor shall include shop drawings and include pertinent technical information and specifications for all items to be furnished. Contractor shall provide the City with certification from the manufacturers for all materials, which attest compliance with appropriate NMSSPWC Standard Specifications or as modified herein. Shop drawings and certifications must be submitted to and approved by the City of Carlsbad prior to installation.
- b. Sanitary Sewer Mains. All gravity sanitary sewer mains shall be constructed of Polyvinyl Chloride Pipe (PVC), SDR 35, push-on gasketed sewer pipe. A minimum pipe size of 8" is required.
 - i. PVC pipe shall meet the requirements of ASTM D 3034 for pipe sizes 8 inches through 15 inches diameter. Minimum wall classifications shall be SDR 35. Only solid wall pipe will be acceptable.

- ii. PVC pipe shall meet the requirements of ASTM F 679 for pipe sizes 18 inches through 27 inches. Minimum pipe stiffness shall be 46 psi. Only solid wall pipe will be acceptable.
- iii. All PVC pipe shall be coded to eliminate future confusion and prevent accidental damage to or interruption of the water and sanitary sewer facilities.
- iv. All joints, gaskets, seals, and connecting devices and materials required to construct sewer lines and to connect manholes, wet wells and services shall meet or exceed requirements of the NMSSPWC Standard Specifications or as modified herein.
- v. Sanitary Service Lines shall be constructed of Polyvinyl Chloride Pipe (PVC), SCH 40. A minimum pipe size of 4" is required.

3. Construction Requirements

- a. Pipe Embedment. Bottom of trench shall be over excavated for all pipes 16" in diameter and larger and the pipe shall be bedded with compacted granular bedding material. The bedding for all other pipe shall be native soils, free of all rock and debris. The bedding shall be properly graded to conform with the required slope and invert elevations. The bedding shall provide uniform support for the entire pipe barrel. The bedding shall be properly excavated to accommodate pipe bells and couplings.
- b. Bedding Material and Thickness. The bedding material shall be a homogeneous granular material. Contractor shall submit a sample for approval to the City of Carlsbad at least two (2) weeks prior to commencement of pipe operations. The granular bedding shall be a minimum of 4 inches in depth for pipe sizes 27 inches and smaller. The bedding depth for pipe sizes greater than 27 inches shall be a minimum 1/8th the pipe O.D.
- c. Upon installation of pipe, select backfill material shall be placed and compacted to an elevation of 12 inches above the top of PVC pipe before native or other backfill material operations can be utilized. For pipes 16" and larger, select backfill shall be granular bedding material. Select backfill for pipes smaller than 16" in diameter can be native soils or other backfill material, totally free of rocks or debris. See paragraph "O" for flow fill requirements.

- d. Installation of Pipe. Pipe, connections, and appurtenances will be placed in accordance with NMSSPWC and manufacturer's recommendations. All pipe joints shall be laid with the bells jointing pointing upstream of the flow. All pipes shall be placed and constructed to meet lines and grades shown on plans.
- e. Service Lines. The Contractor shall connect or maintain existing sewer services as required. Service connections shall be made in accordance with local and state plumbing codes. New connections to existing main lines shall be connected with a saddle. New service lines to new main lines shall be connected using a wye "Y" connection.
- f. By-pass Pumping and Fluming. The Contractor, as required, will by-pass pump or flume the sewage while laying new pipe or making new connections. By-pass pumping will be from manhole to manhole. Prior to fluming, the Contractor shall clean the downstream pipe of all debris.
- g. Connections. Sewer pipe connections to manholes shall be leak-proof. The connections and sealing method shall be as approved by the City of Carlsbad.
- h. Plugging an Abandoned (or to be abandoned) Existing Sewer Line. Contractor shall seal off pipes as shown on plans with a one foot mortared brick plug. Said plug shall be leak-proof. Exposed surfaces shall be treated for protection from gaseous environment as directed by the City of Carlsbad.
- i. Line Locator Placement. Metallic tracer tape shall be placed along the centerline of all sewer lines at a depth of 2 feet below ground surface or 1 foot below top of subgrade when constructed under a roadway. Electronic locator devices will be placed as directed by City of Carlsbad, for stub outs, clean outs, or other appurtenances.
- j. Air Testing. All new gravity sewer pipe 8" in diameter and larger will be leak tested in this manner. Contractor is responsible for all testing and associated costs, including corrective work, if required. This test must be performed after the pipe zone has been backfilled. All testing will be performed under the observation of City of Carlsbad (or designee). The leak test must be performed in accordance with NMSSPWC specifications.
- k. Deflection Testing. Gravity sewer pipe deflection testing may be required at the discretion of the City. The Contractor is responsible for all testing and associated costs, including corrective work, if required. This test must be performed not less than 30 days after the installation and backfill of sewer line. All testing will be performed under the observation of the City of Carlsbad (or designee). Test for deflection will be performed with a mandrel (GO-NOGO

device). The mandrel will be hand pulled. The pipe shall be flushed and cleaned by the Contractor prior to testing. No flow will be permitted in the pipe while testing for deflections. Deflection testing must be performed in accordance with NMSSPWC specifications.

- I. Infiltration Testing. The City of Carlsbad reserves the right to require infiltration testing. If required, this testing, and associated costs, shall be the Contractor's responsibility. Infiltration testing shall be performed in accordance with NMSSPWC specifications.
- m. TV Inspection by Owner. The City may perform an inspection of completed sewer lines prior to placement of lines into service. The Contractor shall advise the City of Carlsbad when ready for TV Inspection. Any defects found will be documented by the City. The Contractor shall be responsible for repairs and associated costs to correct any defects documented. Upon completion of corrective action, the City reserves the right to repeat TV Inspection and process.
- n. Lamping Completed Lines. Before any newly constructed sanitary line is permitted to carry sewage, each line shall be lamped between manholes to determine that its construction conforms to proper grade and alignment and that it is free from obstructions. Ninety percent (90%) of full circle will be considered acceptable.
- o. Flow Fill and Back Fill Requirements. Sanitary sewer lines installed outside of the road prism shall conform to the requirements of Article VIII and as stated above.
 - i. Sanitary sewer lines placed within the road prism shall conform to the requirements of Article VI, and the following requirements:
 - ii. Upon installation of the pipe, regardless of size, granular backfill material such as crusher fines, pea gravel, etc. shall be placed and compacted to an elevation of twelve (12") inches above the top of the pipe.
 - iii. Flow fill material shall then be placed to a minimum depth of "D/3" above the pipe.

- i. Back fill operations shall continue to the top of the subgrade with approved material, with a minimum of compacted eight (8) inch lifts. The Contractor or Developer may submit alternate details for consideration by the City.

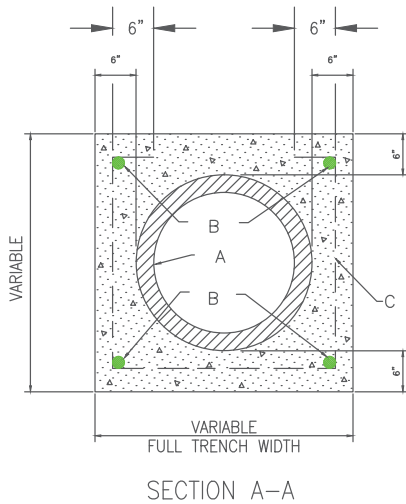
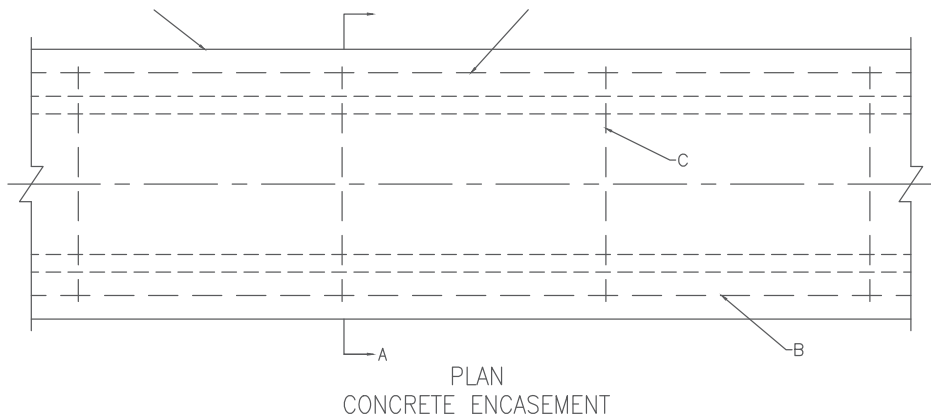

GENERAL NOTES:

1. WHERE A WATER LINE PASSES BENEATH OR LESS THAN 18 IN. ABOVE AN EXIST. SEWER LINE, THE SEWER LINE SHALL BE ENCASED IN CONC. 6" THICK AS DETAILED, FOR AT LEAST 10 FT. ON EACH SIDE OF THE WATER LINE, OR THE SEWER LINE SHALL BE D.I. OR C-900 PVC PIPE WITH PRESSURE-TYPE JOINTS FOR AT LEAST 10 FT. ON EACH SIDE OF THE WATER LINE. THIS SHALL ALSO APPLY WHERE A PARALLEL WATER LINE IS LESS THAN 10 FT. HORIZONTALLY AND LESS THAN 2 FT. ABOVE THE SEWER LINE.

CONSTRUCTION NOTES:

- A. SANITARY SEWER LINE AS SHOWN ON PLANS.
- B. 4- NO. 4 BARS, CONT. WITH 3" CLEARANCE.
- C. NO. 4 BARS, AT 36" O.C.

SEWER ENCASEMENT DETAILS

SCALE: NTS

SEWER LINE DETAILS

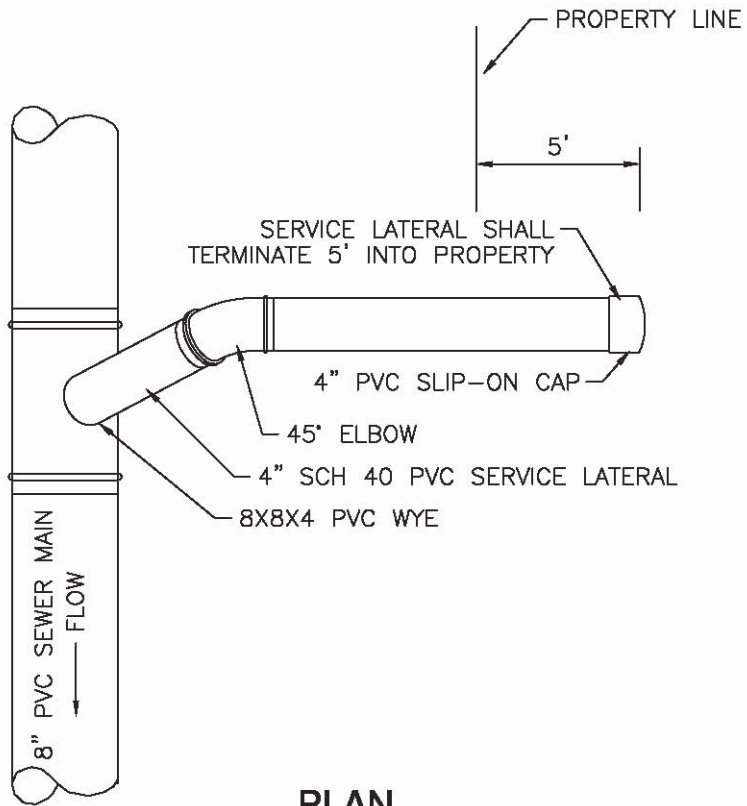

PLAN

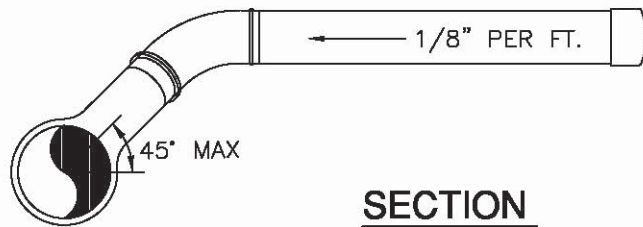
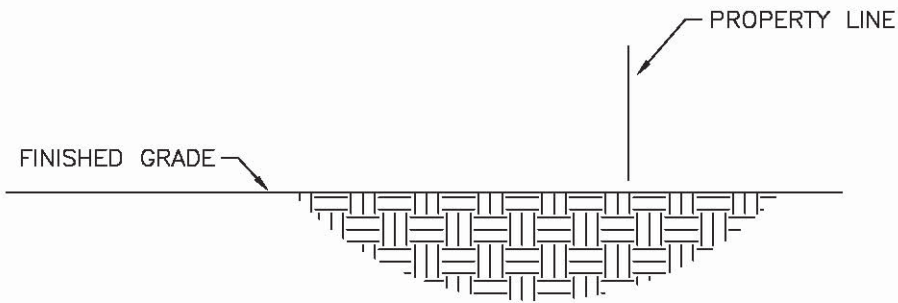

SECTION

TYPICAL SEWER SERVICE LATERAL

CLEAN OUTS MAY BE USED
AT THE END OF A LINE IF
APPROVED BY THE CITY ENGINEER

WESTERN IRON WORKS
CASTING 351800 WITH LID
STAMPED "SEWER"

18" x 6" SQUARE CONCRETE
COLLAR WITH (2) #4 EACH WAY

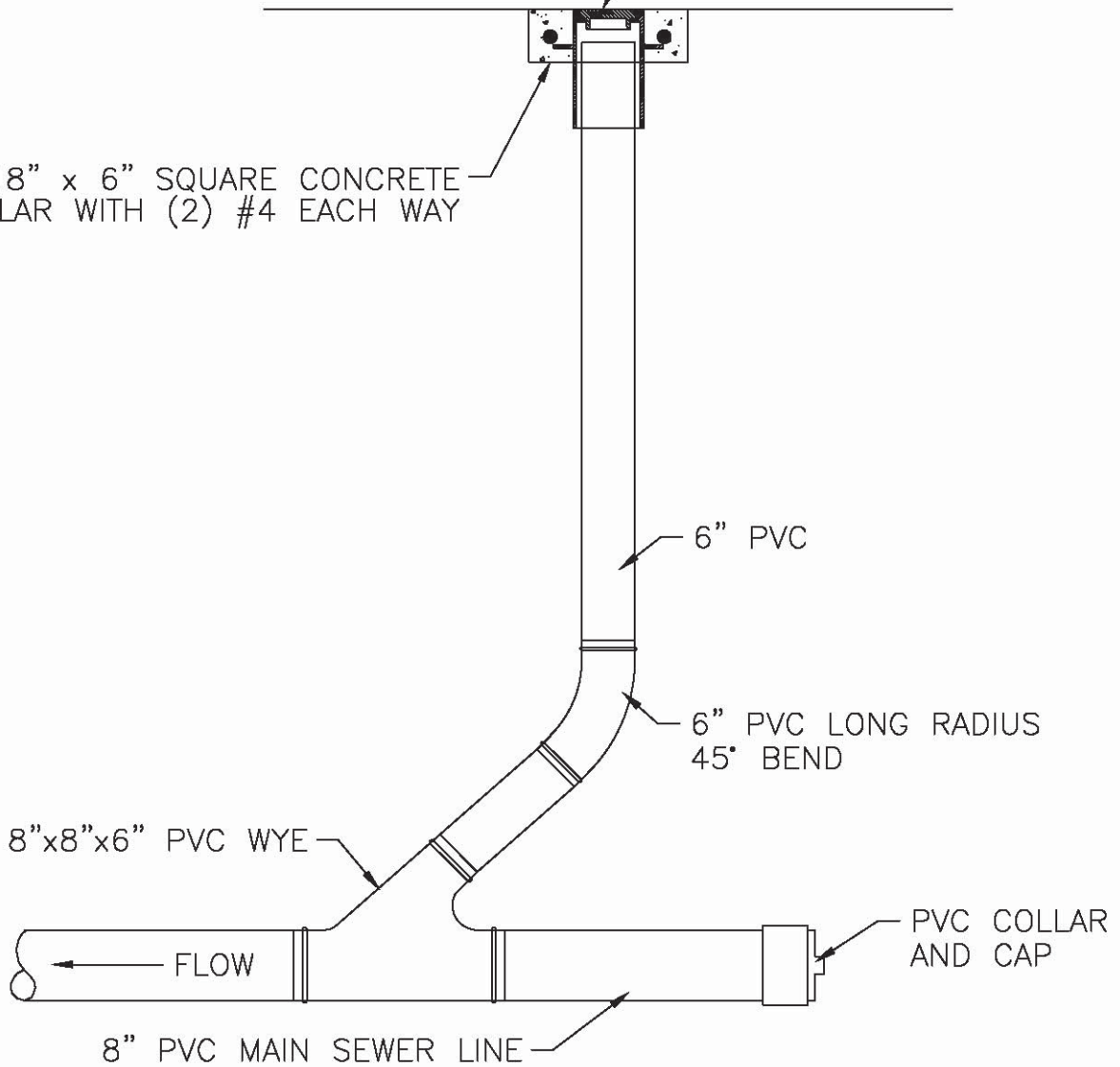

CLEANOUT DETAIL

ARTICLE 12
STANDARD SPECIFICATION FOR MANHOLES

1. General

This section addresses the construction of manholes at the locations and to the lines, grades, dimensions and types as shown in the plans. Manhole construction includes excavation, flowfill, dewatering, temporary plugging of lines, by-pass pumping, concrete, manhole barrels, steel, installation of reducing cones, manhole extensions, ties to existing manholes, ties to existing sewer lines/storm drain systems, manhole adjustments, flat tops, manhole frame and covers, drop connections, protective interior coating/protective lining system, adjustment to grade with concrete collar and testing.

- A. All construction and materials shall conform to these Standard Specifications. Manholes shall be constructed complete with covers, fittings and other appurtenances, in accordance with the details and specifications shown in the City-approved plans or contract.
- B. All manholes shall be constructed of precast reinforced concrete or fiberglass barrels. Manholes shall meet or exceed H-20 load ratings. Contractor shall submit documentation from manufacturer for review and approval by the City of Carlsbad. Manholes shall be constructed complete with covers, steps if called for on plans, fittings and other appurtenances, in accordance with the details and specifications. A minimum 4' diameter, Type "E" Concentric manhole is required unless otherwise approved by the City of Carlsbad.
- C. Manhole Rims and Lids shall be standard cast iron, bottom flange, 325 Pound with a concealed pick slot and vent hole. Western Iron Works # 00120202 or approved equal. The word "Sewer" shall be embossed on the lid.

2. Construction Requirements

- A. The Contractor shall ensure that all operations conform to OSHA requirements. If the Contractor's personnel work in "confined spaces", it will be the Contractor's responsibility to conform with OSHA requirements for working in "confined spaces". Failure to do so will result in shutdown of Contractor's operations, until conformance with OSHA is met.
- B. The installation of reducing cones, manhole extensions, ties to existing manholes, ties to existing sewer lines, manhole adjustments, manhole frame and covers, drop connections, protective interior coating/lining

system and testing shall be performed in accordance with the details shown in the City-approved plans or contract and in accordance with the NMSSPWC Standards.

- C. A flexible pipe-to-manhole connector shall be employed in the connection of the sanitary and storm drain pipe to manholes. The connector shall meet or exceed A.S.T.M. C-923 requirements. The connector shall assure a flexible, watertight seal of the pipe to the manhole.
- D. Maximum spacing between manholes shall be no more than five hundred feet (500').
- E. A protective lining system or interior coating shall be required on all sanitary sewer manholes. The Protective Lining System shall be constructed as follows:

- 1. Concrete Barrel Construction:

Protective Lining System shall be an ultra-high build epoxy coating manufactured by Raven Lining Systems or approved equal. Any substitution will only be allowed if a written request including pertinent data and product information is supplied to the City of Carlsbad for review and approval prior to construction. Contractor will be required to supply material certifications to insure adherence to Protective Lining System called for on plans. Application of system must be performed by trained, certified and experienced personnel and in accordance to manufacturer's recommendations. Typical application thickness shall be a nominal 150 mils thickness (new manhole construction) applied after surface preparation and primer applied as per manufacturer's recommendations. All interior surface areas of the manhole shall be coated, including shelf, inverts, vertical surfaces, manhole rings, adjustment devices, flat tops, etc.

- 2. Fiberglass Manhole Construction:

Fiberglass manholes shall meet or exceed an H-20 load rating. Fiberglass manholes shall meet or exceed all ASTM D3753 standard specifications. The contractor shall be required to supply material certifications to insure adherence to requirements. The contractor shall construct fiberglass manholes in conformance with the manufacturer's recommendations. All non-fiberglass interior surface areas such as the manhole shelf, inverts, vertical surfaces, manhole rings, adjustment devices, flat tops, etc. shall also require application of "Raven 405", "Raven A-6", or equal. Typical application thickness

shall be a nominal 150mils thickness applied after surface preparation and primer is applied, in conformance with the manufacturer's recommendations.

3. Manhole rings and covers shall have "Sewer" embossed on the lid, and shall be from an approved supplier. Unless specified on the plans, Contractor shall furnish new manhole rings and covers.
 4. Concrete shall be minimum Class A, 3000 psi strength, air entrained concrete. All rebar must be minimum Grade 40 or better. All above and other materials shall be new with proper certification of materials.
- F. All sanitary sewer manholes shall be tested for leakage by plugging the inlet and outlet sewer pipes with tight plugs, filling the manhole with water to a depth of four feet above the top of the pipe or two feet above the existing ground water level, whichever is greater, and allowing one hour for saturation of the manhole material. After the one-hour saturation period, the manhole shall be refilled to the original level. Two hours after the refilling, the difference in water surface elevation from original to final level shall be measured and converted into gallons per hour lost through manhole leakage. The allowable leakage for manholes shall be 0.75 gallon per hour per foot diameter of the manhole.

TABLE		
Manhole Diameter (feet)	Allowable Leakage (gallons)	Allowable Difference in Water Surface Elevation (inches)
4'	3.00	0.38"
5'	3.75	0.31"
6'	4.50	0.26"

- G. When plugging an abandoned (or to be abandoned) sewer line, the contractor shall seal off pipes as shown on City-approved plans with a one-foot mortared brick plug. Said plug shall be leak-proof. Exposed surfaces shall be treated for protection from gaseous environment as directed by the City of Carlsbad.

- H. Unless otherwise approved by the City of Carlsbad, the Contractor shall use flowfill for backfilling of all manholes for distance of 3 feet beyond the diameter of the barrel or back to undisturbed soil bank. Flowfill shall be placed in no more than 4 foot lifts every 24 hours. Flowfill shall be from an approved commercial source.

- I. All manhole collars shall be poured in either a round or octagon pattern with reinforcing steel to match the detail.

RIM AND LID TO BE STANDARD CAST IRON, BOTTOM FLANGE,
 325 LB. WITH CONCEALED PICK SLOT AND VENT HOLE REQUIRED.
 WESTERN IRON WORKS MODEL 00120202. LID TO BE EMBOSSED WITH "SEWER."

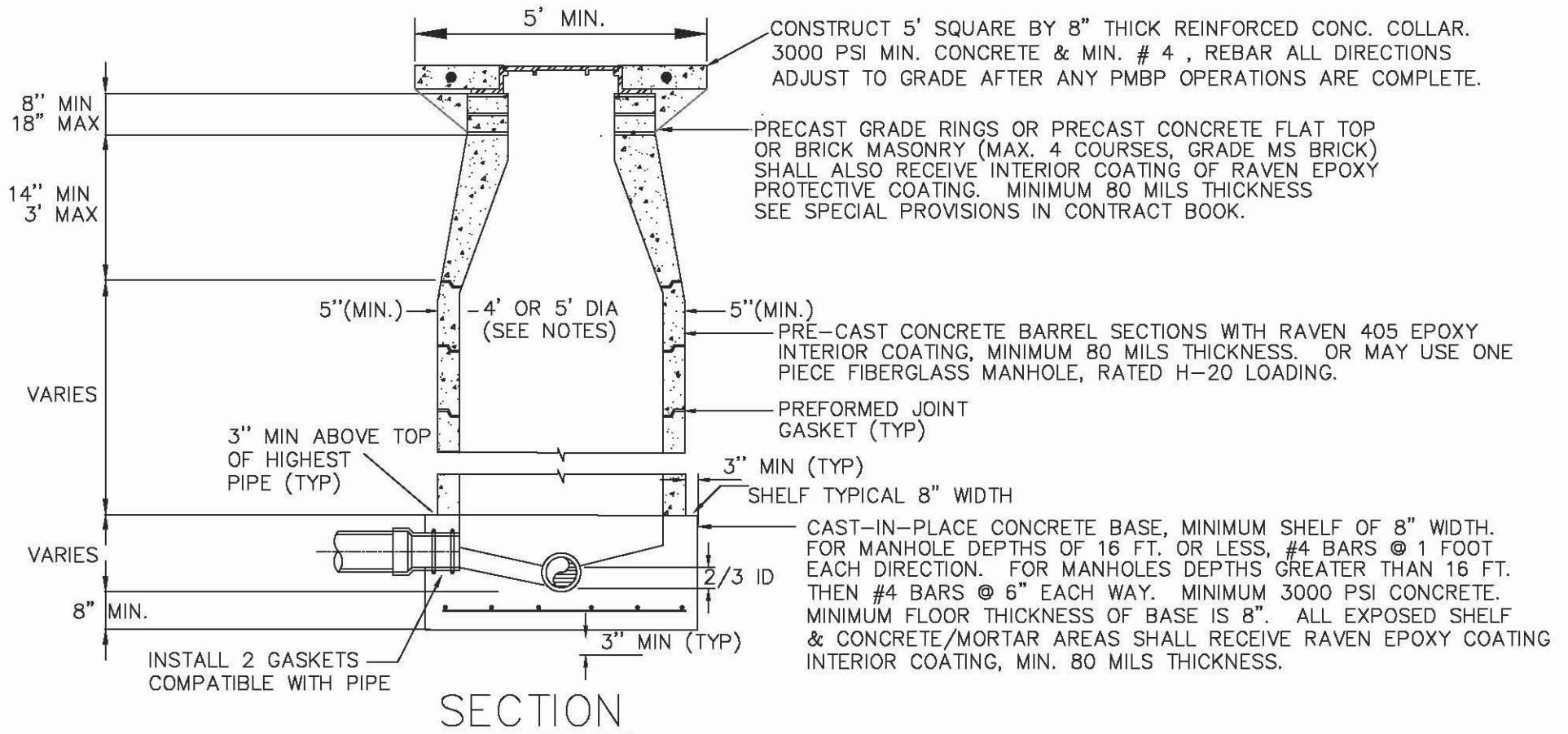

STANDARD SEWER MANHOLE

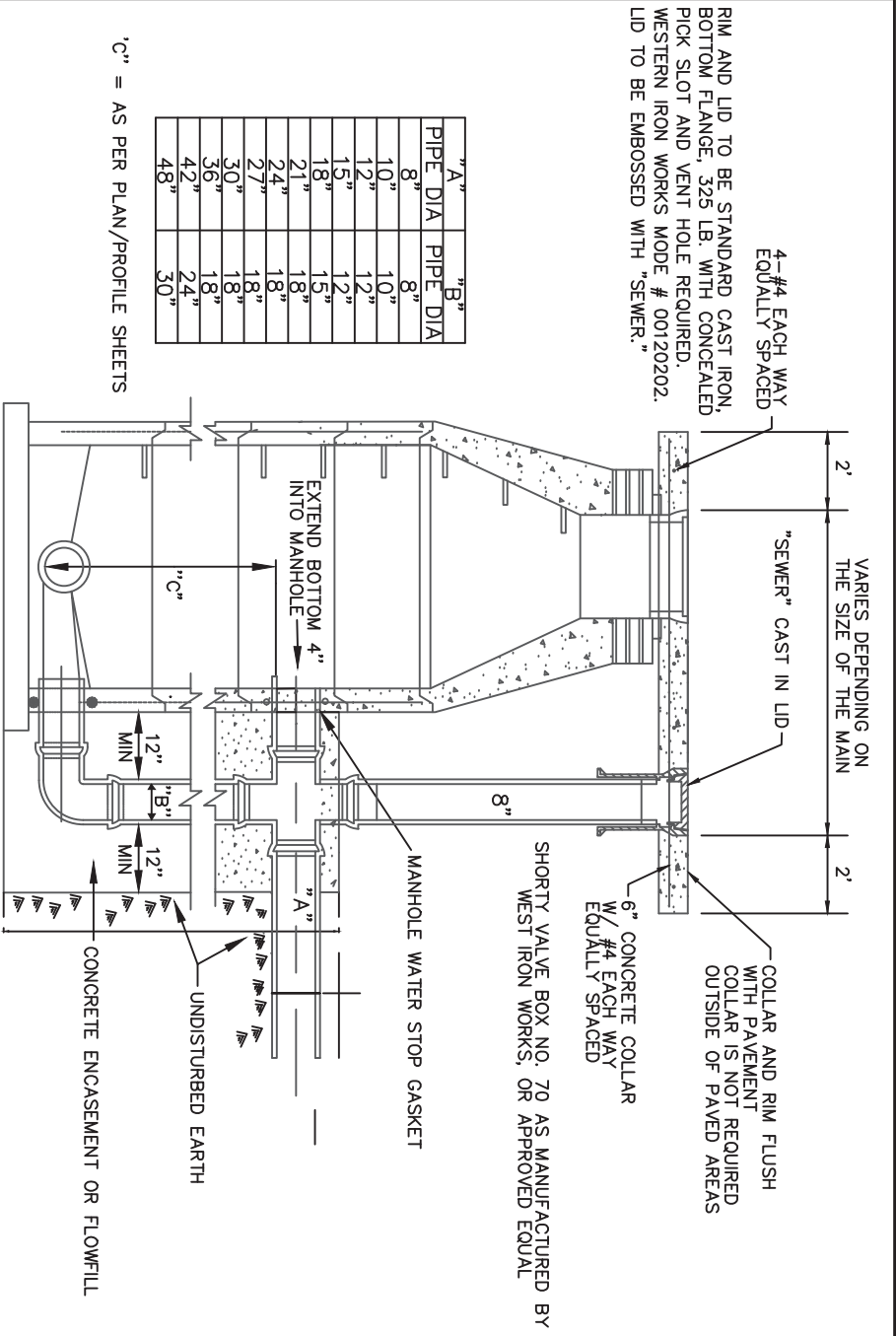

RIM AND LID TO BE STANDARD CAST IRON,
BOTTOM FLANGE, 325 LB. WITH CONCEALED
PICK SLOT AND VENT HOLE REQUIRED.
WESTERN IRON WORKS MODE # 00120202.
LID TO BE EMBOSSED WITH "SEWER."

"A" PIPE DIA	"B" PIPE DIA
8"	8"
10"	10"
12"	12"
15"	12"
18"	15"
21"	18"
24"	18"
27"	18"
30"	18"
36"	18"
42"	24"
48"	30"

'C' = AS PER PLAN/PROFILE SHEETS

ALL MANHOLES TO BE FIBERGLASS OR PRE-CAST CONCRETE WITH INTERIOR COATING.

STANDARD DROP MANHOLE DETAIL

ARTICLE 12

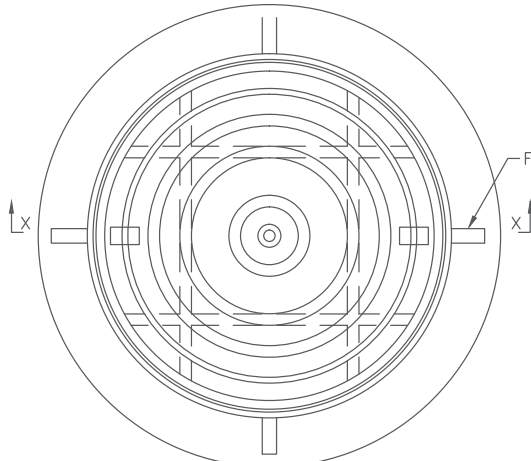

PLAN

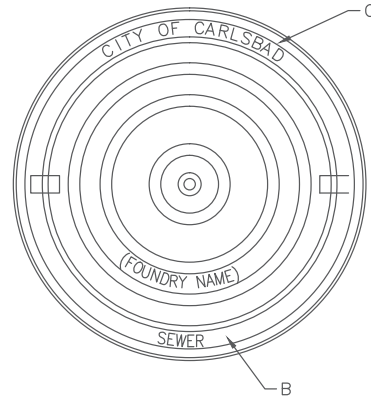

LETTERING PLAN

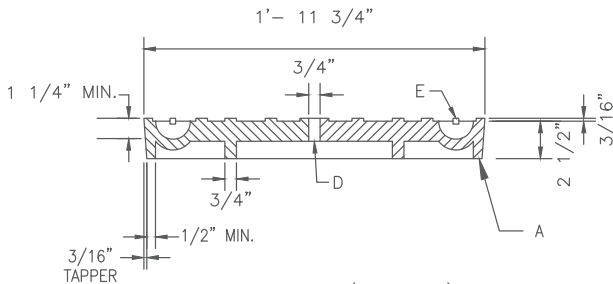

SOLID COVER (180 LB.)

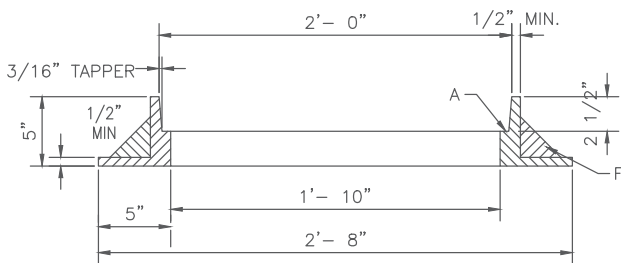

FRAME SECTION X-X

GENERAL NOTES:

1. STANDARD CAST IRON M.H. FRAME AND COVER. WEIGHTS: COVER = 180 LBS., FRAME = 145 LBS. TOTAL = 325 LBS. (TOLERANCE = ±5%)
2. REFERENCE SPEC. SECTION 130.

CONSTRUCTION NOTES:

- A. MACHINED OR GROUND BEARING SURFACES.
- B. "SEWER", "WATER", OR "STORM" CAST ON COVER TO IDENTIFY SANITARY SEWER, WATER OR STORM DRAINAGE SYSTEMS RESPECTIVELY.
- C. LETTER SIZE TO BE 1" MIN. IN HEIGHT, TYPICAL.
- D. VENT HOLE REQUIRED.
- E. MONOLITHIC CAST IRON OR STEEL ROD INSERTS AT MANUFACTURER'S OPTION. IF INSERT IS PROVIDED IT MUST HAVE 3/16" MIN. COVER AND 3/4" END EMBEDMENT IN CASTING.
- F. GUSSETS OPTIONAL IF REQUIRED BY MANUFACTURER.

FRAME & COVER DETAIL

4' CONCRETE WITH REBAR GRID

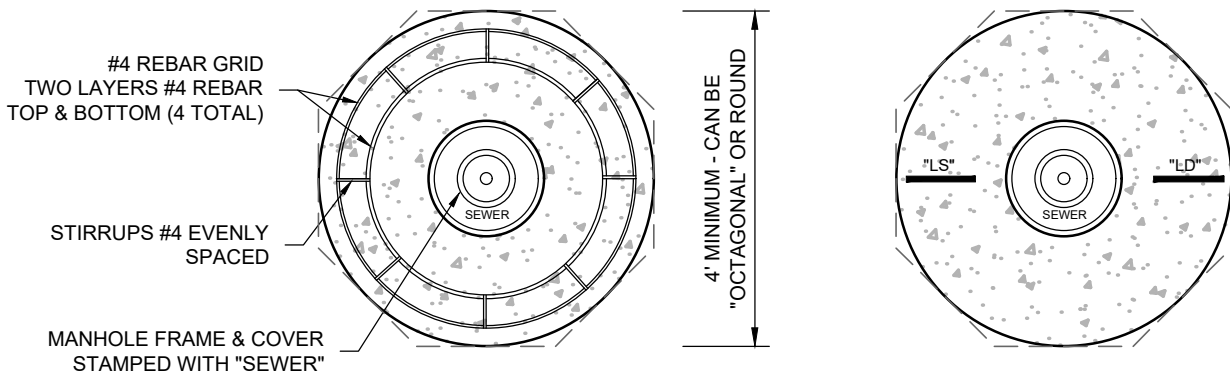

PLAN

"LS" = LINE SIZE
 "LD" = LINE DIRECTION (6" LONG x 1/2" WIDE)
 TOP OF CONCRETE COLLAR SHALL BE STAMPED WITH LINE SIZE AND LINE DIRECTION.
 MINIMUM LETTER SIZE SHALL 3" IN HEIGHT.

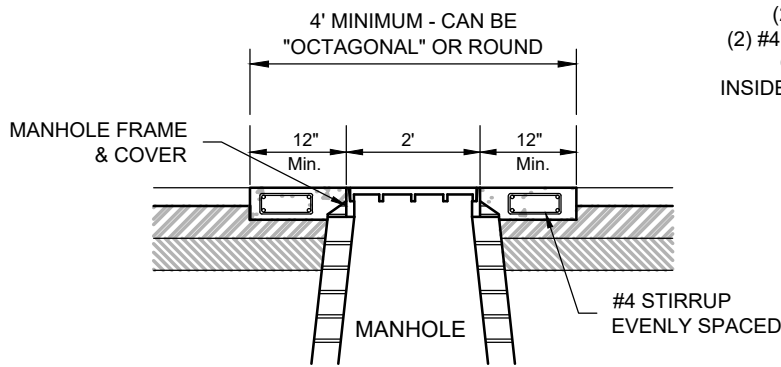

REBAR SECTION

(2) #4 REBAR TOP (1-1/2" CLEAR)
 (2) #4 REBAR BOTTOM (1-1/2" CLEAR)
 OUTSIDE BARS - 2" SIDE CLEAR
 INSIDE BARS - 6" FROM OUTSIDE BAR

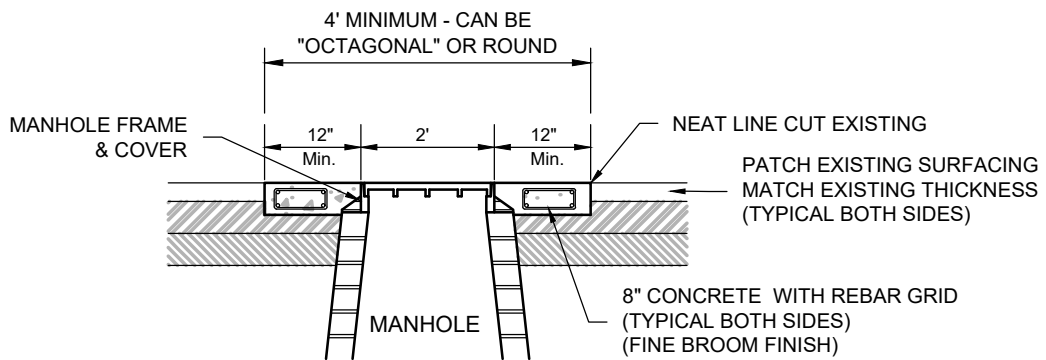
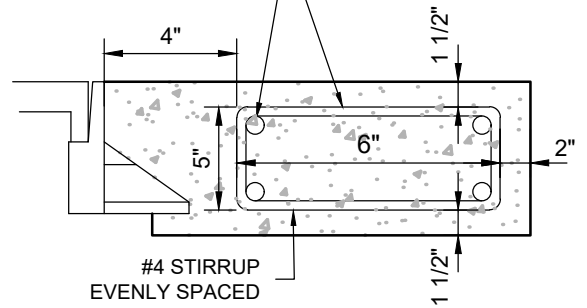

PAVEMENT SECTION

ADJUST MANHOLE TO GRADE

ARTICLE 13
POLICY ON FIRE LINE SYSTEMS

1. General

- A. Fire line systems shall be unmetered and shall comply in all respects to the latest revision of the International Fire Code and the International Building Code currently being used by the City.
- B. The entire fire protection system shall belong to and be the responsibility of the property owner.
- C. Fire protection systems shall be approved by the City of Carlsbad Fire Marshall prior to the issuance of a building permit.
- D. After the Contractor secures the required permits from the City of Carlsbad, the City will tap the water main and install the fire line to the right-of-way line. The City will then charge the contractor/developer for time and materials.

ARTICLE 14
STANDARD SPECIFICATIONS FOR
EXTERIOR LIGHTING

1. *General*

Section 56-120 of the City's Zoning Ordinance No. 2011-15 shall govern the use and requirements for exterior lighting.

The developer shall make provisions for the installation of exterior street lighting with nominal spacing of one (1) light fixture every three hundred (300) linear feet, unless an alternative lighting plan is approved by the City of Carlsbad. For local streets, less than three hundred (300) linear feet, street lighting will be installed at all intersections and at the end of a cul-de-sac.

All "new" street lighting shall be served by underground electrical lines unless otherwise approved by the City. The developer shall pay the cost for installation of a "complete" and workable lighting system. This shall include coordination with the local electrical provider and the City's Planning Director.

Upon acceptance, the City (or the City's contractor) will assume the operation and maintenance of the lighting system.

2. *Night Sky Protection Act*

All lighting systems shall comply with the State of New Mexico's "Night Sky Protection Act", [74-12-1 NMSA 1978].

ARTICLE 15
STANDARD SPECIFICATIONS FOR
STORM DRAINAGE

1. General

This section addresses the guidelines and minimum standards for storm drainage systems and/or storm flow routing, design, and methodology for all projects within the City of Carlsbad. The criteria presented here is intended to be applied to local facilities only. Local facilities are those designed by and constructed by developers or local property owners, and which serve an area smaller than fifty (50) acres.

- A. A Drainage and Grading Permit is required prior to commencement of any site grading. Permits are available in the Planning, Engineering and Regulation Department or on the City's website. The City Engineer reviews and approves these permits and is the point of contact for questions related to drainage and grading within the City.
- B. All grading and drainage changes or improvements shall conform to the City's Drainage Master Plan. For sites equal to and greater than fifty (50) acres, the City shall determine design parameters for drainage facilities, on a case-by-case basis.
- C. All developments/improvements shall not increase the downstream flows and the difference between the pre and post development runoff shall be detained and released as follows:
 - 1. Retention facilities are not permitted. Storm flows and detention facilities must be designed to release all flows within a seventy-two (72) hour period, following a storm event. Any water standing after the seventy-two (72) hour period shall be pumped or otherwise removed.
 - 2. Individual commercial site developments that meet the Drainage and Grading Permit requirements will have detention facilities designed for a ten (10) year storm event. Public infrastructure and subdivisions shall require detention facilities designed to accommodate a twenty-five (25) year storm event.
- D. In general, storm drainage systems, detention facilities, and storm flow routing for all projects shall be designed to:
 - 1. Maintain developed flow discharge rates equal to or less than pre-development rates; and

2. Minimize the increase in the rate of flow discharging from newly developed properties through the use of detention facilities; and
3. Limit point flows discharging at property lines from new developments to non-erosive velocities and controlled depths of flow; and
4. Maintain natural drainage paths unless the natural drainage path conflicts with paragraph 5.
5. Storm flows from the developed site shall be directed to public rights-of-ways or easements. Any storm flows routed to private property, off the site, shall require a private easement or other agreement. A copy of this easement or agreement shall be provided to the City Engineer.

2. *Drainage Analysis Criteria*

- A. Runoff Analysis Methods: Runoff shall be computed in accordance with the Rational Method. Runoff coefficients are shown in Table I and II.
- B. Design Storm Frequency: Facilities shall be designed to provide protection against both minor storms and major storms. Minor storms are defined as those with a 10-year return frequency. Major storms are defined as those with a 100-year return frequency.
- C. Design Storm Intensity: The rainfall intensity is the rainfall rate in inches per hour at a duration equal to the time of concentration. Rainfall Intensity-Duration-Frequency data shall be derived from the NOAA Atlas 14 Point Precipitation Frequency Estimates: New Mexico for the longitude and latitude for the project site.

TABLE I
Rational Method Runoff Coefficients

Categorized by Surface	
Forested	0.059 - 0.2
Asphalt	0.80
Brick	0.75
Concrete	0.85
Shingle Roof	0.75 - 0.95
Lawns, Well Drained (Sandy Soil)	
Up to 2% Slope	0.07
2% to 7% Slope	0.12
Over 7% Slope	0.17
Lawns, Poor Drainage (Clay Soil)	
Up to 2% Slope	0.15
2% to 7% Slope	0.20
Over 7% Slope	0.30
Driveways, Walkways	0.80

TABLE II
Rational Method Runoff Coefficients

Categorized by Use	
Farmland	0.05 - 0.3
Pasture	0.05 - 0.3
Unimproved	0.1 - 0.3
Parks	0.1 - 0.25
Cemeteries	0.1 - 0.25
Railroad Yard	0.2 - 0.4
Playgrounds (except asphalt or concrete)	0.15 - 0.30
Business Districts	
Neighborhood	0.5 - 0.7
City (Downtown)	0.7 - 0.95
Residential	
Single Family	0.3 - 0.5
Multi-plexes, detached	0.4 - 0.6
Multi-plexes, attached	0.6 - 0.75
Suburban	0.25 - 0.4
Apartments, Condominiums	0.5 - 0.7
Industrial	
Light	0.5 - 0.8
Heavy	0.6 - 0.9

TABLE III
Manning's Roughness Coefficients

SURFACE	MANNING'S N VALUE
PVC Pipe	0.010
Smooth Concrete (Trowel Finish)	0.013
Ordinary Concrete Lining	0.014
Vitrified Clay	0.015
Brick with Cement Mortar	0.014
Cast Iron	0.015
Corrugated Metal Pipes	0.023
Cement Rubble Surface	0.024
Short Grass	0.015
Dense Grass	0.024
Bermuda Grass	0.041
Cultivated Soils (Residue Cover < 20%)	0.060
Cultivated Soils (Residue Cover > 20%)	0.170
Rangeland	0.130
Earth Channel (Straight and uniform)	0.023
Earth Channel (Coarse gravel; wav banks)	0.025
Earth Channel (Rough stony beds, irregular sections, weeds)	0.030
HDPE (smooth wall) Pipe	0.009

3. Hydraulic Criteria

- A. Although the primary use of streets shall be for the conveyance of traffic, streets can be used to convey storm runoff with the following limitations:
1. Minor Storm
 - a. Arterial Streets - Two 12 foot wide driving lanes (one in each direction) shall be clear of water and The depth of flow at intersections with other streets shall be less than or equal to six (6) inches;
 - b. Local and Collector Streets - The depth of flow at the gutter flow line shall be less than or equal to six (6) inches.
 2. Major Storm
 - a. The product of the flow depth (feet) at the gutter flow line times the average flow velocity (feet per second) shall be less than or equal to eight (8)
 - b. The depth of flow at the gutter flow lines shall be less than or equal to one (1) foot
 - c. The transverse street flow depth on through traffic streets shall be less than or equal to one (1) foot.
 - d. Flows must be contained within the street right-of-way.
- B. Open Channels: Channel capacities shall be computed using the Manning Formula for uniform flow. Values of the Manning “n” coefficient are shown in Table III. All channels shall be designed with proper and adequate erosion control features.
- C. Storm Drains and Inlets: Storm drains and inlets shall be provided when flows exceed allowable street capacities and at locations where ponding of water is likely to occur if adequate facilities are in place to serve the storm drain. The Manning formula shall be used to compute capacity and velocity of flows within storm drains. The average full-flow velocity shall not be less than two feet/second. Pipes shall not be smaller than 18" diameter. Computations for storm drain and inlet design capacities shall be submitted to the City of Carlsbad.

4. Detention Facilities

A. General:

1. To limit runoff rates to pre-development levels, storm water facilities shall be provided. Detention facilities can include landscaped areas, parking lots, roof top storage, constructed basins, or suitable combinations thereof.
2. Detention facilities shall be designed to accommodate any offsite runoff entering the development. Those developments immediately adjacent to specific major drainage ways, or existing storm drainage systems, if the analysis shows no major impacts on downstream flows, may have detention requirements waived, subject to the approval of the City of Carlsbad. Developments where post development rates are less than pre-development rates, may be exempt from detention requirements, subject to the approval of the City of Carlsbad.

B. Design Method:

1. Inflow Hydrograph - The calculated inflow hydrograph, in combination with the maximum outlet flow, determines the required detention storage volume. Using the Rational Method, a triangular inflow hydrograph can be constructed using the following assumptions:
 - a. Peak flow occurs at the "time-of-concentration" (t_c)
 - b. Flow increases linearly from
 $Q = 0$ to $Q = Q_{\text{peak}}$ for $t = 0$ to $t = t_c$
 - c. Flow decreases linearly from
 $Q = Q_{\text{peak}}$ to $Q = 0$ for $t = t_c$ to $t = 2(t_c)$
 - d. Inflow rates shall be calculated using a 24 hour, 25-year storm under developed conditions
2. Outflow Limitations - The maximum outlet capacity shall be calculated using a 24 hour, 10-year storm and existing conditions.
3. Volume Calculation - After the inflow hydrograph and outflow rating curve have been determined the required storage volume can be calculated as follows:

$$V = 60(T_c)(Q_I)(1 - Q_o / Q_I)$$

T_c = Time of Concentration (min)

Q_I = Peak Inflow (cfs)

Q_o = Peak Outflow (cfs)

EXAMPLE

T_c = 15.2 minutes

Q_I = 29 cfs

Q_o = 13 cfs

$$V = 60(15.2)(29)(1 - 13/29) \\ = 14,546 \text{ c.f.}$$

Carlsbad, New Mexico Detention Storage Volume Example

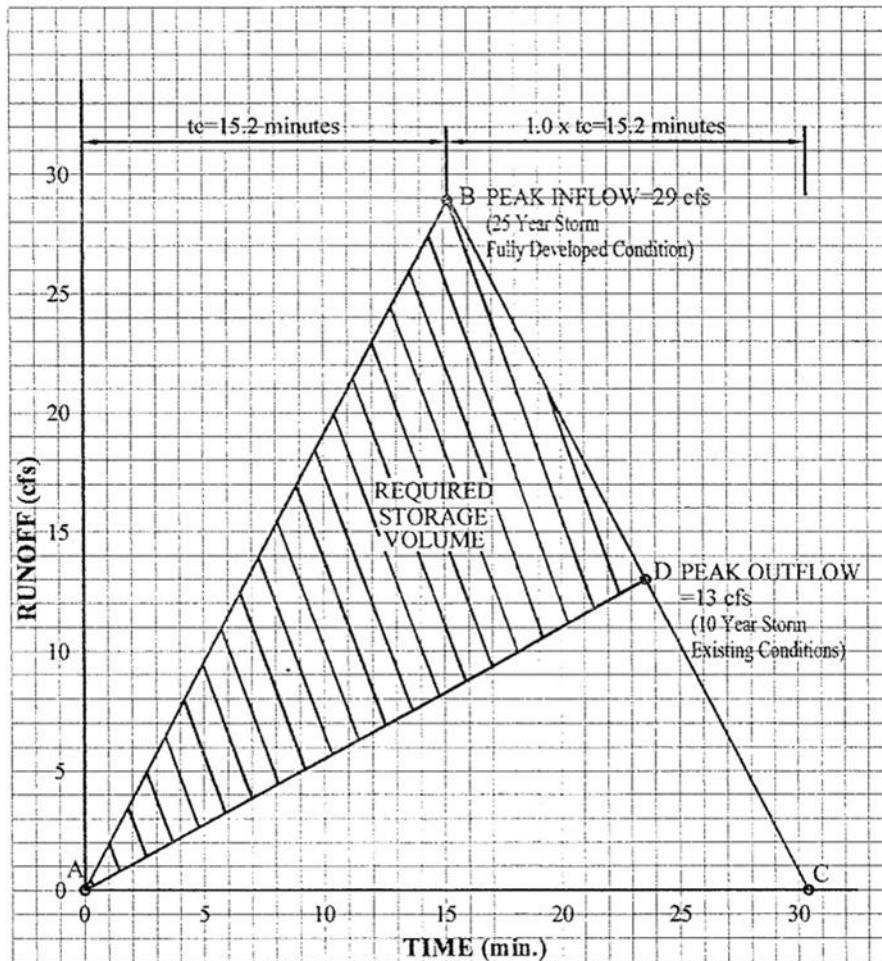

Figure II

5. Submittal Requirements - Residential Subdivisions

A. General

1. All drainage reports shall be prepared by a Professional Engineer Registered in the State of New Mexico.
2. The report shall include a description of the existing drainage patterns within the development as well as a discussion of the proposed storm drainage system for the development, including the detention and stormflow routing options to be used, and the effect of this drainage system on adjacent properties. If requested by the City of Carlsbad, infiltration and absorption tests shall be performed on the site, and recommendations submitted for silt and erosion control.

B. Preliminary Drainage Study

1. A Preliminary Drainage Report shall accompany all applications for Preliminary Plat approval of subdivisions within the City of Carlsbad.
2. The purpose of the Preliminary Drainage Report is to identify major drainage ways, ponding areas, locations of culverts, bridges, open channels and drainage basins which are contributory to the proposed development. In addition, the ability of downstream drainage facilities to pass runoff from the proposed development must be analyzed in the Study.
3. The report shall include, but not be limited to the following information and calculations:
 - a. Calculations for peak flow from all offsite tributary drainage areas.
 - b. Calculations for peak flow within the proposed development.
 - c. Delineation of all flood boundaries delineated on the FEMA Flood Plan Maps and major drainage ways within 200 feet of the proposed development.
 - d. Discussion of stormflow routing within and through the development.
 - e. Discussion and analysis of downstream drainage facilities.
 - f. Hydraulic calculations for all stormflow routing conveyances.
 - g. Report shall be typed and bound on 8½" x 11" paper.

4. Drawings for the Preliminary Drainage Report shall include but not be limited to the following:
 - a. Any and all flood plains and floodways within 200 feet of the proposed development.
 - b. Existing topography and stormflow patterns.
 - c. Location and size of existing and proposed streets, open channels, storm drains, detention areas, and other drainage structures.
 - d. Identification of all existing and post-development drainage basins within the development and tributary to the development.

C. Final Drainage Report - The Final Drainage Report shall be a detailed study and analysis of the drainage in the proposed development. It shall include detailed calculations for all runoff within the proposed development and detailed calculations supporting the design of all drainage structures within the development.

1. A Final Drainage Report shall accompany all applications for Final Plat approval of subdivisions within the City of Carlsbad. A Drainage Report shall also accompany construction drawings submitted for a City Building Permit for the following projects:
 - a. Commercial and industrial developments.
 - b. Multi-family developments greater than three (3) acres in area.
2. Construction plans for all drainage structures, grading plans and street grades where applicable, shall also be considered part of the Final Drainage Report.
3. Drawings and calculations comprising the final drainage study shall include, but not be limited to the following information:
 - a. Existing and proposed contours for the proposed development. (one (1) foot minimum contour interval).
 - b. Locations and elevations of benchmarks.
 - c. Property lines.
 - d. Streets, R-O-W limits, names and grades.
 - e. Existing drainage facilities and structures, including existing irrigation ditches, roadside ditches, drainage ways, gutter flow directions, and culverts. All pertinent information such as size, slope, and location of existing drainage ways shall be included

to facilitate review and approval of drainage plans.

- f. Proposed type of curb and gutter and gutter flow directions.
- g. Proposed storm drains, open drainage ways and right-of-way requirements, including proposed inlets, manholes, culverts, erosion control and energy dissipation devices, and any other required appurtenances necessary for drainage control.
- h. Proposed inflow and outfall point(s) for runoff from the study area.
- i. Routing and accumulative flows at various critical points for the minor (10 year) and major (100 year) storm runoff.
- j. Minimum finished floor elevation and ground site elevations at all critical building locations for protection from major storm runoff.
- k. Proposed phasing of the subdivision or development and the associated storm flow routing or detention facilities.

6. Submittal Requirements – Commercial and Industrial Developments or Subdivisions

A. General

- 1. All drainage reports shall be prepared by a Professional Engineer Registered in the State of New Mexico.
- 2. The report shall include a description of the existing drainage patterns within the development as well as a discussion of the proposed storm drainage system for the development, including the detention and stormflow routing options to be used, and the effect of this drainage system on adjacent properties. If requested by the City of Carlsbad, infiltration and absorption tests shall be performed on the site, and recommendations submitted for silt and erosion control.

B. A Preliminary Drainage Report shall accompany all applications for Final Plat approval of subdivisions within the City of Carlsbad’s five-mile jurisdiction.

- 1. The purpose of the Preliminary Drainage Report is to identify major drainage ways, ponding areas, locations of culverts, bridges, open channels and drainage basins which are contributory to the proposed development. In addition, the ability of downstream drainage facilities to pass runoff from the proposed development must be analyzed in the Study. The report shall include, but not be limited to the following

information and calculations:

- a. Calculations for peak flow from all offsite tributary drainage areas.
 - b. Calculations for peak flow within the proposed development for existing and developed conditions both off site and onsite.
 - c. Delineation of all flood boundaries and major drainage ways within 200 feet of the proposed development.
 - d. Discussion of stormflow routing within and through the development.
 - e. Discussion and analysis of downstream drainage facilities.
 - f. Hydraulic calculations for all stormflow routing conveyances.
 - g. Report shall be typed and bound on 8½" x 11" paper.
 - h. Existing topography and storm flow patterns within 300 feet of the proposed development.
2. Drawings for the Preliminary Drainage Report shall include but not be limited to the following:
- a. Any and all flood plains and floodways within 200 feet of the proposed development.
 - b. Existing topography and stormflow patterns.
 - c. Location and size of existing and proposed streets, open channels, storm drains, detention areas, and other drainage structures.
 - d. Identification of all existing and post-development drainage basins within the development and tributary to the development.
3. The Final Drainage Report shall be a detailed study and analysis of the drainage in the proposed development. It shall include detailed calculations for all runoff within the proposed development and detailed calculations supporting the design of all drainage structures within the development.

4. A Final Drainage Report shall accompany all applications for a City Building Permit.
5. Construction plans for all drainage structures, grading plans and street grades where applicable, shall also be considered part of the Final Drainage Report.
6. Drawings and calculations comprising the final drainage study shall include, but not be limited to the following information:
 - a. Existing and proposed contours for the proposed development (one (1) foot minimum contour interval); and
 - b. Locations and elevations of benchmarks; and
 - c. Property lines; and
 - d. Streets, R-O-W limits, names and grades; and
 - e. Existing drainage facilities and structures, including existing irrigation ditches, roadside ditches, drainage ways, gutter flow directions, and culverts. All pertinent information such as size, slope, and location of existing drainage ways shall be included to facilitate review and approval of drainage plans; and
 - f. Proposed type of curb and gutter and gutter flow directions.
 - g. Proposed storm drains, open drainage ways and right-of-way requirements, including proposed inlets, manholes, culverts, erosion control and energy dissipation devices, and any other required appurtenances necessary for drainage control.
 - h. Proposed inflow and outfall point(s) for runoff from the study area.
 - i. Routing and accumulative flows at various critical points for the minor (10 year) and major (100 year) storm runoff.
 - j. Minimum finished floor elevation and ground site elevations at all critical building locations for protection from major storm runoff.
 - k. Proposed phasing of the subdivision or development and the associated storm flow routing or detention facilities.
 - l. Summary calculations for inlet capacity and gutter flow depth using headwater depth for culverts and culvert capacity, to also include storm sewer HGL and capacity.

Appendix A
City of Carlsbad Contact Information

Mailing Address (for all Departments):

City of Carlsbad
P.O. Box 1569
Carlsbad, NM 88221

Physical Address:

City of Carlsbad – Municipal Building
101 N. Halagueno Street
Carlsbad, NM 88220
(575) 887-1191
(800) 658-2713

Planning, Engineering and Regulation Department
114 S. Halagueno Street
Carlsbad, NM 88220
(575) 885-1185

Utilities Department
1502 W. Stevens St.
Carlsbad, NM 88220
(575) 234-7970

Public Works Department
1702 W. Fox Street
Carlsbad, NM 88220
(575) 234-7970