

SECTION A-A

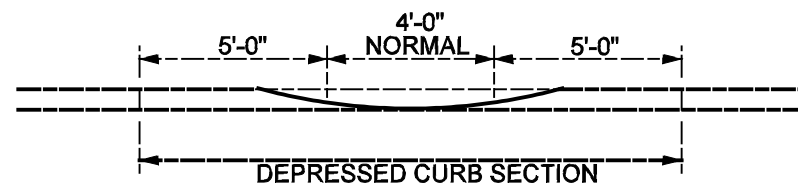

SECTION B-B

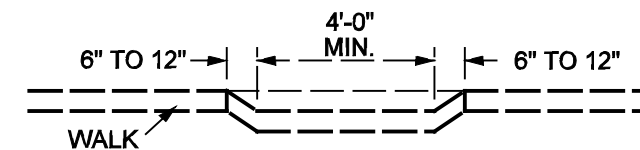
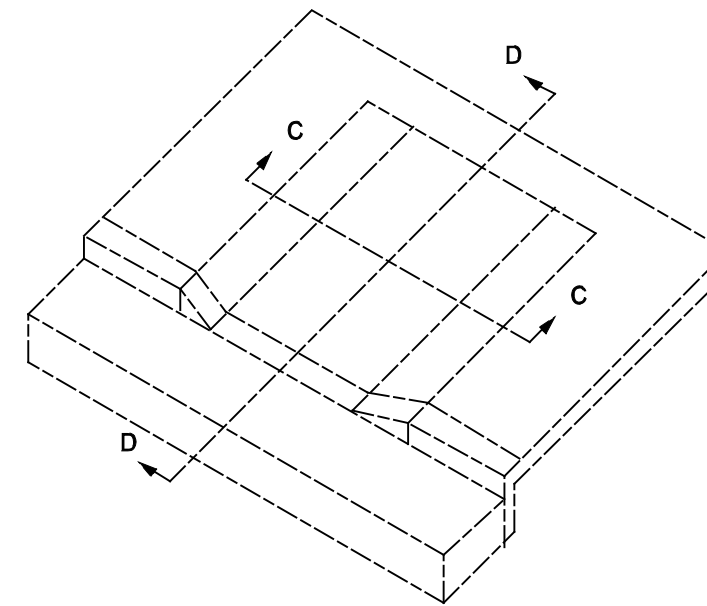

SECTION C-C

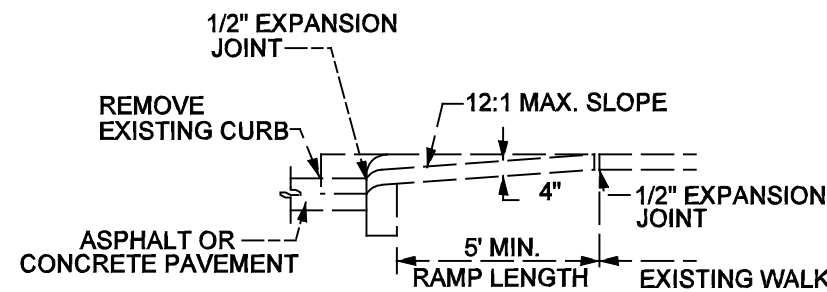

SECTION D-D
IN EXISTING WALK

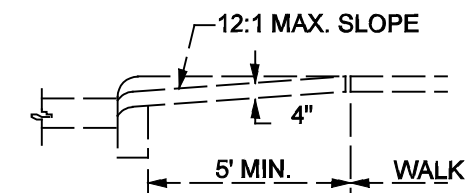

SECTION D-D

NOTES

SURFACE TEXTURE SHALL BE OBTAINED BY COARSE BROOMING TRANSVERSE TO THE RAMP SLOPES AND SHALL BE ROUGHER THAN ADJACENT WALK.

JOINTS SHALL BE PROVIDED IN THE CURB RAMP AS EXTENSIONS OF WALK JOINTS AND CONSISTENT WITH REQUIREMENTS FOR NEW CONCRETE WALK.

A 1/2" EXPANSION JOINT FILLER SHOULD BE PROVIDED AROUND THE EDGE OF RAMPS BUILT IN EXISTING CONCRETE WALK.

ANY COMBINATION OF SIDE SLOPES ON OPPOSITE SIDES OF A RAMP MAY BE USED TO BEST FIT THE SITE CONDITIONS.

THE MINIMUM RAMP LENGTH IS 5' FROM BACK OF A 6" CURB AND MAY BE INCREASED WHERE FEASIBLE TO OBTAIN A FLATTER RAMP SLOPE OR TO BETTER BLEND WITH THE WALK CONFIGURATION.

WALK THICKNESS IN THE RAMP SLOPES SHALL BE 4" MINIMUM OR THICKER AS NECESSARY TO MATCH ADJACENT WALK THICKNESS.