

600 - STORM DRAINAGE

NOTES

A. AS OF JANUARY 1, 2003 THE FOLLOWING TEXT SHALL BE CAST INTO THE TOP OF THE GRATE:
"DUMP NO WASTE" AND **"DRAINS TO WATERWAY"**
 TEXT SHALL BE PRINTED IN BOLD, CAPITAL LETTERS WITH A MINIMUM HEIGHT OF 1/2 INCH. "WATERWAY" MAY BE SUBSTITUTED WITH "STREAM", "RIVER", "LAKE", ETC. ACTUAL PLACEMENT AND LOGO MAY VARY PER MANUFACTURER.

B. CASTING SHALL BE EAST JORDAN 7030 OR NEENAH R-3246 OR EQUIVALENT.

C. FOR TYPE 2 COMBINATION CURB AND GUTTER THE BACK SHALL BE EAST JORDAN TYPE T4 OR NEENAH (3 INCH RADIUS) (R-3246-I).

D. FOR TYPE 1 COMBINATION ROLL CURB AND GUTTER THE BACK SHALL BE EAST JORDAN TYPE T2 OR NEENAH (MOUNTABLE CURB) (R-3246-E).

E. CATCH BASIN IN DRIVE APPROACHES TO BE AVOIDED, IF POSSIBLE. THE BACKS SHALL BE EAST JORDAN TYPE T3 OR NEENAH (R-3246-1 WITH CURB PLATE).

F. STANDARD GRATE SHALL BE EAST JORDAN TYPE M2, NEENAH TYPE C, OR EQUIVALENT. ALL BAR EDGES TO BE ROUNDED 1/8 INCH RADIUS.

G. CONCRETE, CAST-IN-PLACE, TO BE CLASS C. PRECAST CONSTRUCTION PERMITTED AND CONCRETE SHALL MEET THE REQUIREMENTS OF 706.13 WITH 6±2% AIR VOID CONTENT IN THE HARDENED CONCRETE. KNOCKOUTS ARE REQUIRED IN PRECAST CONSTRUCTION. PRECAST WALLS SHALL HAVE A SUFFICIENT AMOUNT OF REINFORCEMENT TO PERMIT SHIPPING AND PLACEMENT WITHOUT DAMAGE.

H. CARE SHALL BE TAKEN WHEN CONNECTING TO AN EXISTING CATCH BASIN TO KEEP OPENING AS MINIMAL AS POSSIBLE. IF POSSIBLE, SAW CUT OR USE ROTARY HAMMER FOR OPENING TO MINIMIZE DAMAGE TO CATCH BASIN. PIPE TO INTRUDE INTO CATCH BASIN 1 INCH ONLY AND PIPE MUST BE CUT PARALLEL TO CATCH BASIN. USE NONSHRINK GROUT AROUND PIPE TO SEAL BETWEEN PIPE AND CATCH BASIN.

I. DROP FLOW LINE 1/2 INCH WITHIN BLOCK OUT OF COMBINED CURB AND GUTTER WHILE KEEPING LIP OF GUTTER CONSISTENT WITH TOP OF CURB.

J. ALL GRATES SHALL BE CONSIDERED "BICYCLE SAFE".

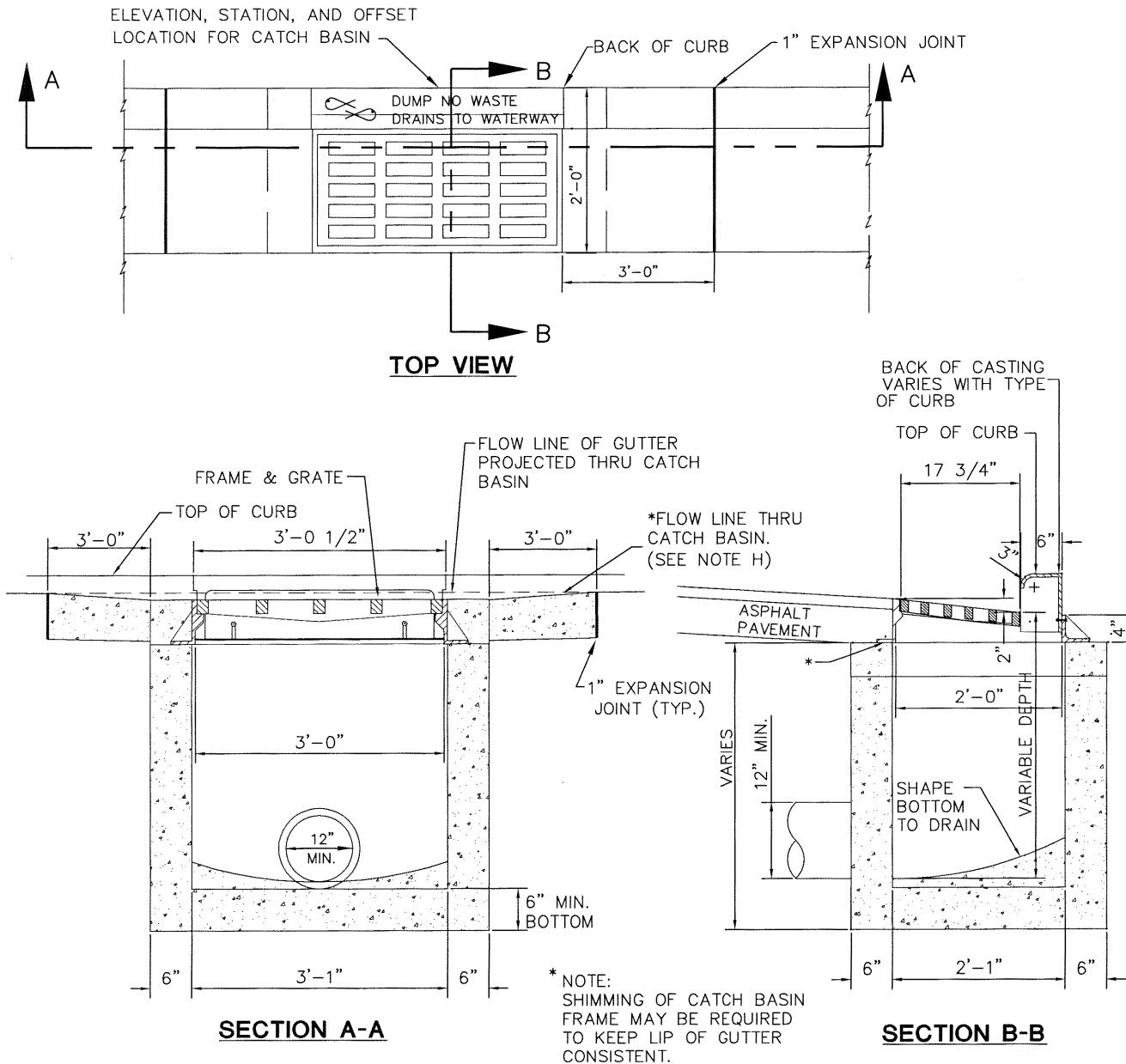

CITY OF
PIQUA

CHOICE
ONE
ENGINEERING

TYPE 1 CATCH BASIN

REVISIONS:	DATE APPROVED: AUG. 2008
	PAGE No. 600-1

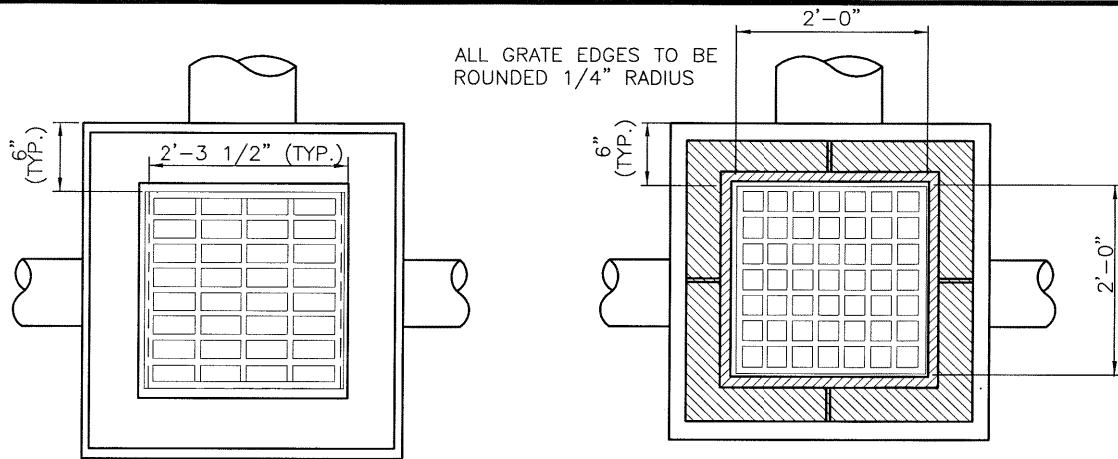

PLAN

PLAN

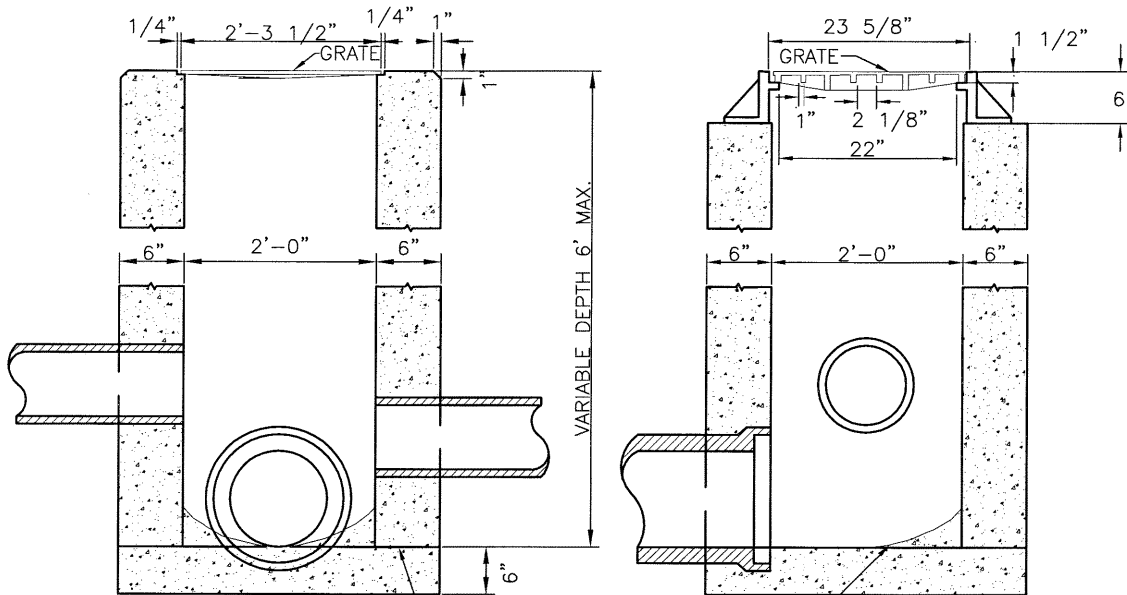

NONPAVED AREAS

PAVED AREAS

BOTTOM SLAB MAY BE CAST SEPARATELY AND THE OUTLET PIPE PLACED ON TOP OF IT WITH THE BOTTOM SHAPED TO DRAIN.

NOTES

- A.** AS OF JANUARY 1, 2003 THE FOLLOWING TEXT SHALL BE CAST INTO THE TOP OF THE GRATE:
"DUMP NO WASTE" AND "DRAINS TO WATERWAY"
 TEXT SHALL BE PRINTED IN BOLD, CAPITAL LETTERS WITH A MINIMUM HEIGHT OF 1/2 INCH. "WATERWAY" MAY BE SUBSTITUTED WITH "STREAM", "RIVER", "LAKE", ETC. ACTUAL PLACEMENT AND LOGO MAY VARY PER MANUFACTURER.
- B.** LOCATION AND ELEVATIONS WHEN GIVEN ON THE PLANS IS TOP CENTER OF THE GRATE. WHEN SIDE OPENINGS ARE PROVIDED, ELEVATION SHALL BE THE FLOW LINE OF THE SIDE INLET.
- C.** GRATE FOR NONPAVED AREAS SHALL BE EAST JORDAN IRON WORKS 5110 TYPE M3 OR NEENAH CATALOG NO. R-4859-C OR EQUIVALENT.
- D.** GRATE ELEVATION TO BE PLACED 4 INCH TO 6 INCH BELOW NORMAL DITCH RETURNING TO NORMAL 10' EACH SIDE OF BASIN.
- E.** PRECAST CONSTRUCTION IS REQUIRED, UNLESS OTHERWISE APPROVED, AND CONCRETE SHALL MEET THE REQUIREMENTS OF 706.13 WITH 6±2% AIR VOID CONTENT IN THE HARDENED CONCRETE. KNOCKOUTS SHALL BE PROVIDED IN PRECAST CONSTRUCTION. PRECAST WALLS SHALL HAVE A SUFFICIENT AMOUNT OF REINFORCEMENT TO PERMIT SHIPPING AND PLACEMENT WITHOUT DAMAGE.
- F.** CATCH BASINS NOT PERMITTED IN PAVEMENT AREAS UNLESS USING A FRAME AND GRATE EQUIVALENT OF NEENAH CATALOG NO. R-3405 OR EAST JORDAN IRON WORKS NO. 5250.
- G.** FOR PIPES OVER 18" REFER TO ODOT CATCH BASIN 2-3 AND 2-4. FOR SIDE INLETS REFER TO ODOT CATCH BASIN 2-2-A.
- H.** CARE SHALL BE TAKEN WHEN CONNECTING TO AN EXISTING CATCH BASIN TO KEEP OPENING AS MINIMAL AS POSSIBLE. IF POSSIBLE, SAW CUT OR USE ROTARY HAMMER FOR OPENING TO MINIMIZE DAMAGE TO CATCH BASIN. PIPE TO INTRUDE INTO CATCH BASIN 1" ONLY AND PIPE MUST BE CUT PARALLEL TO CATCH BASIN. USE NONSHRINK GROUT AROUND PIPE TO SEAL BETWEEN PIPE AND CATCH BASIN.

CITY OF PIQUA

CHOICE ONE ENGINEERING

TYPE 2-2-B CATCH BASIN

REVISIONS: DATE APPROVED: AUG. 2008 PAGE No. 600-2

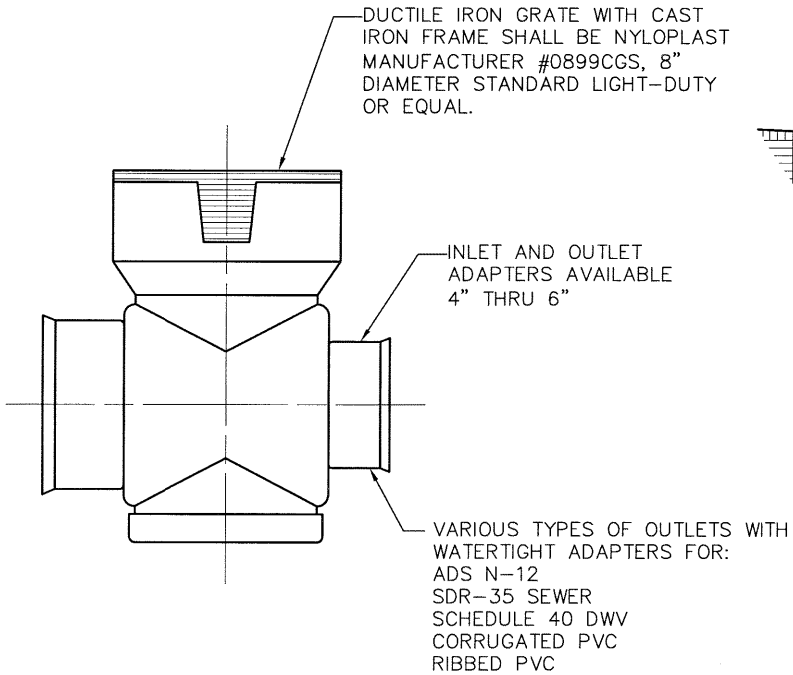

TYPE 2 YARD DRAIN

-STANDARD OR CUSTOM DRAIN BASIN FOR VARIABLE INLET HEIGHT SHALL BE NYLOPLAST MANUFACTURER #2808AG OR EQUAL.

-CONTRACTOR TO INSTALL PER MANUFACTURER'S RECOMMENDATIONS.

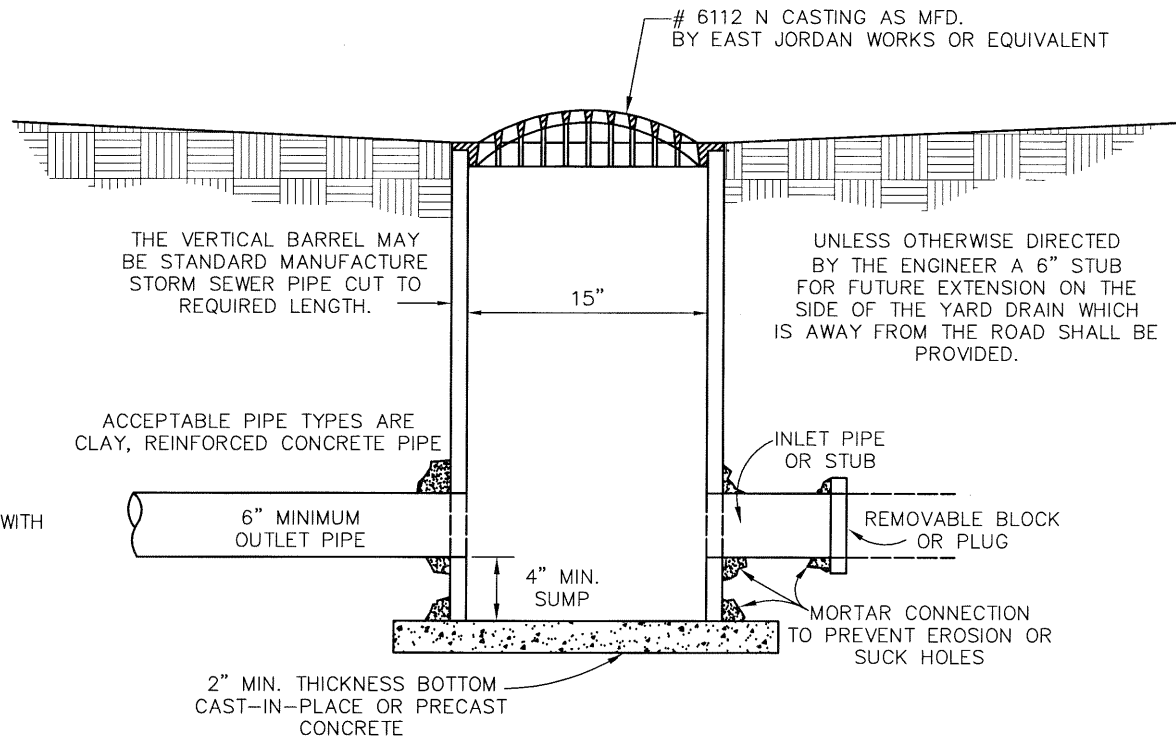

TYPE 3 YARD DRAIN

CITY OF PIQUA

CHOICE ONE ENGINEERING

YARD DRAIN

REVISIONS:

DATE APPROVED:
AUG. 2008

PAGE No.

600-3

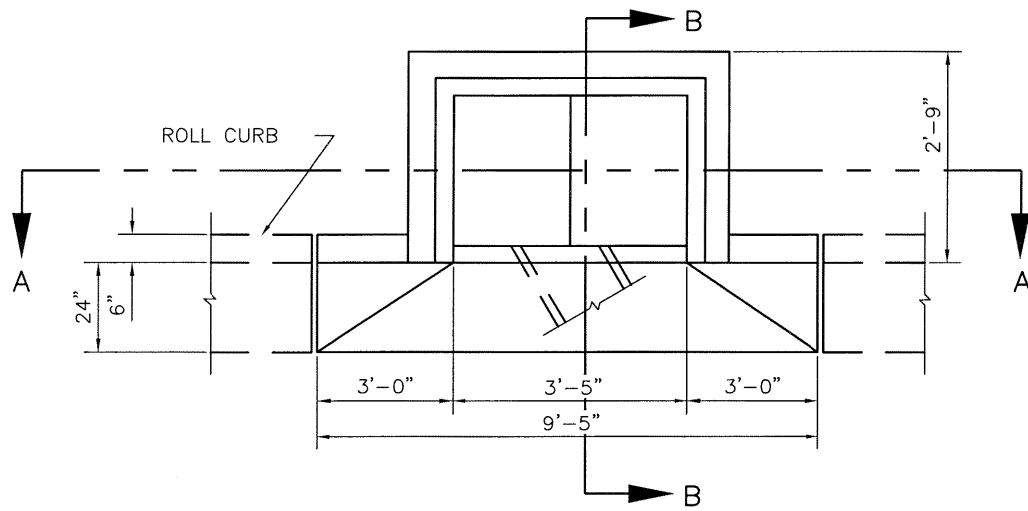

PLAN
(WITH FRAME AND LID REMOVED)

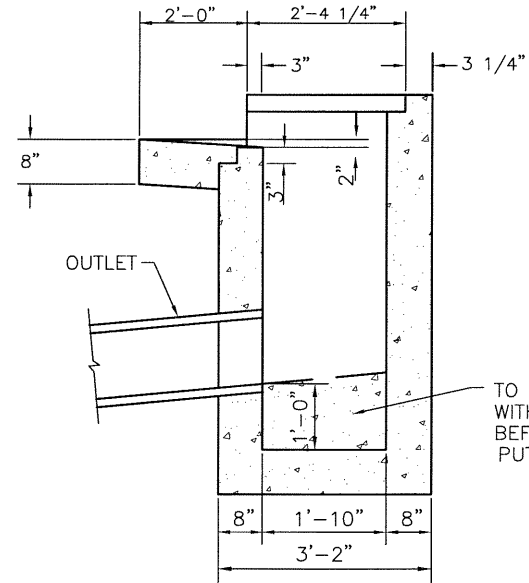

SECTION B-B

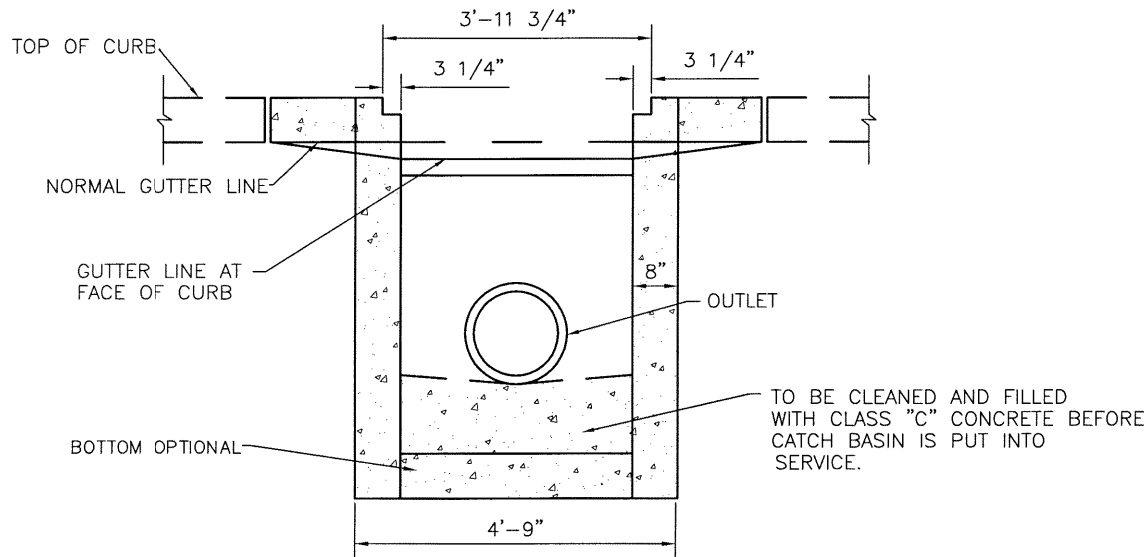

SECTION A-A

NOTES:

- A.** CURBS ALONG APRON TO HAVE VERTICAL FACE AND BE MONOLITHIC WITH APRON.
- B.** FRAME AND LID SHALL BE NEENAH CATALOG No. R-3312-A OR EQUIVALENT.
- C.** CATCH BASIN MAY BE PRECAST UNIT OR POURED IN PLACE.
- D.** PRECAST UNITS SHALL HAVE MINIMUM WALL THICKNESS OF 5 INCH.
- E.** PRECAST UNITS SHALL BE DURA-CRETE CB-915-A OR AN APPROVED EQUAL.
- F.** ALL CATCH BASINS SHALL BE PLACED ON A 6 INCH APPROVED AGGREGATE BASE WITH PRECAST BOTTOM.
- G.** BOTTOM TO BE CONTOURED TO PROVIDE POSITIVE DRAINAGE. THE SLOPE TO BE DETERMINED BY THE ENGINEER.
- H.** THE FRONT EDGE OF CATCH BASIN LID FRAME TO BE FLUSH WITH THE EDGE OF ROLL CURB AND FLUSH WITH FACE OF BARRIER CURB.

CITY OF
PIQUA

CHOICE
ONE
ENGINEERING

TYPE A CATCH BASIN "IN KIND"
FOR REPAIR/MAINTENANCE ONLY AS DIRECTED BY CITY

REVISIONS:

DATE
APPROVED:
AUG. 2008

PAGE No.

600-4

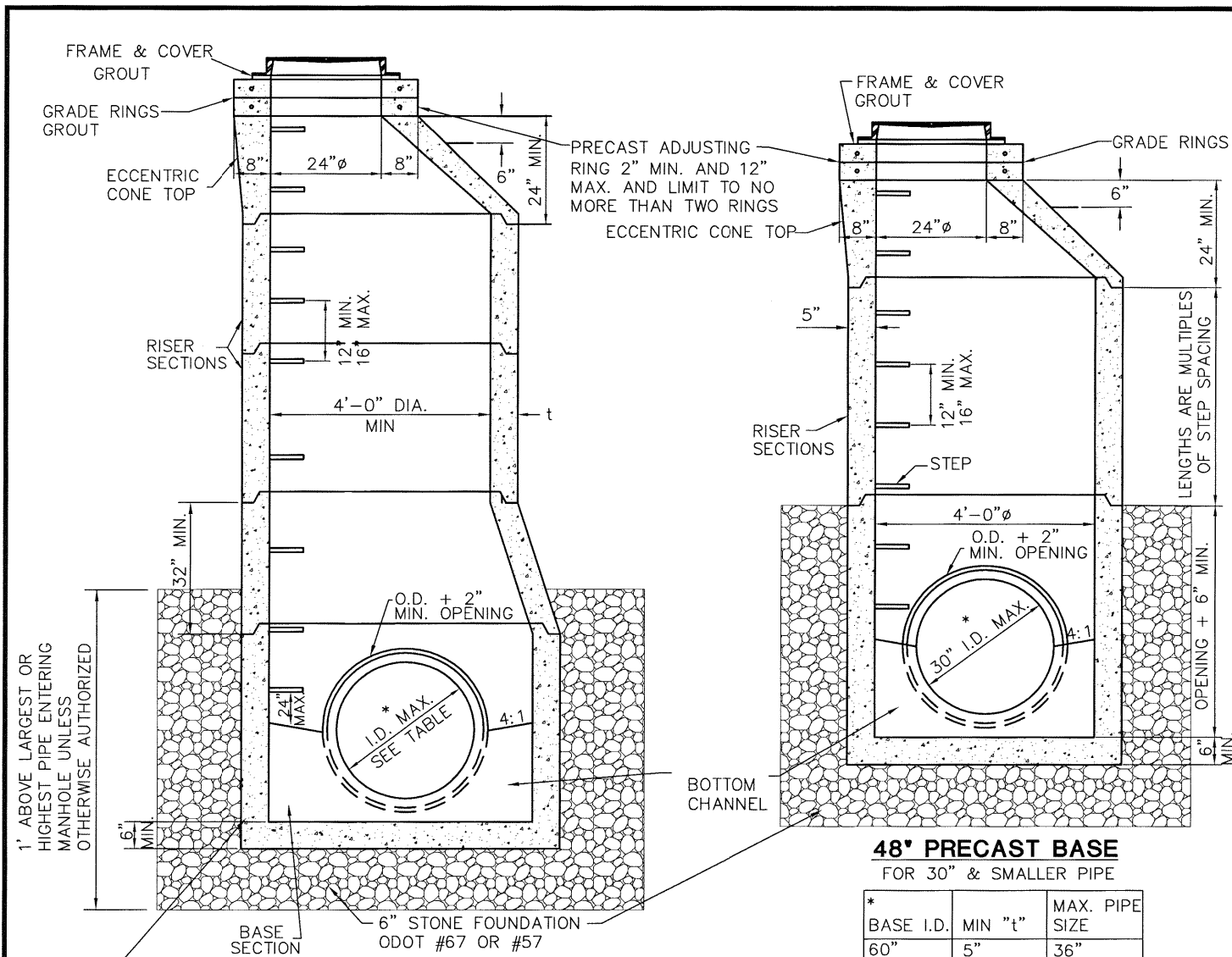

1' ABOVE LARGEST OR HIGHEST PIPE ENTERING MANHOLE UNLESS OTHERWISE AUTHORIZED

60" TO 96" PRECAST BASE
SEE TABLE FOR MAXIMUM PIPE SIZES

48" PRECAST BASE
FOR 30" & SMALLER PIPE

* BASE I.D.	MIN "t"	MAX. PIPE SIZE
60"	5"	36"
72"	6"	48"
84"	7"	54"
90"	7 1/2"	60"
96"	8"	60"

*DUE TO PIPE ORIENTATION, LARGER DIAMETER BASE THAN WHAT IS SPECIFIED TO ACCEPT PIPE MAY BE REQUIRED.

NOTES

- A. STORM MANHOLE FRAME AND APPROVED VENTED LID SHALL BE EQUAL OF NEENAH NO. R-1767 OR EAST JORDON IRON WORKS NO. 1600.
- B. TOP AND TRANSITION (OR REDUCER) SECTIONS MAY BE EITHER ECCENTRIC CONE OR FLAT SLAB.
- C. OPENINGS IN RISER SECTIONS FOR 18 INCH AND SMALLER INLET PIPES MAY BE PREFABRICATED OR CUT IN THE FIELD PROVIDED THE SIDES OF THE PIPE AT THE SPRING LINE DO NOT PROJECT INTO THE MANHOLE.
- D. MATERIALS FOR BASES AND OTHER PRECAST SECTIONS, INCLUDING REINFORCEMENT SHALL COMPLY WITH ODOT REQUIREMENT OF 706.13 (ASTM C-478).
- E. LOCATE THE CENTERLINE OF MANHOLE CONES OVER THE CENTERLINE OF THE MAIN SEWER WHENEVER POSSIBLE.
- F. FOR PIPE SIZES LARGER THAN 60 INCH REFER TO ODOT TYPE 4 TO 5 MANHOLE.
- G. NO LATERALS MAY PROTRUDE INTO THE INTERNAL MANHOLE.
- H. MAXIMUM SPACING SHALL BE 400 FEET.
- I. WHEN CONNECTING TO AN EXISTING STORM MANHOLE CARE SHALL BE TAKEN TO KEEP OPENING AS MINIMAL AS POSSIBLE. IF POSSIBLE, SAW CUT OR USE ROTARY HAMMER FOR OPENING TO MINIMIZE DAMAGE TO STORM MANHOLE AND PIPE MUST BE CUT PARALLEL TO STORM MANHOLE. USE NONSHRINK GROUT AROUND PIPE TO SEAL BETWEEN PIPE AND STORM MANHOLE.
- J. JOINTS BETWEEN SECTIONS TO BE EITHER MORTAR OR BITUMINOUS PIPE JOINT FILLER (ODOT 706.10)

TYPE 3 STORM MANHOLE

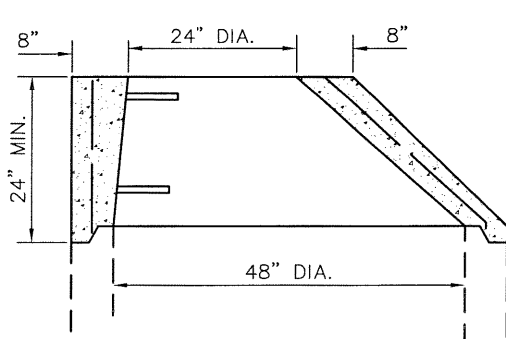

ECCENTRIC CONE TOP

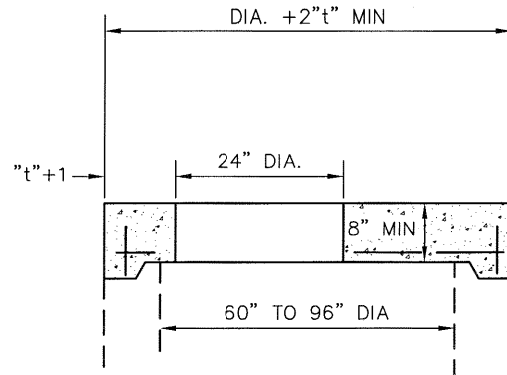

FLAT SLAB TOP

BASE I.D.	MIN "t"	MAX. PIPE SIZE
60"	5"	36"
72"	6"	48"
84"	7"	54"
90"	7 1/2"	60"
96"	8"	60"

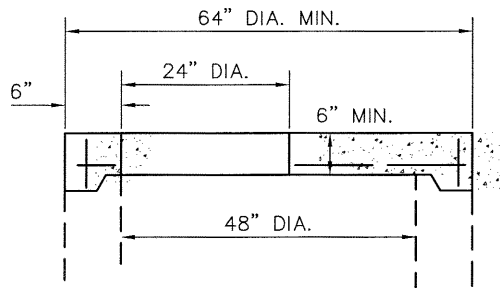

FLAT SLAB TOP

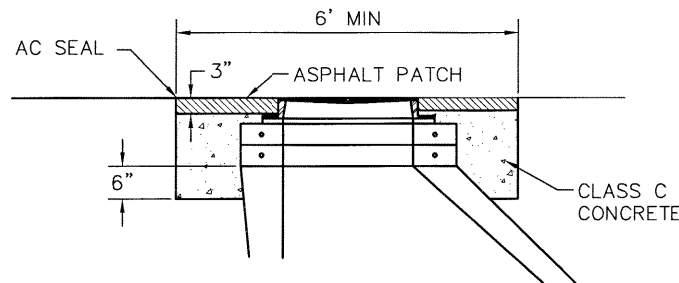

MANHOLE REPAIR CASTING CONSTRUCTION

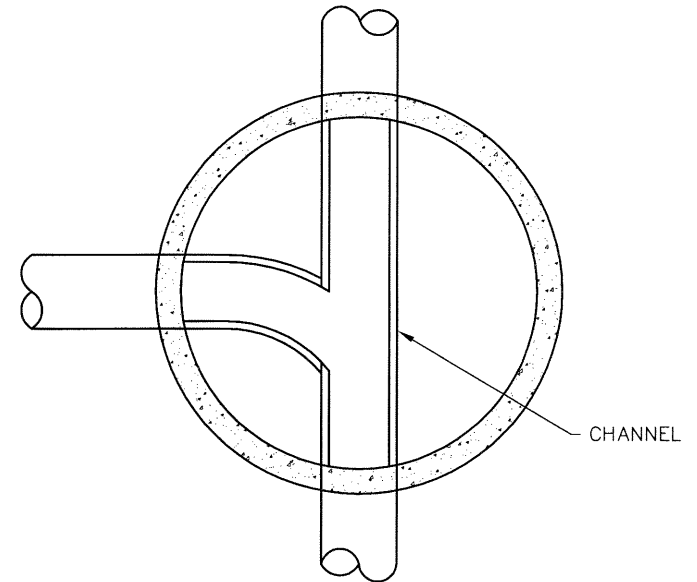

SECTIONAL PLAN

NOTES:

1. PRECAST CONCRETE ADJUSTING RINGS – ENCASE WITH CONCRETE 6 INCHES DOWN FROM BARREL TOP AND UP TO WITHIN 3 INCHES OF SURFACE AND EXTENSIONS.
2. SET MANHOLE, PRECAST CONCRETE ADJUSTING RINGS AND CASTING THEN PAVE OVER MANHOLE. THEN DIG OUT, ENCASE COLLARS AND CASTING AS PER DETAIL WITH CONCRETE TO WITHIN 3 INCHES OF SURFACE. THE MANHOLE WILL HAVE A PATCHED RADIUS OF (3 INCH) ASPHALT.

NOTE

ALL INVERTS TO BE CHANNLED FOR OPTIMUM FLOW.

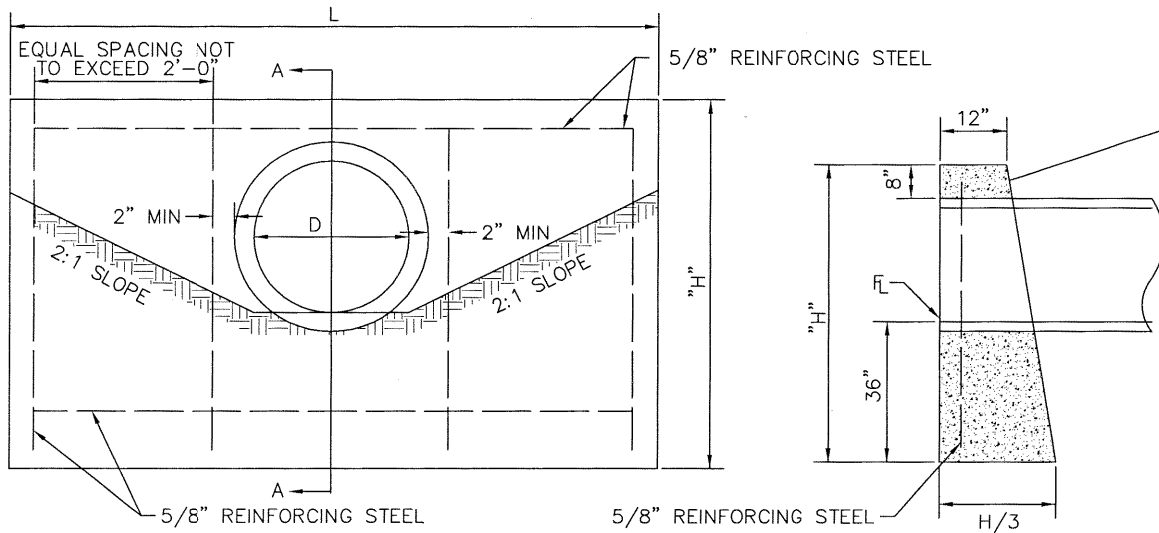

ELEVATION

SECTION A-A

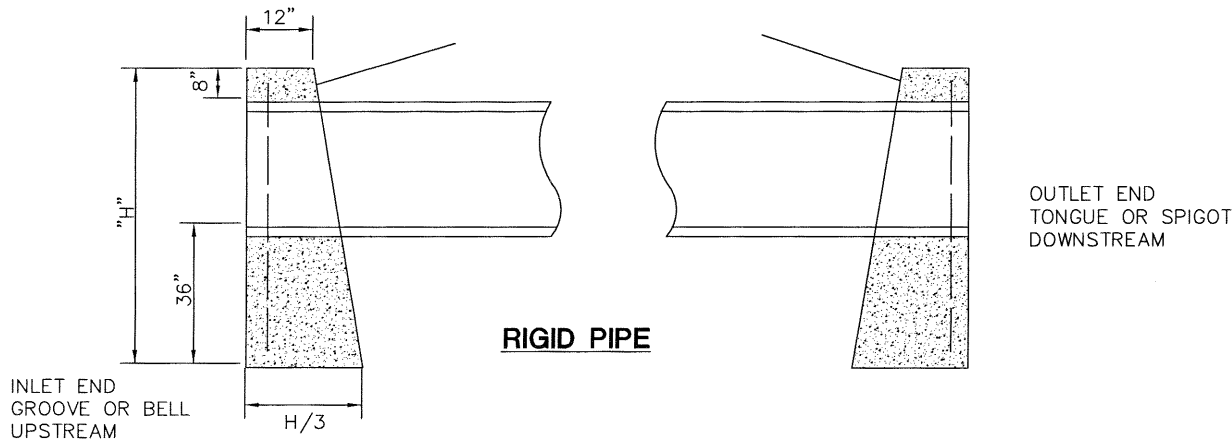

RIGID PIPE

OUTLET END
TONGUE OR SPIGOT
DOWNSTREAM

NOTES

- A. THESE FULL HEIGHT HEADWALLS ARE FOR NONSKEWED CULVERTS HAVING A DIAMETER OR RISE OF 36 INCHES OR LESS.
- B. CONCRETE SHALL BE ODOT CLASS C. REINFORCED STEEL BAR SHALL BE 5/8 INCH ROUND.
- C. DIMENSIONS AND QUANTITIES ARE SHOWN FOR CIRCULAR SECTIONS ONLY. IT WILL BE NECESSARY TO DETERMINE DIMENSIONS FOR THE HW-1 HEADWALL REQUIRED FOR REINFORCED ELLIPTICAL CONCRETE PIPE OR CORRUGATED METAL PIPE ARCHES IN ACCORDANCE WITH THE EQUATIONS LISTED ON THIS DRAWING.
- D. CHAMFER ALL EXPOSED CORNERS 3/4 INCH.
- E. WHERE THE SOIL BORINGS INDICATE A BEARING CAPACITY OF LESS THAN 2600 LBS. PER SQUARE FOOT, IT WILL BE NECESSARY TO INCREASE THE WIDTH OF THE BASE.
- F. MINIMUM COVER FOR REINFORCING STEEL SHALL BE 2 INCH.
- G. FOR PIPES HAVING A DIAMETER OR RISE OVER 36 INCHES, REFERENCE ODOT HW-3 HEADWALLS FOR FULL HEIGHT HEADWALL.
- H. FOR SKEWED CULVERTS HAVING A DIAMETER OR RISE OF 36 INCHES OR LESS, REFERENCE ODOT HW-2 HEADWALLS.
- I. HEADWALLS MAY BE PRECAST CONCRETE CONSTRUCTED TO THE ABOVE REQUIREMENTS. GROUT AROUND PIPE AFTER INSTALLATION.

DIMENSIONS			QUANTITIES ONE HEADWALL	
DIAMETER	HEIGHT	LENGTH	CONCRETE C.Y.	REINFORCING STEEL LBS.
15"	5'-2"	7'-0"	1.7	41
18"	5'-5"	8'-4"	2.2	57
21"	5'-8"	9'-8"	2.8	62
24"	5'-11"	11'-0"	3.3	69
30"	6'-5"	13'-8"	4.7	92
36"	7'-0"	16'-4"	6.5	105

L CIRCULAR SECTIONS = $5D + 4T$
 L ELLIPTICAL OR PIPE-ARCH = $4R + 4T + S$
 H CIRCULAR SECTIONS = $D + T + 44"$
 H ELLIPTICAL OR PIPE-ARCH = $R + T + 44"$
 D = DIAMETER OF PIPE R = RISE OF PIPE
 S = SPAN OF PIPE T = THICKNESS OF BARREL
 L = LENGTH OF HEADWALL H = HEIGHT OF HEADWALL

CITY OF
PIQUA

CHOICE
ONE
ENGINEERING

FULL-HEIGHT HEADWALL

REVISIONS:

DATE
APPROVED:
AUG. 2008

PAGE No.

600-7

NOTES

- A. CONCRETE FOR HEADWALLS SHALL BE ODOT CLASS C. CONCRETE QUANTITIES ARE BASED ON HEADWALLS ONLY.
- B. HEADWALLS MAY BE PRECAST CONCRETE CONSTRUCTED TO THE ABOVE REQUIREMENTS. GROUT AROUND PIPE AFTER INSTALLATION.
- C. LAST 20 FEET ± OF PIPE BEFORE HEADWALL SHALL BE REINFORCED CONCRETE PIPE.
- D. A CONCRETE SLAB IS REQUIRED FOR PIPES WITH A DIAMETER OF 18 INCH AND ABOVE.

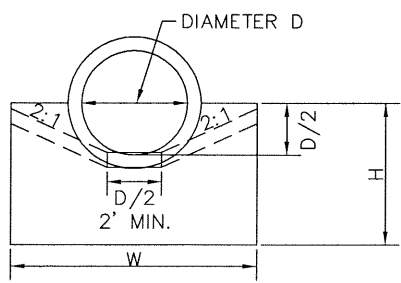

CIRCULAR

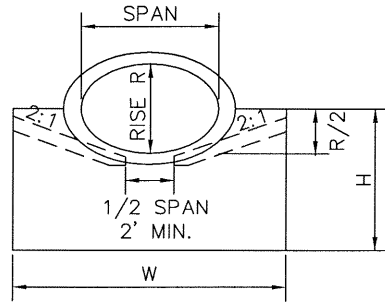

ELLIPTICAL

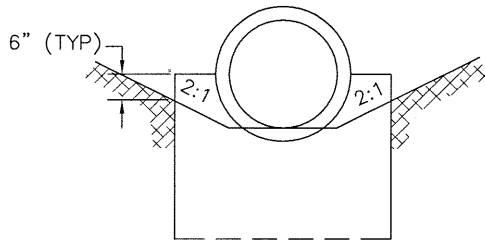

WIDTH OF PROTECTION SHALL EQUAL WIDTH OF HEADWALL. MINIMUM WIDTH 4'-0"

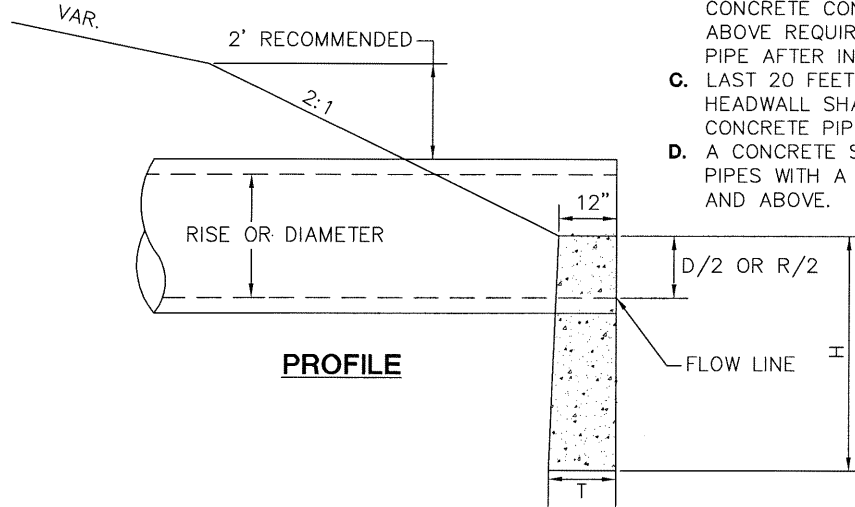

PROFILE

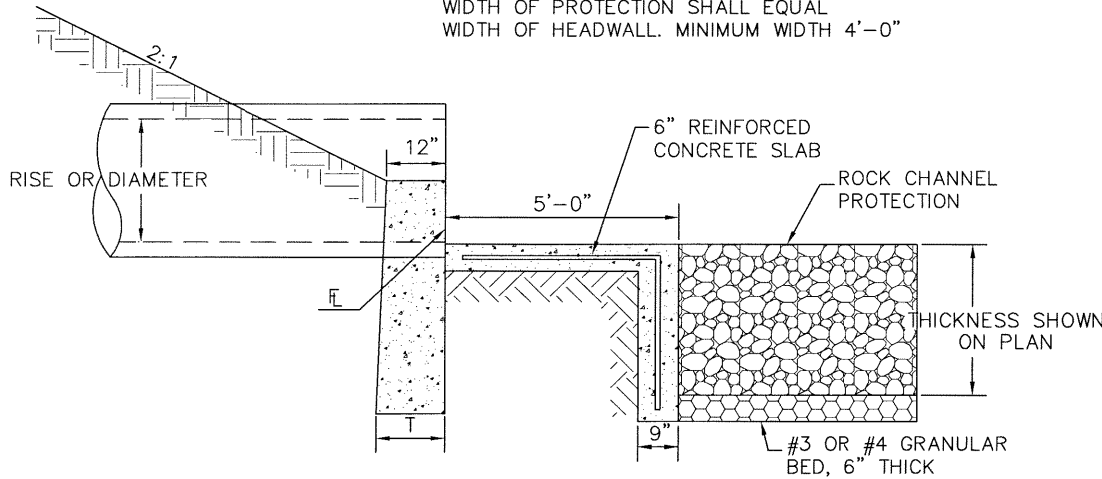

OUTLET CHANNEL PROTECTION DETAIL

(CUTOFF WALL DEPTH 2'-6" MINIMUM IS VARIABLE TO MATCH REQUIRED THICKNESS OF ROCK.)

HEADWALL FOR CONCRETE PIPE

CIRCULAR				CONC. C.Y.	ELLIPTICAL					CONC. C.Y.
D	W	H	T		SPAN	RISE	W	H	T	
12"	2'-0"	3'-0"	12"	.20	23"	14"	3'-0"	3'-2"	12"	.29
15"	2'-6"	3'-2"	12"	.25	30"	19"	3'-7"	3'-4"	12"	.35
18"	3'-0"	3'-3"	12"	.31	34"	22"	3'-11"	3'-5"	12"	.38
21"	3'-6"	3'-4"	12"	.37	38"	24"	4'-6"	3'-6"	12"	.44
24"	4'-0"	3'-6"	12"	.43	42"	27"	4'-8"	3'-7"	12"	.45
27"	4'-6"	3'-8"	12"	.49	45"	29"	5'-2"	3'-8"	12"	.49
30"	5'-0"	3'-9"	12"	.56	49"	32"	5'-5"	3'-10"	12"	.52
33"	5'-6"	3'-10"	12"	.62	53"	34"	5'-11"	4'-0"	14"	.66
36"	6'-0"	4'-0"	12"	.69	60"	38"	6'-10"	4'-2"	14"	.82
39"	6'-6"	4'-2"	12"	.77	68"	43"	8'-0"	4'-4"	16"	1.01
42"	7'-0"	4'-3"	12"	.84	76"	48"	9'-2"	5'-0"	16"	1.34
48"	8'-0"	4'-6"	14"	1.09	83"	53"	10'-4"	5'-2"	18"	1.65
54"	9'-3"	4'-9"	14"	1.32	91"	58"	11'-6"	5'-5"	18"	1.97
60"	10'-6"	5'-6"	16"	1.93	98"	63"	12'-7"	5'-7"	20"	2.38
66"	11'-9"	5'-9"	18"	2.42	106"	68"	13'-9"	5'-10"	20"	2.69
72"	13'-0"	6'-0"	18"	2.77	113"	72"	14'-9"	6'-0"	22"	3.14
78"	14'-3"	6'-3"	20"	3.37	121"	77"	15'-11"	6'-3"	22"	3.49
84"	15'-6"	6'-6"	22"	4.05	128"	82"	17'-0"	6'-5"	24"	4.04

CITY OF PIQUA

CHOICE ONE ENGINEERING

HALF-HEIGHT HEADWALL

REVISIONS:

DATE APPROVED: AUG. 2008

PAGE No.

600-8

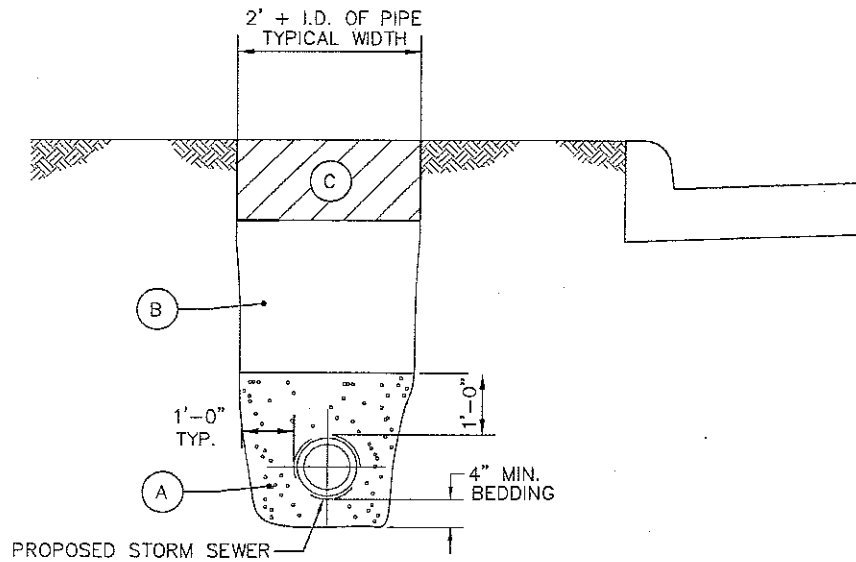

STORM SEWER TRENCH DETAIL
(NON-RIGID PIPE)

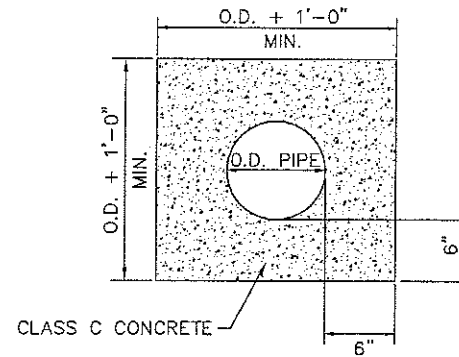

CONCRETE ENCASEMENT DETAIL

TRENCH DETAIL NOTES

A. GRANULAR BEDDING SHALL BE CRUSHED STONE OR GRAVEL, ODOT 603 TYPE 3 (#57 OR #67), OR OTHER APPROVED EQUIVALENT.

B. ALL TRENCHES OUTSIDE THE RIGHT-OF-WAY FROM PROPOSED OR EXISTING PAVEMENT, CURB, DRIVEWAYS, ALLEYS, STONE AREAS OR WALKS CAN BE COMPACTED WITH EXISTING NATIVE MATERIAL IN 12 INCH MAXIMUM LIFTS OR AS APPROVED BY THE CITY. NO MATERIAL SHALL BE USED FOR BACK FILLING THAT CONTAINS STONE, ROCKS, ETC., GREATER THAN 4 INCH DIAMETER.

ALL TRENCHES INSIDE THE RIGHT-OF-WAY FROM PROPOSED OR EXISTING PAVEMENT, CURB, DRIVEWAYS, ALLEYS, STONE AREAS OR WALKS SHALL BE COMPACTED WITH GRANULAR BACKFILL MATERIAL ODOT 603 TYPE 1 IN 6 INCH MAXIMUM LIFTS.

A DENSITY TEST ON GRANULAR BACKFILL OF 98% OF ASTM D698 STANDARD PROCTOR CURVE MAY BE REQUIRED TO BE PERFORMED BY A COMMERCIAL TESTING LAB SATISFACTORY TO THE CITY.

C. OFF-PAVEMENT AREAS SHALL BE PROVIDED WITH A MINIMUM OF 6 INCH OF TOPSOIL OVER THE COMPACTED MATERIAL AND THEN SEEDED AND MULCHED PER ODOT ITEM 659.

IN-PAVEMENT AREAS SHALL FOLLOW TYPICAL PAVEMENT RESTORATION DETAILS SHOWN ON PAGE 300-19.

D. THE OPEN ENDS OF ALL PIPES SHALL BE PLUGGED TO THE APPROVAL OF THE CITY BEFORE LEAVING THE WORK FOR THE NIGHT.

CITY OF
PIQUA

ENGINEERING
ONE

STORM SEWER TRENCH DETAILS

REVISIONS:
02/24/10

DATE
APPROVED:
AUG. 2008
PAGE No.
600-9

NOTES

- A. NO WORK SHALL BE APPROVED OR ACCEPTED BY THE CITY UNLESS 2 WORKING DAYS NOTICE OF COMMENCING WORK IS GIVEN TO THE CITY.
- B. ALL TEMPORARY PAVEMENT AND SIDEWALK SHALL BE MAINTAINED BY THE CONTRACTOR OR THE DEVELOPER AT HIS OWN EXPENSE IN A SUITABLE AND SAFE CONDITION FOR TRAFFIC UNTIL PERMANENT REPLACEMENT IS MADE OR THE PROJECT IS FINALLY ACCEPTED BY THE CITY.
- C. ALL STORM SEWER CONSTRUCTION SHALL ADHERE TO ODOT SPECIFICATIONS LATEST REVISION OR WITH THE CITY STORM SEWER SPECIFICATIONS, WHICHEVER IS APPLICABLE AND MORE RESTRICTIVE.
- D. MASTIC MATERIAL IS REQUIRED ON ALL NON O-RING STORM SEWER AND MANHOLES, UNLESS OTHERWISE APPROVED.
- E. WHEN A CASTING IS REMOVED IT REMAINS CITY PROPERTY AND TO BE DELIVERED TO THE CITY SERVICE CENTER, UNLESS OTHERWISE APPROVED.
- F. ANY DETAILS OR NOTES NOT DIRECTLY ADDRESSED IN THESE ENGINEERING STANDARDS SHALL BE COORDINATED WITH THE CITY ENGINEERING DEPARTMENT.
- G. ALL STORM SEWER SHALL BE INSTALLED USING A PIPE LASER, INSIDE THE PIPE IF POSSIBLE, FOR GRADE AND ALIGNMENT.

UTILITY STAKING

- A. OFFSET AND GRADE AT EACH MANHOLE, CATCH BASIN, AND OTHER STRUCTURES. OFFSET AND GRADE 50 FEET AND 100 FEET OUT FROM EACH MANHOLE UNLESS OTHERWISE APPROVED.

PIPE

- A. ALL STORM SEWER PIPE SHALL HAVE A MINIMUM DIAMETER OF 12 INCH, UNLESS OTHERWISE APPROVED.
- B. TYPES OF PIPE PERMITTED

OUTSIDE THE RIGHT-OF-WAY

REINFORCED CONCRETE PIPE
 REINFORCED CONCRETE ELLIPTICAL PIPE
 CORRUGATED POLYETHYLENE SMOOTH-LINED PIPE
 POLYVINYL CHLORIDE PLASTIC PIPE
 (NON-PERFORATED)
 POLYVINYL CHLORIDE CORRUGATED
 SMOOTH-INTERIOR PIPE
 POLYVINYL CHLORIDE PROFILE WALL PIPE
 POLYVINYL CHLORIDE SOLID WALL PIPE

ODOT MATERIALS NUMBER

706.02
 706.04
 707.33
 707.41
 707.42
 707.43
 707.45

WITHIN THE RIGHT-OF-WAY

REINFORCED CONCRETE PIPE *
 REINFORCED CONCRETE ELLIPTICAL PIPE *

ODOT MATERIALS NUMBER

706.02
 706.04

* MINIMUM OF CLASS IV – WALL B

EXISTING TILE HOOKUPS

- A. THE DRAINAGE TILE CURRENTLY CONNECTED TO THE EXISTING STORM SEWER SHALL BE CONNECTED TO THE PROPOSED STORM SEWER. ANY DRAINAGE TILE DAMAGED BY THE CONTRACTOR SHALL BE REPLACED BY THE CONTRACTOR TO A CONDITION EQUAL TO OR BETTER THAN ITS ORIGINAL CONDITION. ANYTHING REMOVED, REPLACED, AND/OR CONNECTED TO THE STORM SEWER SHALL BE NOTED ON THE AS-BUILT DRAWINGS AND SHALL BE INSPECTED BY THE INSPECTOR BEFORE THEY ARE COVERED.
- B. ALL FIELD OR STORM DRAINS WHICH ARE ENCOUNTERED DURING CONSTRUCTION SHALL BE PROVIDED WITH UNOBSTRUCTED OUTLETS OR PLUGGED AS APPROVED AND DIRECTED BY THE CITY.

CITY OF
PIQUA

CHOICE
ONE
ENGINEERING

MISCELLANEOUS STORM NOTES

REVISIONS:

DATE
APPROVED:
AUG. 2008

PAGE No.
600-10

NOTES

A. TEMPORARY EROSION AND SEDIMENT CONTROL MEASURES SHALL BE PROVIDED FOR ALL CONSTRUCTION PROJECTS HAVING SIGNIFICANT GRADING. THE CONTROLS ARE PROVIDED DURING CONSTRUCTION TO PREVENT SOIL ERODED FROM THE CONSTRUCTION AREA FROM ENTERING ADJACENT WATERWAYS AND PROPERTIES.

B. CONSTRUCTION ITEMS INCLUDE SEDIMENT BASINS, SEDIMENT DAMS, DIVERSION DIKES AND/OR DITCHES AND STRAW BALES OR OTHER FILTER DIKES SHOWN ON ODOT STANDARD DRAWING MC-11. OTHER MISCELLANEOUS EROSION CONTROL MEASURES INCLUDE REPAIR SEEDING AND MULCHING, COMMERCIAL FERTILIZER, WATER AND MOWING AND ROCK CHANNEL PROTECTION, COVERED IN ODOT SPECIFICATION ITEMS 659 AND 601.

C. THE SIZE OF THE ENTIRE DRAINAGE AREA CONTRIBUTING FLOW IS USED TO DETERMINE THE MOST EFFECTIVE EROSION CONTROL METHOD. IN MANY CASES, THE MAJOR PORTION OF THE CONTRIBUTING AREA WILL BE BEYOND THE PROJECT LIMITS, AND FOR THOSE CASES IT WILL BE NECESSARY TO CONTROL THE FLOW FROM OUTSIDE BEFORE IT REACHES THE AREA DISTURBED BY PROJECT CONSTRUCTION. FLOW FROM THE AREA DISTURBED BY CONSTRUCTION SHALL BE TREATED PRIOR TO COMBINING IT WITH OFF-PAVEMENT DRAINAGE.

D. EROSION AND SEDIMENT CONTROL MEASURES SHALL BE PROVIDED FOR ALL SUBDIVISIONS AND INDIVIDUAL SITES UNLESS OTHERWISE APPROVED. THE CONTROL MEASURES ARE TO BE PROVIDED DURING CONSTRUCTION TO PREVENT EROSION FROM ENTERING ADJACENT WATERWAYS AND PROPERTIES.

E. THERE SHALL BE ONLY ONE CONSTRUCTION ENTRANCE OFF THE SITE, ENTRANCE TO BE CONSTRUCTED OF 8" OF #2 STONE, 75 FEET LONG BY 20 FEET WIDE. CONTRACTOR TO KEEP MUD OFF EXISTING STREETS, NO EQUIPMENT TO BE PARKED ON EXISTING STREETS. MORE THAN ONE ENTRANCE MUST BE APPROVED BY THE CITY.

PLAN SUBMITTAL

A. ALL SITE PLANS SHALL INCLUDE APPROPRIATE EROSION AND SEDIMENT CONTROL DEVICES AND SHALL BE SUBMITTED TO THE CITY FOR APPROVAL PRIOR TO COMMENCEMENT OF ANY WORK UNLESS OTHERWISE APPROVED. ALL PROJECTS WHICH DISTURB 1 ACRES OR MORE MUST HAVE OEPA EROSION CONTROL APPROVALS.

CONSTRUCTION

A. ALL EROSION AND SEDIMENT CONTROL DEVICES MUST BE INSPECTED AND APPROVED BY THE CITY UNLESS OTHERWISE APPROVED.

STORM WATER PERMITS

A. ON ALL PROJECTS WHICH DISTURB AT LEAST 1 ACRE OF SOIL, A NPDES PERMIT IS REQUIRED FROM OEPA AND A COPY OF THE PERMIT MUST BE ON FILE AT THE CITY BEFORE CONSTRUCTION BEGINS.

B. EROSION CONTROL SUBMITTALS SHALL BE AS PER THE CURRENT STORM WATER MANAGEMENT ORDINANCE.

CONTROL MEASURES

A. DISTURB ONLY THE AREAS NEEDED FOR CONSTRUCTION.

B. REMOVE ONLY THOSE TREES, SHRUBS, AND GRASSES THAT MUST BE REMOVED FOR CONSTRUCTION; PROTECT THE REST TO PRESERVE THEIR ESTHETIC AND EROSION-CONTROL VALUES.

C. INSTALL SEDIMENT BASINS AND DIVERSION DIKES BEFORE DISTURBING THE LAND THAT DRAINS INTO THEM.

D. INSTALL EROSION AND SEDIMENT CONTROL PRACTICES AS INDICATED IN THE PLAN. THE PRACTICES ARE TO BE MAINTAINED IN EFFECTIVE WORKING CONDITION DURING CONSTRUCTION AND UNTIL THE DRAINAGE AREAS HAVE BEEN PERMANENTLY STABILIZED.

E. TEMPORARILY STABILIZE EACH SEGMENT, GRADED OR OTHERWISE DISTURBED LAND, INCLUDING THE SEDIMENT-CONTROL DEVICES NOT OTHERWISE STABILIZED, BY SEEDING AND MULCHING OR BY MULCHING ALONE. AS CONSTRUCTION IS COMPLETED, PERMANENTLY STABILIZE EACH SEGMENT WITH PERENNIAL VEGETATION AND STRUCTURAL MEASURES.

F. LEVEL DIVERSION DIKES, SEDIMENT BASINS, AND SILT TRAPS AFTER AREAS THAT DRAIN INTO THEM ARE STABILIZED. ESTABLISH PERMANENT VEGETATION ON THESE AREAS. SEDIMENT BASINS THAT ARE TO BE RETAINED FOR STORM WATER DETENTION MAY BE SEEDED TO PERMANENT VEGETATION AFTER THEY ARE BUILT.

G. DISCHARGE WATER FROM OUTLET STRUCTURES AT NON-EROSIVE VELOCITIES.

CITY OF PIQUA

CHOICE ONE ENGINEERING

EROSION CONTROL NOTES

REVISIONS:	DATE APPROVED: AUG. 2008
	PAGE No. 600-11

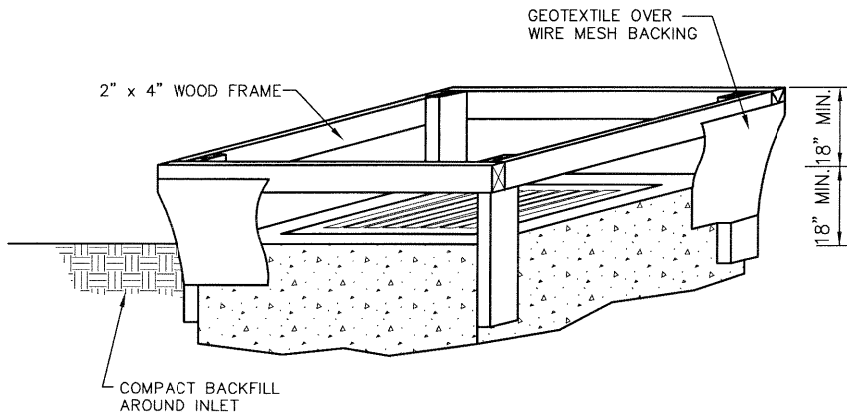

INLET PROTECTION IN SWALES, DITCH LINES OR YARD INLETS

- A. INLET PROTECTION SHALL BE CONSTRUCTED EITHER BEFORE UPSLOPE LAND DISTURBANCE BEGINS OR BEFORE THE STORM DRAIN BECOMES OPERATIONAL.
- B. THE EARTH AROUND THE INLET SHALL BE EXCAVATED COMPLETELY TO A DEPTH A LEAST 18 INCHES..
- C. THE WOODEN FRAME SHALL BE CONSTRUCTED OF 2 INCH BY 4 INCH CONSTRUCTION GRADE LUMBER. THE 2 FOOT BY 4 FOOT POST SHALL BE DRIVEN 1 FOOT INTO THE GROUND AT FOUR CORNERS OF THE INLET AND AND THE TOP PORTION OF 2 INCH BY 4 INCH FRAME ASSEMBLED USING THE OVERLAP JOINT SHOWN. THE TOP OF THE FRAME SHALL BE AT LEAST 6 INCHES BELOW ADJACENT ROAD, IF PONDED WATER WOULD POSE A SAFETY HAZARD TO TRAFFIC.
- D. WIRE MESH SHALL BE OF SUFFICIENT STRENGTH TO SUPPORT FABRIC WITH WATER FULLY IMPOUNDED AGAINST IT. IT SHALL BE STRETCHED TIGHTLY AROUND THE FRAME AND FASTENED SECURELY TO THE FRAME.
- E. GEOTEXTILE SHALL HAVE AN EQUIVALENT OPENING SIZE OF 20-40 SIEVE AND BE RESISTANT TO SUNLIGHT. IT SHALL BE STRETCHED TIGHTLY AROUND THE FRAME AND FASTENED SECURELY. IT SHALL EXTEND FROM THE TOP OF THE FRAME TO 18 INCHES BELOW THE INLET NOTCH ELEVATION. THE GEOTEXTILE SHALL OVERLAY ACROSS ONE SIDE OF THE INLET SO THE ENDS OF THE CLOTH ARE NOT FASTENED TO THE SAME POST.
- F. BACKFILL SHALL BE PLACED AROUND THE INLET IN COMPACTED 6 INCH LAYERS UNTIL THE EARTH IS EVEN WITH NOTCH ELEVATION ON ENDS AND TOP ELEVATION ON SIDES.
- G. A COMPACTED EARTH DIKE OR A CHECK DAM SHALL BE CONSTRUCTED IN THE DITCH LINE BELOW THE INLET IF THE INLET IS NOT IN A DEPRESSION, AND IF RUNOFF BY PASSING THE INLET WILL NOT FLOW TO A SETTING POND, THE TOP OF EARTH DIKES SHALL BE AT LEAST 6 INCHES HIGHER THAN THE TOP OF THE FRAME.

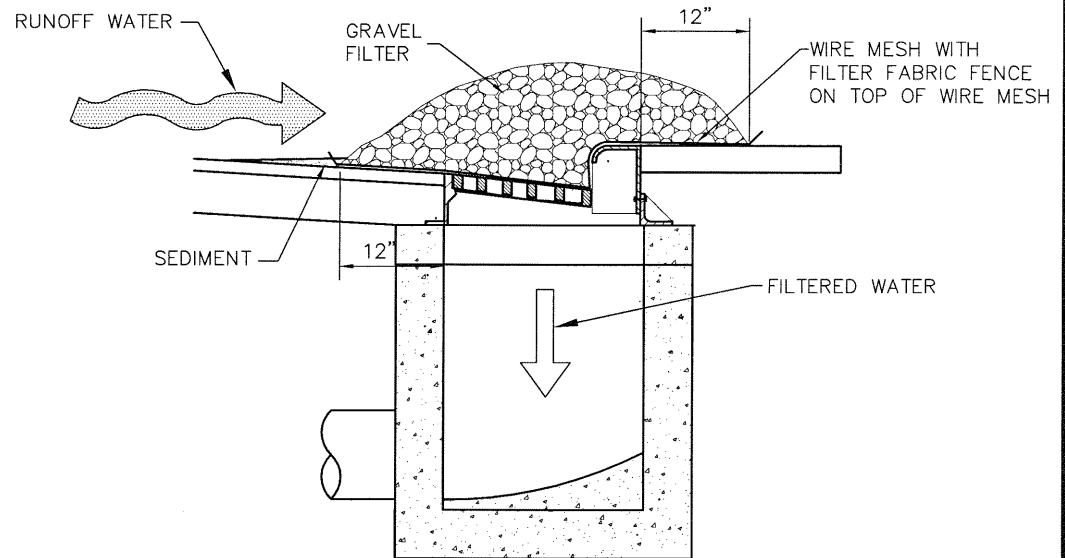

GRAVEL CURB INLET SEDIMENT FILTER (AS REQUIRED BY THE CITY)

GRAVEL CURB INLET SEDIMENT FILTER NOTES

- A. HARDWARE CLOTH OR COMPARABLE WIRE MESH WITH 1/2-INCH OPENINGS SHALL BE PLACED OVER THE CURB INLET OPENING SO THAT AT LEAST 12 INCHES OF WIRE EXTENDS ACROSS THE INLET COVER AND AT LEAST 12 INCHES OF WIRE EXTENDS ACROSS THE CONCRETE GUTTER FROM THE INLET OPENING, AS ILLUSTRATED.
- B. STONE SHALL BE PILED AGAINST THE WIRE SO AS TO ANCHOR IT AGAINST THE GUTTER AND INLET COVER AND TO COVER THE INLET OPENING COMPLETELY. ODOT NO. 1 COARSE AGGREGATE SHALL BE USED.
- C. IF THE STONE FILTER BECOMES CLOGGED WITH SEDIMENT SO THAT IT NO LONGER PERFORMS ITS FUNCTION, THE STONE MUST BE PULLED AWAY FROM THE CATCH BASIN, CLEANED AND REPLACED.

CITY OF
PIQUA

CHOICE
ONE
ENGINEERING

TEMPORARY EROSION CONTROL SAMPLES

REVISIONS:

DATE
APPROVED:
AUG. 2008

PAGE No.

600-12

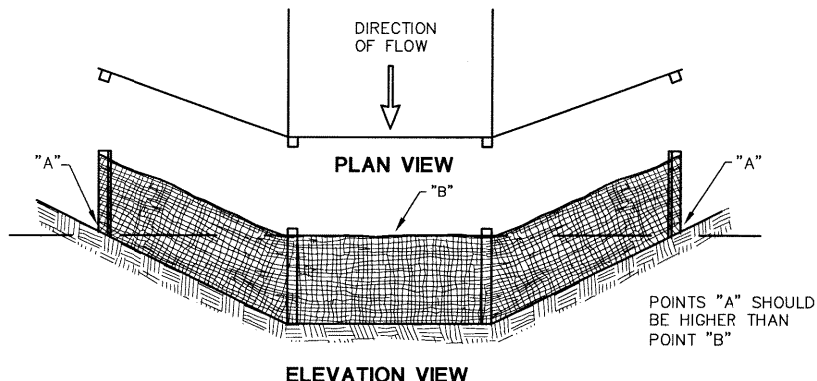

PLACEMENT AND CONSTRUCTION OF DITCH CHECK FILTER FABRIC FENCE

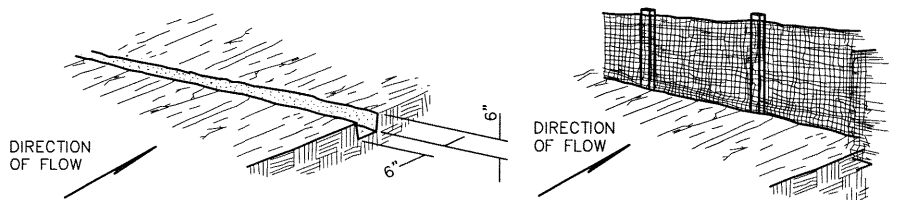

EXCAVATE A 6"x6" TRENCH ALONG THE PROPOSED FENCE LINE.

STEP 1

PLACE FABRIC AND SUPPORT STAKES AND EXTEND FABRIC INTO THE TRENCH.

STEP 2

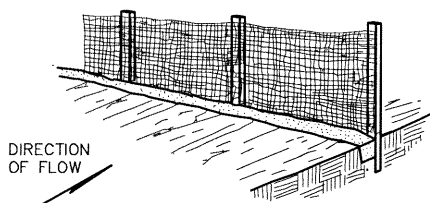

BACKFILL AND COMPACT THE EXCAVATED SOIL.

STEP 3

PLACEMENT AND CONSTRUCTION OF PERIMETER FILTER FABRIC FENCE

CONSTRUCTION OF A FILTER BARRIER (SILT FENCE)

- A. SILT FENCE SHALL BE CONSTRUCTED BEFORE UPSLOPE LAND DISTURBANCE BEGINS.
- B. ALL SILT FENCE SHALL BE PLACED AS CLOSE TO THE CONTOUR AS POSSIBLE SO THAT WATER WILL NOT CONCENTRATE AT LOW POINTS IN THE FENCE AND SO THAT SMALL SWALES OR DEPRESSIONS WHICH MAY CARRY SMALL CONCENTRATED FLOWS TO THE SILT FENCE ARE DISSIPATED ALONG ITS LENGTH.
- C. TO PREVENT WATER PONDED BY THE SILT FENCE FROM FLOWING AROUND THE ENDS, EACH END SHALL BE CONSTRUCTED UPSLOPE SO THAT THE ENDS ARE AT A HIGHER ELEVATION.
- D. WHERE POSSIBLE, SILT FENCE SHALL BE PLACED ON THE FLATTEST AREA AVAILABLE.
- E. WHERE POSSIBLE, VEGETATION SHALL BE PRESERVED FOR 5 FEET (OR AS MUCH AS POSSIBLE) UPSLOPE FROM THE SILT FENCE. IF VEGETATION IS REMOVED, IT SHALL BE REESTABLISHED WITHIN 7 DAYS FROM THE INSTALLATION OF THE SILT FENCE.
- F. THE HEIGHT OF THE SILT FENCE SHALL BE A MINIMUM OF 16 INCHES ABOVE THE ORIGINAL GROUND SURFACE.
- G. THE SILT FENCE SHALL BE PLACED IN A TRENCH CUT A MINIMUM OF 6 INCHES DEEP. THE TRENCH SHALL BE CUT WITH A TRENCHER, CABLE LAYING MACHINE, OR OTHER SUITABLE DEVICE WHICH WILL ENSURE AN ADEQUATELY UNIFORM TRENCH DEPTH.
- H. THE SILT FENCE SHALL BE PLACED WITH THE STAKES ON THE DOWNSLOPE SIDE OF THE GEOTEXTILE AND SO THAT 8 INCHES OF CLOTH IS BELOW THE GROUND SURFACE. EXCESS MATERIAL SHALL LAY ON THE BOTTOM OF THE 6 INCH DEEP TRENCH. THE TRENCH SHALL BE BACKFILLED AND COMPACTED.
- I. SEAMS BETWEEN SECTIONS OF SILT FENCE SHALL BE OVERLAPPED WITH THE END STAKES OF EACH SECTION WRAPPED TOGETHER BEFORE DRIVING INTO THE GROUND.
- J. MAINTENANCE – SILT FENCE SHALL ALLOW RUNOFF TO PASS ONLY AS DIFFUSE FLOW THROUGH THE GEOTEXTILE. ALL THE GAPS AND TEARS IN THE FENCE MUST BE ELIMINATED AND REPAIRED. IF RUNOFF OVERTOPS THE SILT FENCE, FLOWS UNDER OR AROUND THE ENDS, OR IN ANY OTHER WAY BECOMES A CONCENTRATED FLOW, ONE OF THE FOLLOWING SHALL BE PERFORMED, AS APPROPRIATE: 1) THE LAYOUT OF THE SILT FENCE SHALL BE CHANGED, 2) ACCUMULATED SEDIMENT SHALL BE REMOVED, OR 3) OTHER PRACTICES SHALL BE INSTALLED.

CRITERIA FOR SILT FENCE MATERIAL

- A. FENCE POSTS – THE LENGTH SHALL BE A MINIMUM OF 32 INCHES LONG. WOOD POSTS WILL BE 2 FEET-BY-2 FEET HARDWOOD OF SOUND QUALITY. THE MAXIMUM SPACING BETWEEN POSTS SHALL BE 10 FEET.
- B. SILT FENCE FABRIC SHALL BE ODOT TYPE C GEOTEXTILE FABRIC OR AS DESCRIBED BY THE CHART BELOW:

FABRIC PROPERTIES	
MINIMUM TENSILE STRENGTH	120 LBS.
MAXIMUM ELONGATION AT 60 LBS	50%
MINIMUM PUNCTURE STRENGTH	50 LBS.
MINIMUM TEAR STRENGTH	40 LBS.
MINIMUM BURST STRENGTH	200 PSI
APPARENT OPENING SIZE	≤ 0.84mm
MINIMUM PERMITTIVITY	1X10 ⁻² sec. ⁻¹
ULTRAVIOLET EXPOSURE STRENGTH RETENTION	70%

CITY OF PIQUA

CHOICE ONE
ENGINEERING

TEMPORARY EROSION CONTROL SAMPLES

REVISIONS:

DATE APPROVED:
AUG. 2008
PAGE No.

600-13

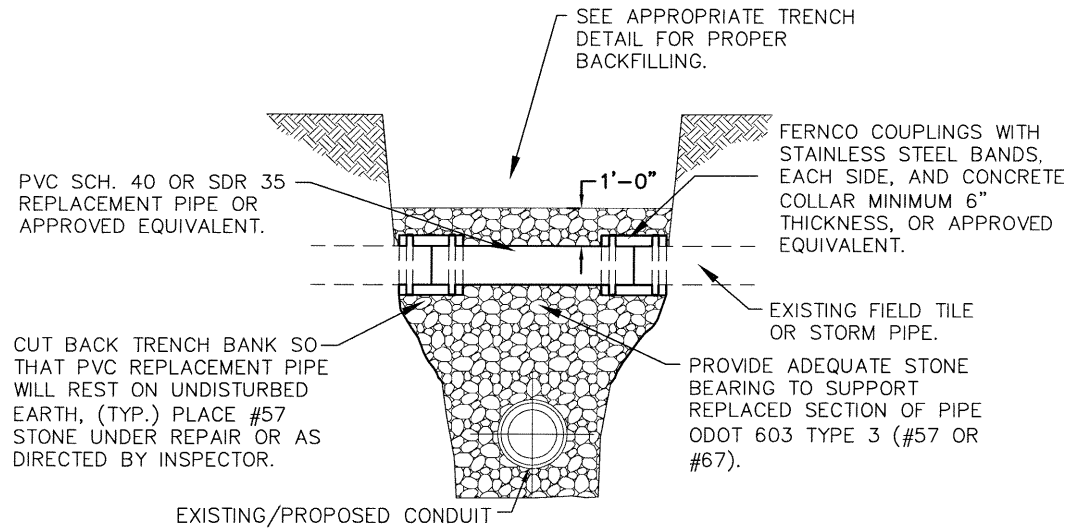

REPAIR OF EXISTING FIELD TILE OR STORM PIPE DETAIL

NOTES

CONCRETE REPAIRS OR PATCHES ARE UNACCEPTABLE.

CITY OF
PIQUA

CHOICE
ONE
ENGINEERING

REPAIR OF EXISTING FIELD TILE OR STORM PIPE DETAIL

REVISIONS:

DATE
APPROVED:
AUG. 2008

PAGE No.

600-14