

APPLICATION FOR DECK PERMIT

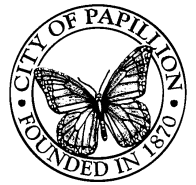

REQUIRED INFORMATION

ALL SEEN BELOW

SPECIES OF LUMBER

HEIGHT OF DECK ABOVE GRADE

ADDITIONAL DECK REQUIREMENTS ON BROCHURE

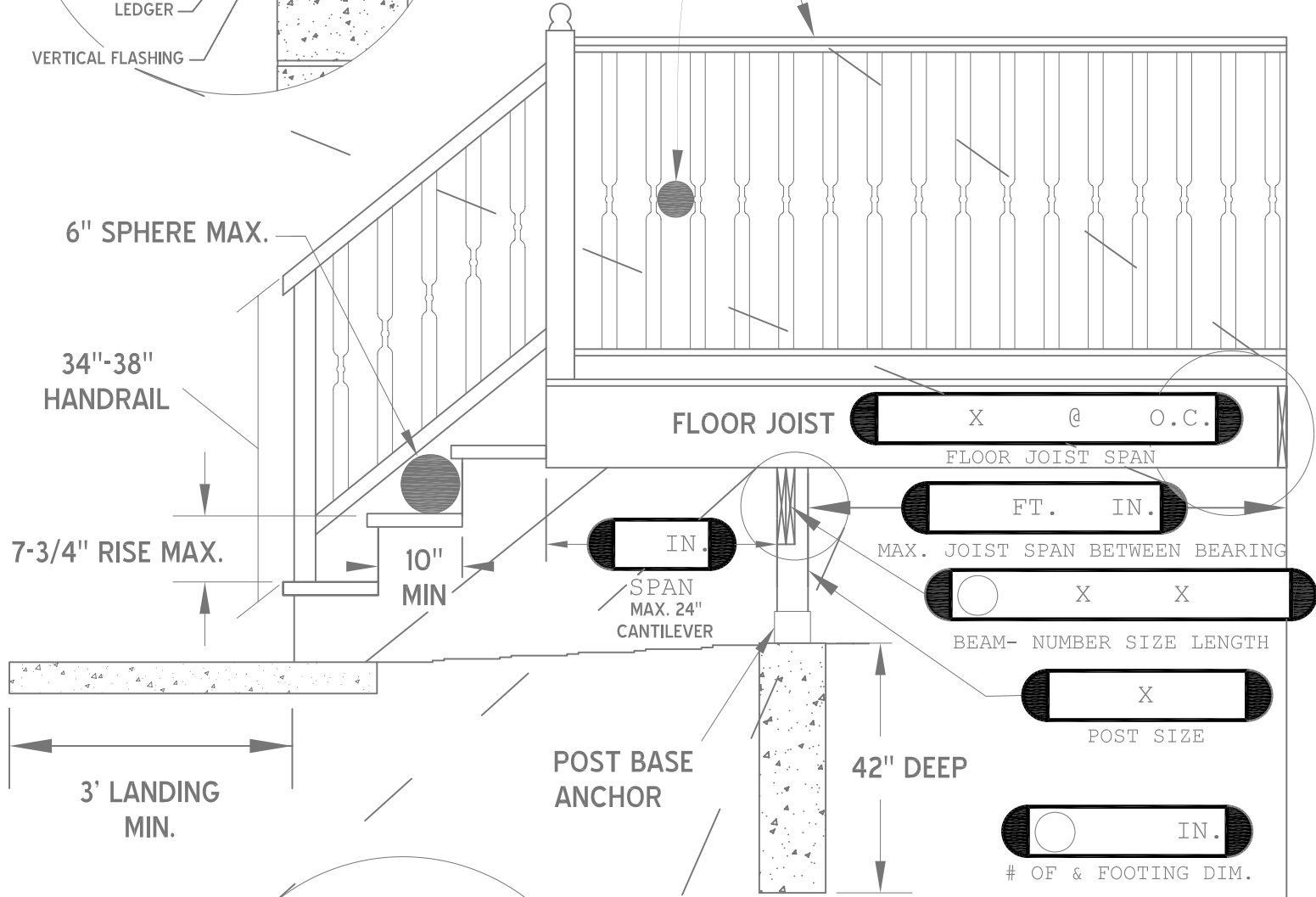
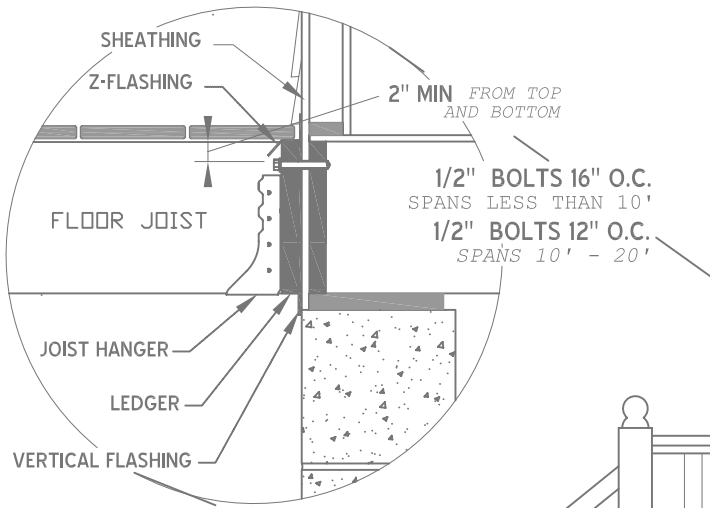

FLOOR JOIST X @ O.C.

FLOOR JOIST SPAN FT. IN.

MAX. JOIST SPAN BETWEEN BEARING FT. IN.

BEAM- NUMBER SIZE LENGTH

X

POST SIZE X

OF & FOOTING DIM. IN.

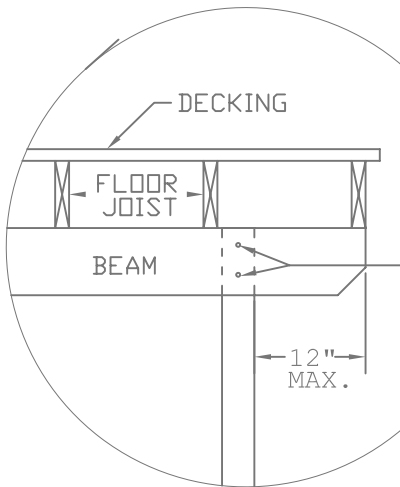

MIN. POST TO BEAM CONNECTION:
 (2) 1/2" THROUGH BOLTS OR
 (4) STAGGERED LAG SCREWS

IN.

BEAM CANTILEVER

DECK FLOOR/FOOTING PLAN

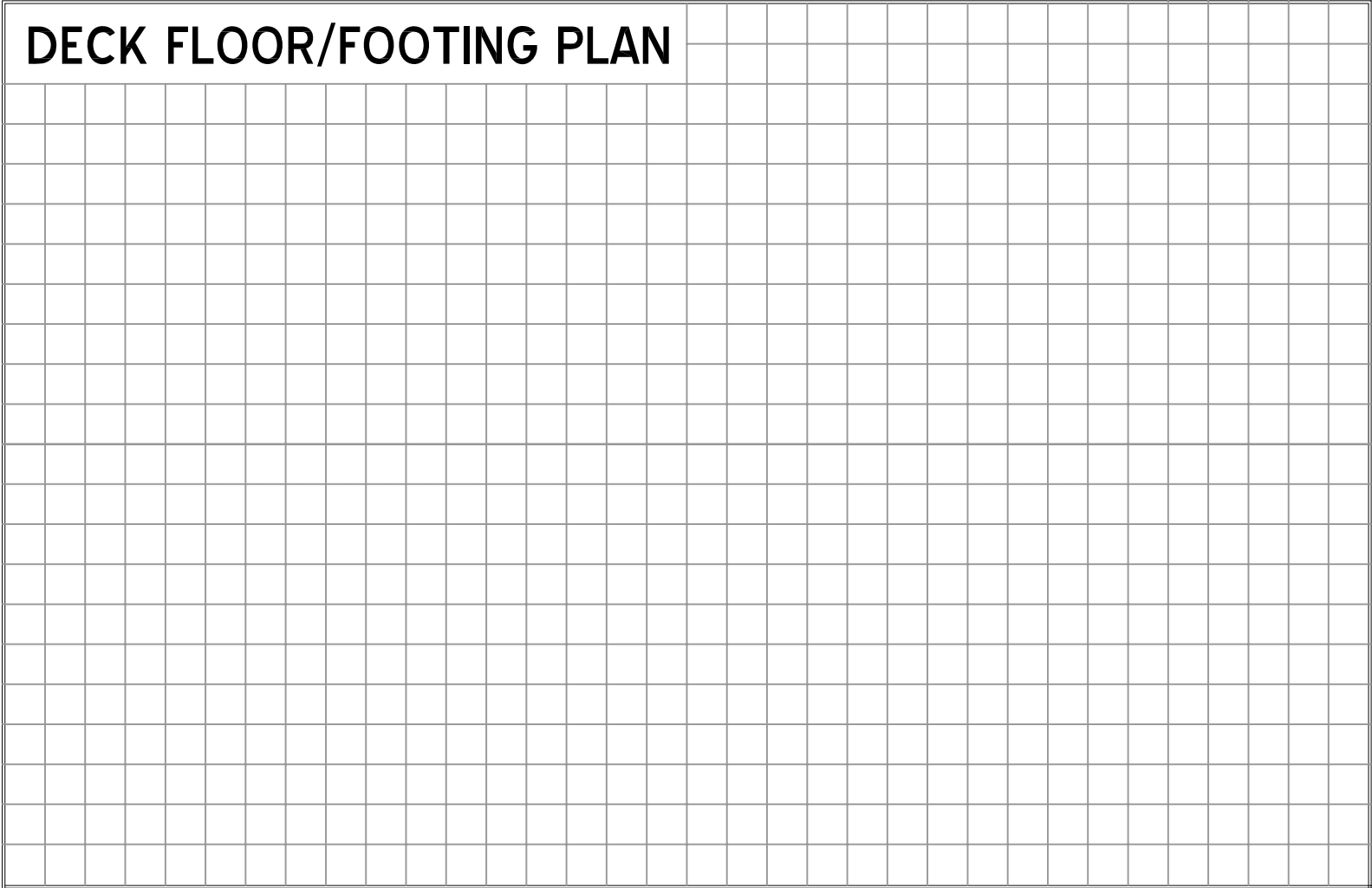

General requirements for decks:

1. Decks more than 30" above finish grade are required to have a guardrail not less than 36".
2. Stair railing, handrails, and landings are required with 3 or more risers. Handrails need to be 34"-38" measured vertically off the nosing of the treads. Handrails shall have returns.
3. Handrails cannot be less than 1-1/4", or more than 2" if circular. If not circular, the perimeter dimension will have a min of 4" and a max of 6 1/4".
4. No place in the deck's guardrail will allow the passage of a 4" sphere. Other than the triangular opening formed by the riser, tread, and bottom rail of guard shall allow a 6" sphere.
5. Deck risers can't exceed 7-3/4" and must not have more than 3/8" variance between any two risers. Stair treads must be a minimum of 10". There may not be more than 3/8" variance between tread depth.
6. Deck stairs are required to be a minimum of 36" wide. Where the stairs have two or more risers they will be served by a landing extending past the last tread nosing a min. of 36" for the width of the stairs.
7. Supporting posts must rest on top and be connected to the footing. Posts are not permitted to be buried in the ground or footing.
8. Cantilevers for beams may not exceed 12". Cantilevers for floor joist may not exceed 24".
9. Deck Footing shall be dug to a depth of 42"
10. Flashing is required to separate the deck from the house.

*** FOR ADDITIONAL DECK INFORMATION SEE BROCHURE**

CITY OF PAPILLION

122 East Third Street
Papillion, NE 68046
www.papillion.org



INSPECTION HOTLINE 402-597-2072