

ARTICLE III, Construction Codes [Adopted 01-02-2008 by Ord. No. 1536]

§ 92-15. Adoption of standards.

A. To provide certain minimum standards, provisions and requirements for safe and stable design, methods of construction and uses of materials in buildings hereafter erected, constructed, enlarged, altered, repaired, relocated and converted, the following uniform codes are hereby incorporated by reference in addition to all amended additions as though printed in full herein. Sections of these codes are modified, amended or deleted elsewhere in this article.

Two copies of the International Building Code, The International Residential Code and the International Energy Conservation Code are to be retained on file with the City Clerk.

These codes shall be in effect within the limits of the City and its two-mile jurisdictional limits.

Copies of said international codes printed in booklet or pamphlet form shall be maintained in the office of the Papillion Chief Building Official:

- (1) International Energy Conservation Code (IECC) 2006 edition.
- (2) International Plumbing Code (IPC) 2006 edition.
- (3) International Mechanical Code (IMC) 2006 edition.
- (4) International Code Council Electrical Code (administrative provisions for NEC) 2005 (latest edition) National Electrical Code (NEC).
- (5) International Fuel Gas Code (IFGC) 2006 edition.
- (6) International Existing Building Code (IEBC) 2006 edition.
- (7) International Residential Code (IRC) 2006 edition.
- (8) International Building Code (IBC) 2006 edition.

B. The 2006 International Residential Code is hereby adopted as amended, altered, modified and changed in the following respects:

- (1) Specifically adopted are:
 - (a) The International Residential Code, 2006 edition, Chapters 1-23, inclusive,
 - (b) Appendix K, "Sound Transmission", of the International Residential Code, 2006 edition.
- (2) Specifically not adopted are Appendix Chapters A, B C, D E F, G H, I, and J of the International Residential Code, 2006 edition.
- (3) The International Residential Code shall apply to the construction, alteration, enlargement, replacement or repair of detached one and two family dwellings and their accessory structures, and any new construction required as a result of moving a one- or two family dwelling.

Page 3

Section 105.2, Work exempt from permit. Revise building list items 1, 2, 5 and 7 to read as follows:

1. Playhouses and landscaping features to include terrace/retaining walls under four feet in height, trellises and other similar structures.
2. Privacy partitions to enclose private patios or decks that are not used as fences to enclose yards or located along property lines less than 8' in height.

5. Replacement paved slab-on-grade surfaces for sidewalks and driveways provided no increase in square footage is added and there is no change in grading creating additional storm drainage to adjacent properties.

7. Prefabricated swimming pools that are less than 18 inches deep installed entirely above ground.

The 2006 IRC sections below amended 08.04.2010 by Ordinance #1594

Add Section R106.2.1 Surveyor’s Certificate. A Surveyor’s Certificate is required with submission of site plan for all construction on a new or vacant lot.

Add Section R109.1.6 Termite Report. A termite report is required at time of final inspection.

Page 12

Section R202, Definitions. Change the definition of Dwelling to read: Dwelling. Any building that contains one dwelling unit used, intended, or designed to be built, used, rented, leased, let or hired out to be occupied, or that is occupied for living purposes.

Page 18

Section R202, Definitions. Add the following definition: Sleeping Room. Any room in the house that is greater than 70 sq. ft., has built-in closet space and typically could be used as a bedroom. This does not include rooms used for cooking, eating, family living or gathering and excludes bathrooms, toilet rooms, halls, storage, utility and workshop space and all unconditioned space.

Page 19

Section R202, Definitions. Change the definition of Townhouse to read: Townhouse. A single-family dwelling unit constructed in a group of two or more attached units in which each unit extends from foundation to roof and with open space on at least two sides.

Page 24

Add the following information to **Table R301.2(1)**,

GROUND SNOW LOAD	WIND SPEED (mph) ^d	SEISMIC DESIGN CATEGORY ^f	SUBJECT TO DAMAGE FROM			WINTER DESIGN TEMP ^e	ICE BARRIER UNDERLAYMENT REQUIRED ^h	FLOOD HAZARDS ^g	AIR FREEZING INDEX ⁱ	MEAN ANNUAL TEMP ^j
			Weathering ^a	Frost line depth ^b	Termit ^{e,c}					
20 ^k 30 ^l	90	A	Severe	42	M-H	-3 ^o	Yes	1971	1680	51.2 ^o

k. Slopes equal to or greater than 4 in 12. Soil bearing 1500 lbs/sq.

l. Slopes less than 4 in 12.

Page 46

Table R301.5, Minimum Uniformly Distributed Live Loads. Change the table to read: Sleeping rooms 40.

The 2006 IRC section below amended 08.04.2010 by Ordinance #1594

Section R303.3 Bathrooms. Bathrooms, water closet compartments, and other similar rooms shall be provided with a mechanical ventilation system. The minimum ventilation rate shall be 50 cfm (23.6 L/s) for intermittent ventilation or 20 cfm (9.4 L/s) for continuous ventilation. Ventilation air from the space shall be exhausted directly to the outside.

Page 48

Section R305.1, Minimum height. Add the following paragraph after exception 4: The building official shall have the authority to waive the requirements of this section where pre-existing conditions will not allow the requirements to be met.

Page 50

Section R308.4(7)(7.2), Hazardous Locations. Change 7.2 to read as follows: "Windowsill height is less than 18 inches (457 mm) above the floor."

The 2006 IRC section below amended 08.04.2010 by Ordinance #1594

Section R310.1 Emergency escape and rescue required. Add at the end of paragraph: Rooms with a closet or direct access to a bathroom shall be considered sleeping rooms.

Page 53

Section R311.4.3, Landings at doors. Change exception 1 to read: 1. Where a stairway of three or fewer risers is located on the exterior side of a door, other than the required exit door, a landing is not required for the exterior side of the door provided the door, other than an exterior storm or screen door does not swing over the stairway.

Page 53

Section R311.4.3, Landings at doors. Change exception 2 to read: 2. The exterior landing at an exterior doorway shall not be more than 7 ¾ inches (196mm) below the top of the finished floor, provided the door, other than an exterior storm or screen door does not swing over the landing.

Page 53

Section R311.4.3, Landings at doors. Change exception 3 to read: 3. The height of floors at exterior doors other than the exit door required by Section R311.4.1 shall not be more than 7 ¾ inches (196 mm) lower than the top of the finished floor.

Page 54

Section R311.5.3.3, Profile. Change to read as follows: The radius of curvature at the leading edge of the tread shall be no greater than 9/16 inch (14 mm). A nosing not less than ¾ inch (19 mm) but not more than 1 ¼ inch (32 mm) shall be provided on stairways with solid risers. The greatest nosing projection shall not exceed the smallest nosing projection by more than 3/8" (9.5 mm) between two stories, including the nosing at the level of floors and landings. Beveling of nosing shall not exceed ½ inch (12.7 mm). Risers shall be vertical or sloped from the underside of the leading edge of the tread above at an angle not more than 30 degrees (0.51 rad) from the vertical. Open risers are permitted, provided that the opening between treads does not permit the passage of a 6 ½ inch diameter (165 mm) sphere.

Page 54

Section R311.5.6.2 Continuity. Add exception 3 to read as follows:

Exceptions: 3. Handrails for stairways shall be permitted to have no more than a 4" break (102 mm) due to wall offsets and other ornamental features.

Page 54

Section R311.5.2, Headroom.

Change as follows: "The minimum headroom in all parts of the stairway shall not be less than six feet, eight inches (2032 mm) measured vertically from the sloped plane adjoining the tread nosing or from the floor surface of the landing or platform."

Add the following as a second paragraph: "The building official shall have the authority to waive the requirements of this section where pre-existing conditions will not allow the requirements to be met."

Page 55

(a) **Section R313.1.1, Alterations, Repairs and Additions.** Change as follows: "Exceptions: 1. Smoke alarms in existing areas shall not be required to be interconnected and hard wired where the alterations or repairs do not result in the removal of interior wall or ceiling finishes exposing the structure."

Page 58

Section R317.1, Two-family dwellings. Delete exception #1 in its entirety.

Page 58

Section R317.2, Townhouses. Change the exception to read as follows: Exception: A common 2-hour fire-resistance-rated wall is permitted for townhouses if such walls do not contain plumbing or mechanical equipment, ducts or vents in the cavity of the common wall. Electrical, cable, and telephone installations are permitted, but shall be installed in raceways and metallic outlet boxes. Penetrations of electrical outlet boxes shall be in accordance with Section R317.3. The fire-resistance rating of the common wall may be reduced to not less than 1-hour provided the building is equipped throughout with an automatic sprinkler system installed in accordance with NFPA 13, the common wall does not contain plumbing or mechanical equipment, ducts or vents, and electrical, cable, and telephone installations are installed in raceways and metallic outlet boxes.

Page 60

Section R318.1, Moisture control. Add an exception #4 to read as follows: Exception 4. Exterior bathroom walls.

Page 60

Section R319.1, Location required. Change location #2 to read as follows: All wood framing members, sills or plates that rest on concrete or masonry exterior walls.

Page 60

Section R319.1.1, Field treatment. Delete this section in its entirety.

Page 61

Section R319.1.4, Wood columns. Delete both exceptions and replace with: Exception: Interior columns, either exposed or enclosed within the framing cavity, provided such columns are separated from any concrete or masonry by approved wood of natural decay resistance, or approved pressure-preservative treated wood.

Page 61

Section R320.1.2, Field treatment. Delete this section in its entirety.

Page 63

Section R324.2.1, Elevation requirements. Change requirement 1 to read as follows: 1. Buildings and structures shall have the lowest floors elevated to a level 1 foot minimum above the design flood elevation.

Page 63

Section R324.2.1, Elevation requirements. Change requirement 3 to read as follows: 3. Basement floors that are below grade on all sides shall be elevated to a level 1 foot minimum above the design flood elevation.

Section 402.1, Wood Foundations. Add the following:

Exceptions:

1. Footings shall be in accordance with Section R403.
2. If stud space is used for an air plenum, the stud space shall be lined with one-quarter inch gypsum wall board or galvanized 24 gage sheet metal.

Wherever the wall is penetrated by pipes, conduits, electrical devices or other items, the opening shall be sealed tight with approved materials.

Change to read as follows:

R403.1, General. All exterior walls shall be supported on continuous concrete footings, or other approved structural systems which shall be of sufficient design to accommodate all loads according to Section R301 and to transmit the resulting loads to the soil within the limitations as determined from the character or the soil. Footings shall be supported on undisturbed natural soils or engineered fill.

R403.1.1, Minimum size. Minimum sizes for concrete and masonry footings shall be as set forth in Table R403.1 and Figure R403.1(1). The footing width, W, shall be based on the load-bearing value of the soil in accordance with Table R401.4.1. Spread footings shall be at least 8 inches (203 mm) thick. Footing projections, P, shall be at least 2 inches (51 mm) and shall not exceed the thickness of the footing. The size of footings supporting piers and columns shall be based on the tributary load and allowable soil pressure in accordance with Table R 401.4.1. Footings for wood foundations shall be in accordance with the details set forth in Section R403.3, and Figures R403.1(2) and R403.1(3).

Delete **Figure R403.1(1)** in its entirety, and replace it with Figure R403.1(1) MINIMUM FOOTING AND FOUNDATION REQUIREMENTS, as amended.

Figure R403.1(2) delete all references to gravel footings and replace with, Footings shall comply with Section R403.

Figure R403.1(3) delete all references to gravel footings and replace with, Footings shall comply with Section R403.

R403.1.4.1, Frost protection. Except where otherwise protected from frost, foundation walls, piers and other permanent supports of buildings and structures shall be protected from frost by one or more of the following methods:

1. Extended below the frost line specified in Table R301.2(1);
2. Designed and sealed by Structural Engineer.
3. Constructing in accordance with ASCE 32; or
4. Erected on solid rock.

Exceptions:

1. Protection of freestanding accessory structures with an area of 750 square feet (70 m²) or less, of light-framed construction, with an eave height of 10 feet (3048 mm) or less shall not be required.
2. Protection of freestanding accessory structures with an area of 400 square feet (37 m²) or less, of other than light-framed construction, with an eave height of 10 feet (3048 mm) or less shall not be required.
3. Decks not supported by a dwelling need not be provided with footings that extend below the frost line.

Footings shall not bear on frozen soil unless the frozen condition is permanent.

Page 73

Change to read as follows:

R403.2, Footings for wood foundations. Footings for wood foundations shall be in accordance with Figures R403.1(2) and R403.1(3).

Page 73

Delete **Section R403.3 Frost protected shallow foundations.** Add the following: All frost protected shallow footings must be designed and sealed by a Structural Engineer Licensed by the Nebraska Board of Engineers & Architects.

Page 78

Delete **Table R404.1(1)** in its entirety, and replace it with Table R404.1(1) as amended.

Delete conditions 2, 3, 4 and 5 of **Section R404.1** and replace with:

2. Floor joists and blocking shall be connected to the sill plate at the top of the wall by the prescriptive method called out in Figure 404.1.2.
3. The sill plate shall be connected to the top of the foundation wall in accordance with Table R404.1(1) All anchor bolts shall be ASTM A307. The nut on each bolt shall be torqued to a minimum of 35 pound feet.

4. Anchor bolt spacing shall be no greater than the spacing of the rebar specified in Table R404.1.1 plus additional bolts as required by Section R403.1.6.
5. The floor shall be blocked perpendicular to the floor joists as shown in Figure R404.1.2.

Page 79

Delete **Table R404.1(2)** in its entirety, and replace it with Figure R404.1(2) as amended.

Delete Section **R404.1.1** in its entirety.

Delete Section **R404.1.2** in its entirety.

Page 80

Add a footnote to **Table R404.1(3)** to read as follows:

- a. For the purposes of this chapter, use the column labeled GW, GP, SW and SP soils.

Page 81

Delete **Table R404.1.1(1)** in its entirety, and replace it with Table R404.1(1)

Page 82

Delete **Table R404.1.1(2)** in its entirety, and replace it with Table R404.1(1)

Page 83

Delete **Table R404.1.1(3)** in its entirety, and replace it with Table R404.1(1)

Page 84

Delete **Table R404.1.1(4)** in its entirety, and replace it with Table R404.1(1)

Page 85

Delete **Table R404.1.1(5)** in its entirety, and replace it with Table R404.1(1)

This table is based on a design, which would subject the foundation walls to a soil pressure that would be exerted by soil having an equivalent fluid weight of 35 pounds per cubic foot. In order to use this table the bottom of the foundation wall must be retained by a concrete slab with a minimum thickness of 3 1/2" and the top of the wall must be restrained as defined in the footnotes of this table.

TABLE R404.1(1) BASEMENT FOUNDATION WALL DESIGN

1	2	3	4	5	6
Wall Type	Distance of	Wall Thickness	Vertical Wall	Required	Required

	Wall to Ground Surface		Span	Vertical Reinforcing	Anchor Bolt Spacing
Masonry or Concrete	6" or more	8"	8' 8" or less	#5 @ 40"	5/8" @ 40"
			8' 0" or less	#5 @ 48"	5/8" @ 48"
		10"	8' 8" or less	#5 @ 48"	5/8" @ 48"
			8' 0" or less	#5 @ 56"	5/8" @ 56"
		12"	8' 8" or less	#5 @ 56"	5/8" @ 56"
			8' 0" or less	#5 @ 64"	5/8" @ 64"
	16" or more	8"	8' 8" or less	#5 @ 48"	5/8" @ 48"
			8' 0" or less	#5 @ 56"	5/8" @ 56"
		10"	8' 8" or less	#5 @ 64"	5/8" @ 64"
		12"	8' 8" or less	#5 @ 64"	5/8" @ 64"
	24" or more	8" or more	8' 8" or less	#5 @ 64"	5/8" @ 64"
	48" or more	8" or more	8' 8" or less	None required	5/8" @ 72"

1. This table applies to hollow unit masonry or to solid concrete walls.
2. This table is only applicable where the exterior grade is above the basement slab on one or more sides of the basement. The distance in column (2) is to be measured from the top of the masonry or concrete wall down to the finish grade after final grading.
3. The thicknesses given are nominal. Actual masonry thickness may be 3/8" less than nominal.
4. This table applies only to walls which span vertically between levels at which resistance to inward movement is provided by a minimum 3 1/2" thick concrete floor slab at the bottom and an anchoring system as defined in Section R404.1 and Figure R404.1.1 at the top.
5. All reinforcing steel utilized based on this table shall be grade 60 and shall be placed not more than 1 1/2" from the inside face of the wall.
6. Masonry walls must comply with Section R609.
7. Walls which do not fall within the limitations of this table, shall be designed by a registered engineer licensed in the State of Nebraska.
8. Anchor bolts shall be 5/8" diameter with a 3/16"x 2" galvanized washer and nut. Bolts shall be imbedded minimum 7" into concrete and 15" into masonry.

Page 89

Section R405.2.3 Drainage System. Add the following to first paragraph: And shall not be recirculating.

Page 103

Change to read as follows:

R502.6.2 Joist framing. Joists framing into the side of a wood girder shall be supported by approved framing anchors

Page 121

Section R506.1, General. Add the following after the first paragraph:

The maximum slump of the concrete as placed shall not exceed five inches. Exterior slabs shall be constructed with control joints having a depth of at least 1/4 of the slab thickness and joints shall be spaced at intervals of not more than 12 feet in each direction.

Page 121

Section R506.2.2 Base, Delete this section in its entirety.

Page 114

Section R506.2. Delete this section in its entirety.

Page 224

Section R613.2, Window sills. Delete this section in its entirety.

Page 231

Table R702.3.5, Minimum Thickness and Application of Gypsum Board. Change footnote (d) to read as follows. D. Three-eighths-inch-thick single-ply gypsum board shall not be used on a ceiling where a water-based textured finish is to be applied, or where it will be required to support insulation above a ceiling. On ceiling applications to receive a water-based texture material, either hand or spray applied, the gypsum board shall be applied perpendicular to framing. When applying a water-based texture material, the minimum gypsum board thickness shall be 1/2 inch.

Page 241

Section R703.7.4.2, Air Space. Change to read as follows: The veneer shall be separated from the sheathing by an air space of a minimum of a nominal 1/2 inch (13 mm) but not more than 4 1/2 inches (114 mm).

Page 268

Table R802.11 Required Strength of Truss or Rafter Connections to Resist Wind Uplift Forces

Add footnote G to read as follows:

g. Wind uplift calculations, prepared by a structural engineer, shall be provided at the time of the framing inspection, for all structures built without uplift connections as prescribed by this table.

Page 291

Section R905.2.5, Fasteners. Change to read as follows: Fasteners for asphalt shingles shall be galvanized steel, stainless steel, aluminum or copper roofing nails, minimum 12 gage [0.105 inch (3 mm)] shank with a minimum 3/8-inch (10 mm) diameter head, ASTM F 1667, or if approved by the manufacturer, corrosion-resistant staples, minimum 16 gage 15/16 inch crown width, of a length to penetrate through the roofing materials and a minimum of 3/4 inch (19 mm) into the roof sheathing.

Where the roof sheathing is less than $\frac{3}{4}$ inch (19 mm) thick, the fasteners shall penetrate through the sheathing. Fasteners shall comply with ASTM F 1667.

Page 292

Table R905.2.8.2, Valley Lining Material. In the Gage column, for Galvanized steel, delete the number 26, and replace it with 28.

Page 292

Section R905.2.8.4, Sidewall flashing. Change to read as follows: Flashing against a vertical sidewall shall be corrosion-resistant metal of minimum 28 gage.

Page 293

Section R905.3.8, Flashing. Change the first sentence to read as follows: At the juncture of roof vertical surfaces, flashing and counterflashing shall be provided in accordance with this chapter and the manufacturer's installation instructions and, where of metal, shall not be less than 0.018 inches (0.4 mm) (No. 28 galvanized sheet gage) corrosion-resistant metal.

Page 295

Section R905.7.6, Valley flashing. Change the first sentence to read as follows: Roof flashing shall be not less than No. 28 gage [(0.018 inches (0.4 mm))] corrosion-resistant sheet metal and shall extend 10 inches (254 mm) from the centerline each way for roofs having slopes less than 12 units vertical in 12 units horizontal (100-percent slope), and 7 inches (178 mm) from the centerline each way for slopes of 12 units vertical in 12 units horizontal and greater.

Page 296

Section R905.8.8, Valley flashing. Change the first section to read as follows: Roof flashing shall not be less than No. 28 gage [(0.018 inches (0.4 mm))] corrosion-resistant sheet metal and shall extend at least 11 inches (279 mm) from the centerline each way.

Page 299

Section R907.3, Re-covering versus replacement. Change condition 2 to read as follows: 2. Where the existing roof covering is wood shake, wood shingle, slate, clay, cement or asbestos-cement tile.

Page 299

Section R907.4, Roof Recovering. Delete this section in its entirety.

Page 310

Section R1006.2, Exterior air intake. Change to read as follows: The exterior air intake shall be capable of supplying all combustion air from the exterior of the dwelling or from spaces within the

dwelling ventilated with outside air such as non-mechanically ventilated crawl or attic spaces. The exterior air intake shall not be located within the garage or basement of the dwelling. The exterior air intake shall be covered with a corrosion-resistant screen of ¼-inch (6 mm) mesh.

Page 311

Delete Chapter 11 in its entirety and replace with: Compliance shall be demonstrated by meeting the requirements of the 2006 IECC applicable tables and sections.

Compliance shall be demonstrated by either:

1. Submitting a completed and signed compliance certificate using REScheck, as downloaded from the Department of Energy; or
2. Meeting the requirements of the International Energy Conservation Code for residential buildings, Type A-1.

Single family dwellings, two family dwellings and town homes with a window to wall ratio greater than 15% must conform to the State of Nebraska energy code.

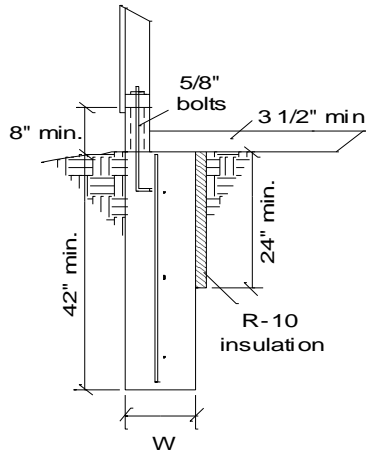

TYPICAL TRENCH FOOTING

12" min. wide, 42" min. deep. Extend foundation min. 8" above grade. Limited to supporting one floor, one roof and no masonry veneer. Vertical #4 bar @ 48" o.c., horizontal #4 bar @ 3 locations. Anchor bolts required as per chart.

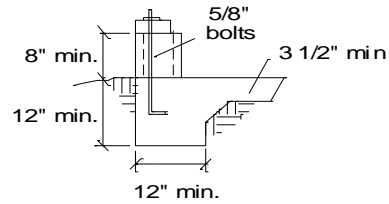

TYPICAL FLOATING FOUNDATION

Floating foundation approved for detached structures no more than 750 sq. ft. Min. 12" deep in the ground, and 12" wide at the base. Extend min. 8" above grade. Anchor bolts required as per chart.

EXCEPTIONS:

1. Detached structures less than 150 sq. ft. do not require foundations.
2. Floating foundations may use max. one course of concrete block as a curb.

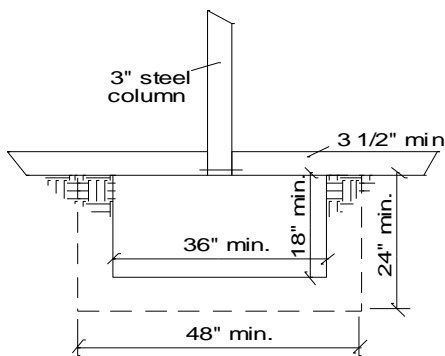

TYPICAL COLUMN FOOTING

Min. 36"x 36"x 18" for support of 1 floor and 1 ceiling/roof, and min. 48"x 48"x 24" for support of 2 floors and 1 ceiling/roof. The above column pad is limited to the support of floors and ceiling/roofs with a joist/rafter span of <= 15 ft. and beam/girder span of <= 14 ft. Min. 6"x 6"x 1/4" steel base plate is required.

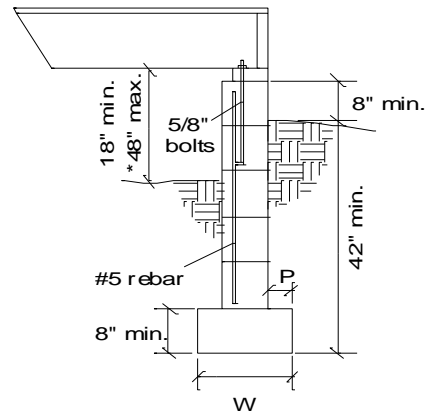

TYPICAL SPREAD FOUNDATION

2" nominal thickness treated sill plate. 5/8" bolts, min. 7" into concrete or 15" into masonry. Max. 12" from ends. 16"x 8" min. footing size. 42" min. depth for exterior walls. 8" min. depth for interior walls. Extend the foundation min. 8" above grade.

* Foundations with more than 48" of unsupported clearance shall be designed in accordance with Table R404.1(1), and Figure R404.1(2).

FIGURE R403.1(1) MINIMUM FOOTING AND FOUNDATION REQUIREMENTS (AMENDED)

GENERAL NOTES

1. Footings shall comply with Table R403.1, but shall not be less than twice the foundation wall thickness.
2. Anchor bolt spacing 6' o.c. max. or the same as the rebar spacing, whichever is less, and 12" from each end of the sill.
3. Anchor bolts shall be 5/8" diameter, with 3/16"x 2" galvanized washers. Bolts shall be imbedded min. 7" into concrete and 15" into masonry.
4. Foundations shall extend not less than 12" below the top of the floor slab.
5. Footing sizes are based on an assumed soil bearing pressure of 1,500 lbs./sq. ft. Footings on soil with a lower allowable soil pressure shall be designed in accordance with good engineering practice, and a soils engineer's recommendations.

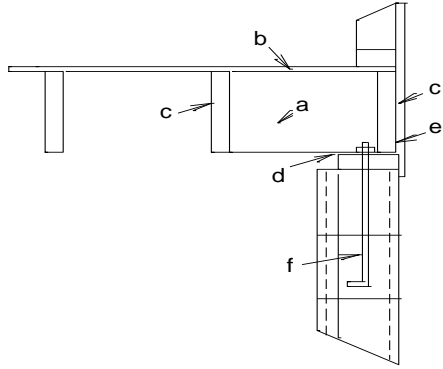

BLOCKING AT END WALL

- a. 2x solid blocking.
- b. 9- 8d nails thru subfloor into solid blocking.
- c. 4- 10d nails into each end of solid blocking.
- d. 6- 10d nails into sill plate.
- e. rim joist w/ 16d nails 12" o.c. into sill plate.
- f. anchor bolts per Table R404.1.1

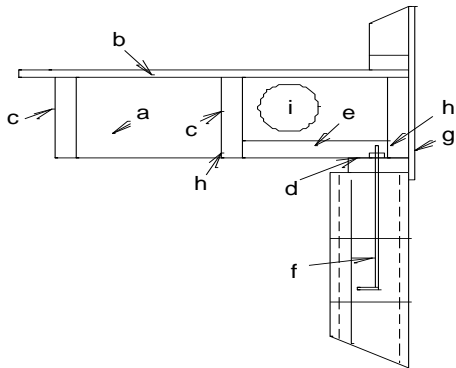

BLOCKING AT END WALL WITH DUCT

- a. 2x solid blocking.
- b. 9- 8d nails thru subfloor into solid blocking.
- c. 4- 10d nails into each end of solid blocking.
- d. 10- 10d nails thru solid blocking into sill plate.
- e. flat 2"x 10".
- f. anchor bolts per Table R404.1.1.
- g. rim joists w/ 16d nails 12" o.c. into sill plate.
- h. 2- 10d nails into each end of flat 2"x 10".
- i. duct.

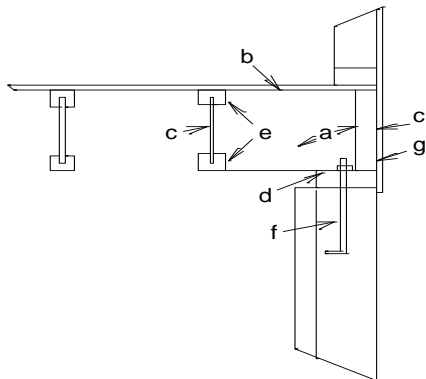

BLOCKING AT END WALL WITH "I" JOISTS

- a. 1 1/8" LSL or approved engineered rim and solid blocking material.
* (DIMENSION LUMBER NOT ALLOWED) *
- b. 9- 8d nails thru subfloor into solid blocking.
- c. 4- 10d nails into each end of solid blocking.
- d. 6- 10d nails into sill plate.
- e. 2- 10d nails toenailed into joist.
- f. anchor bolts per Table R404.1.1.
- g. rim joist w/ 16d nails 12" o.c. into sill plate.

FIGURE R404.1(2) FOUNDATION WALL TO FLOOR SYSTEM ATTACHMENT (AMENDED)

1. Where floor joists are perpendicular to the foundation wall they shall be attached to the plate in the same manner shown in the sketch **BLOCKING AT END WALL**.
2. A steel angle clip may be substituted for the 6- 10d nails connecting the joist to the sill plate. If an angle clip is used it must have a minimum load transfer capacity of 370 pounds.
3. Solid blocking must be utilized where floor joists are parallel to the foundation wall. The solid blocking shall be spaced no further apart than 1/2 the maximum anchor bolt spacing allowed in accordance with Table R404.1(1).

M1302.1, Listed and labeled. Appliances regulated by this code shall be listed and labeled for the application in which they are installed and use. The provisions of this code are not intended to prevent the installation of any material or to prohibit any design or method of construction not specifically prescribed by this code, provided that any such alternative has been approved. Alternative material, design or method of construction shall be approved where the code official finds that the proposed design is satisfactory and complies with the intent of the provisions of this code, and that the material, method, or work offered is for the purpose intended at least the equivalent of that prescribed in this code.

M1308.3, Foundations and supports. Foundations and supports for outdoor mechanical systems shall be raised at least 2 inches (51mm) above the finished grade, and shall also conform to the manufacturer's installation instructions.

M1403.1, Heat pumps. The minimum unobstructed total area of the outside and return air ducts or openings to a heat pump shall be not less than 6 square inches per 1,000 Btu/h (13208 mm²/kW) output rating or as indicated by the conditions of the listing of the heat pump. Electric heat pumps shall conform to UL 1995. INSERT

Exception: The total area of the supply air ducts and outdoor and return air ducts shall not be required to be larger than the minimum size required by the heat pump manufacturer's installations instructions.

M1403.2, Foundations and supports. Foundations and supports for outdoor unit of a heat pump shall be raised at least 2 inches (51mm) above the ground to permit free drainage of defrost water, and shall also conform to the manufacturer's installation instructions.

M1501.1, Outdoor discharge. Change to read as follows: The air removed by every mechanical exhaust system shall be discharged to the outdoors. Air shall not be exhausted into an attic, soffit, ridge vent or crawl space.

Exceptions:

1. Whole-house ventilation-type attic fans that discharge into the attic space of dwelling units having private attics shall be permitted.
2. Bathroom exhaust fans may be ducted through an exterior soffit, provided that the exhaust duct discharges through a soffit vent to the exterior.

M1502.2, Duct termination. Exhaust ducts shall terminate on the outside of the building. Exhaust duct terminations shall be in accordance with the dryer manufacturer's installation instructions.

Exhaust duct terminations shall be equipment with a backdraft damper. Screens shall not be installed at the duct termination.

M1502.5 Duct construction. Add the following to the first paragraph: All concealed pipe must be solid pipe, no flex pipe is allowed in concealed areas.

M1502.6, Duct length. The maximum length of a clothes dryer exhaust duct shall not exceed 25 feet (7620mm) from the dryer location to the wall or roof termination. The maximum length of the duct shall be reduced 2.5 feet (762mm) for each 45-degree (0.8 rad) bend and 5 feet (1524 mm) for each 90-degree (1.6 rad) bend. The maximum length of the exhaust duct does not include the transition duct.

Exceptions:

1. Where the make and model of the clothes dryer to be installed is known and the manufacturer' installation instructions for the dryer are provided to the building official, the maximum length of the exhaust duct, including any transition duct, shall be permitted to be in accordance with the dryer manufacturer's installation instructions.
2. Where large-radius 45-degree (0.8 rad) and 90-degree (1.6 rad) bends are installed, determination of the equivalent length of clothes dryer exhaust duct for each bend by engineering calculation in accordance with the ASHRAE Fundamentals Handbook shall be required.
3. The maximum length of an exhaust duct may be increased by use of a boost fan listed for clothes dryer exhaust. The boost fan and clothes dryer must be interlocked to prevent clothes dryer operation if the boost fan is not in operation.

Page 351

M1902.2, Installation: Sauna heaters shall be installed in accordance with the manufacturer's installation instructions, Nebraska Boiler Act, ASME Section 4, and the authority having jurisdiction

Page 353

M2001.1, Installation: In addition to the requirements of this code, the installation of boilers shall conform to the Nebraska Boiler Act, ASME Section 4, the authority having jurisdiction and the manufacturer's installation instructions. The manufacturer's rating data, the nameplate and operating instructions of a permanent type shall be attached to the boilers. Boilers shall have all controls set, adjusted and tested by the installer. A complete control diagram together with complete boiler operation instructions shall be furnished by the installer. Solid-and liquid-fuel-burning boilers shall be provided with combustion air as required by Chapter 17.

M2001.2, Clearance: Boilers shall be installed in accordance with their listing and label, Nebraska Boiler Act, and the authority having jurisdiction.

M2001.3, Valves. Every boiler or modular boiler shall have a shutoff valve in the supply and return piping. For multiple boiler or multiple modular boiler installations, each boiler or modular boiler shall have individual shutoff valves in the supply and return piping.

M2002.1, Safety controls. Electrical and mechanical operating and safety controls for boilers shall be listed and labeled for the purpose and condition of their use and operation.

M2002.4, Pressure-relief valve. Boilers shall be equipped with pressure relief valves with minimum rated capacities for the equipment served. Pressure-relief valves shall be set at no greater than the maximum rating of the boiler. Discharge shall be piped to drains by gravity to within 3 inches (76mm) of the floor or to an approved plumbing fixture.

M2002.5, Boiler low water cutoff. All steam and hot water boilers shall be protected with a low-water cutoff controls. The low-water cutoff shall automatically stop the combustion operation of the appliance when the water level drops below the lowest safe water level as established by the manufacturer.

M2005.1, General: Water heaters shall be installed in accordance with the manufacturer's installation instructions and the requirements of this code. Water heaters with inputs of 200,000 BTU's and greater must comply with the Nebraska Boiler Act and the authority having jurisdiction. Water heaters installed in an attic shall conform to requirements in Chapter 24. Domestic electric water heaters shall conform to UL 174 or UL1453, and NFPA 70. Commercial electric water heaters shall conform to UL1453 and NFPA 70. Oiled-fired water heaters shall conform to UL 732 and NFPA 31.

Page 354

M2005.3, Electric water heaters. Electric water heaters shall also be installed in accordance with the applicable provisions of National Electrical Code (NFPA 70).

M2006.1, General: Pool and spa heaters shall be constructed and installed in accordance with the manufacturer's installation instructions, ASME Section 4, the Nebraska Boiler Act, and the authority having jurisdiction. Oil-fired pool heaters shall be tested in accordance with UL 726 and NFPA 31. Electric pool and spa heaters shall conform to UL1261, and NFPA 70.

M2006.2, Clearances: In no case shall the clearances interfere with combustion air, draft hood or flue terminal relief, or accessibility for servicing, or as required by the Nebraska Boiler Act, and the authority having jurisdiction.

M2006.3, Pressure and Temperature-limiting devices: Pool heaters shall have temperature limiting controls and pressure relief valves.

Page 355

M2101.1, General: Hydronic piping shall conform to Table M2101.1 as amended by this section. Approved piping, valves, fittings and connections shall be installed in accordance with the installations instructions. Pipe and fittings shall be rated for use at the operating temperature and pressure of the hydronic system. Chlorinated poly (vinyl chloride) (CPVC) pipe, tubing and fittings,

Cross-linked polyethylene (PEX) pipe, tubing and fittings, Cross-linked polyethylene/aluminum/cross-linked polyethylene (PEX-AL-PEX) pipe, tubing and fittings, Polybutylene (PB) pipe, tubing and fittings, Polyethylene (PE) pipe, tubing and fittings and Polypropylene (PP) pipe, tubing and fittings will not be permitted for above ground use in a hydronic heating or cooling system. Used pipe, fittings, valves or other materials shall be free of foreign materials

M2101.2, System drain down. Hydronic piping systems shall be installed to permit draining of the system. When the system drains to the plumbing drainage system, the installation shall conform to the requirements of Chapter 25 through 32 of this code.

M2101.3, Protection of potable water. The potable water system shall be protected from backflow in accordance with the provisions listed in Section P2902.

M2101.10, Tests: Hydronic piping shall be tested hydrostatically at a pressure of not less than 100 pounds per square inch (psi) (690kPa) for a duration of not less than 30 minutes.

M2103.4 and M2104.3, Termination. (Insert) Final termination of all embedded piping systems are required to terminate to listed and labeled equipment or to a piping manifold. The maximum length from piping system entering the structure to equipment or manifold is 48 inches (1219mm).

Page 357

M2105.1, Testing: The assembled loop system shall be pressure tested with water at 100psi (690kPa) for 30 minutes with no observed leaks before connection (header) trenches are backfilled.

Page 393

Section G2420.5 (409.5) Equipment shutoff valve. Amended to read as follows: Each appliance shall be provided with two shutoff valves separate from the appliance. One shutoff valve shall be located in the same room as the appliance, not further than 6 feet (1829 mm) from the appliance, and shall be installed upstream from the union, connector or quick disconnect device it serves. The other shutoff valve shall be located at the main house manifold. Such shutoff valves shall be provided with access.